

# Pololu Wixel User's Guide

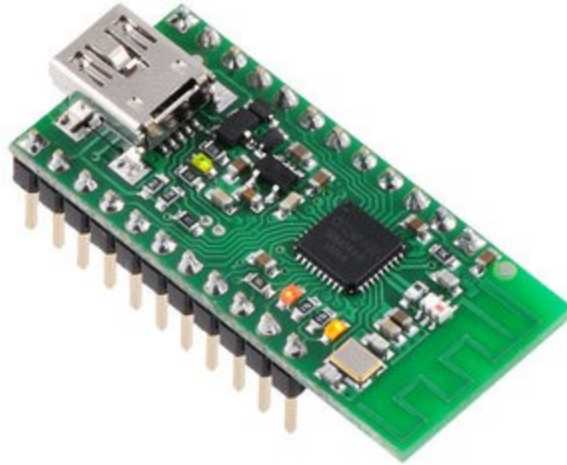

1. Overview . . . . .	3
1.a. Module Pinout and Components . . . . .	4
1.b. Supported Operating Systems . . . . .	7
1.c. Government Regulations for Radio Devices . . . . .	7
2. Contacting Pololu . . . . .	8
3. Getting Started . . . . .	9
3.a. Installing Windows Drivers and Software . . . . .	9
3.b. Installing Linux Drivers and Software . . . . .	14
3.c. Installing Mac OS X Drivers and Software . . . . .	15
3.d. Loading an Example App . . . . .	16
4. Configuring Your Wixels . . . . .	20
5. Connecting Your Wixels . . . . .	23
5.a. Connecting Power . . . . .	23
5.b. Connecting a Microcontroller via TTL Serial . . . . .	24
5.c. Connecting Buttons and Starting the Bootloader . . . . .	25
6. Using a Virtual COM Port . . . . .	28
6.a. Determining the Port Name . . . . .	28
6.b. Using a Terminal Program . . . . .	28
6.c. Writing PC Software to Use a Serial Port . . . . .	29
7. Ensuring a Good Radio Signal . . . . .	30
8. Schematic Diagram . . . . .	31
9. Wixel Apps . . . . .	32
9.a. Example App: Blink LED . . . . .	32
9.b. Wireless Serial App . . . . .	32
9.c. USB-to-Serial App . . . . .	37
9.d. Serial ASCII-to-Binary App . . . . .	38
9.e. Serial-to-I <sup>2</sup> C App . . . . .	40
9.f. I/O Repeater App . . . . .	44
9.g. Joystick App . . . . .	46
9.h. Wireless Tilt Mouse App . . . . .	49
9.i. ShiftBrite App . . . . .	51
10. Writing Your Own Wixel App . . . . .	54
10.a. Getting Started in Windows . . . . .	54
10.b. Compiling an Example App . . . . .	54
10.c. Using the Eclipse IDE . . . . .	56
10.d. Sharing Your App with the Wixel Community . . . . .	59
10.e. USB Configurations Recognized by the Wixel Configuration Software . . . . .	61
10.f. Wixel App File Format . . . . .	61
11. The Wixel USB Bootloader . . . . .	63
11.a. Bootloader Protocol . . . . .	64

## 1. Overview

The Pololu Wixel is a general-purpose programmable module featuring a 2.4 GHz radio and USB. The Wixel is based around the **CC2511F32** [<http://www.ti.com/product/CC2511>] microcontroller from Texas Instruments, which has an integrated radio transceiver, 32 KB of flash memory, 4 KB of RAM, and a full-speed USB interface. A total of 15 general-purpose I/O lines are available, including 6 analog inputs, and the 0.1" pin spacing makes the Wixel easy to use with **breadboards** [<https://www.pololu.com/category/28/solderless-breadboards>] and perfboards.

We provide free, open-source apps for the Wixel that you can load and configure with its built-in USB bootloader, turning it into whatever you need for your current project. Simply download a different app to reuse the Wixel in your next project.

Our **Wireless Serial app** turns a pair of Wixels into a wireless USB/TTL serial link for communication between two microcontrollers or between a PC and a microcontroller. This can be used, for example, for communication between two robots or to remotely monitor a robot from a computer. A special version of this app is designed for use with our **Wixel shield for Arduino** [<https://www.pololu.com/product/2500>], which makes it easy to add wireless capabilities (including wireless programmability) to an **Arduino** [<https://www.pololu.com/product/2191>] or Arduino clone. Using an RF bit rate of 350 kbps, the serial app is capable of transmitting or receiving up to 10 KB of data per second and can reach a range of approximately 50 feet (under typical conditions indoors). Multiple serial links can be used simultaneously on different channels. Detailed information about the wireless serial app is available in **Section 9.b**.

Our **USB-to-Serial app** turns a single Wixel into a USB-to-TTL serial adapter that is capable of baud rates as high as 350,000 bps and supports four serial control signals. This app does not use the radio. Detailed information about this app is available in **Section 9.c**.

Our **I/O Repeater app** allows you to wirelessly extend the reach of your microcontroller's I/O lines up to 50 feet using two or more Wixels. Detailed information about this app is available in **Section 9.f**.

We plan to release additional apps in the future for wireless AVR programming, wireless sensing, and more. You can also write your own apps using the open-source Wixel SDK (see **Section 10**) and share them with the community.

### Included Hardware

The Wixel is available in two versions:

The **Partial Kit version** [<https://www.pololu.com/product/1337>] comes with a 25×1 **straight 0.1" male header strip** [<https://www.pololu.com/product/965>]. This version is ideal for compact installations and allows flexibility in choice of connectors.

The **Assembled version** [<https://www.pololu.com/product/1336>] comes with its header pins soldered in, so it is ready to be connected to your project with no soldering required.



**Wixel programmable USB wireless module.**

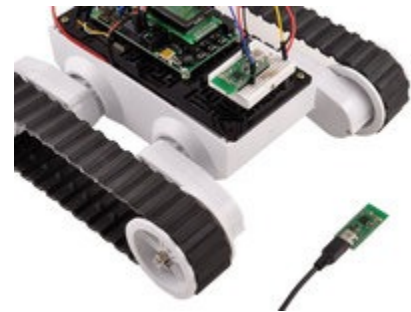

**Wixel programmable USB wireless module enabling wireless communication between a PC and robot.**

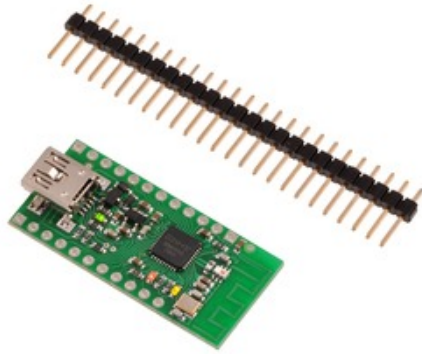

Wixel programmable USB wireless module (without header pins installed).



Wixel programmable USB wireless module (fully assembled).

1.a. Module Pinout and Components

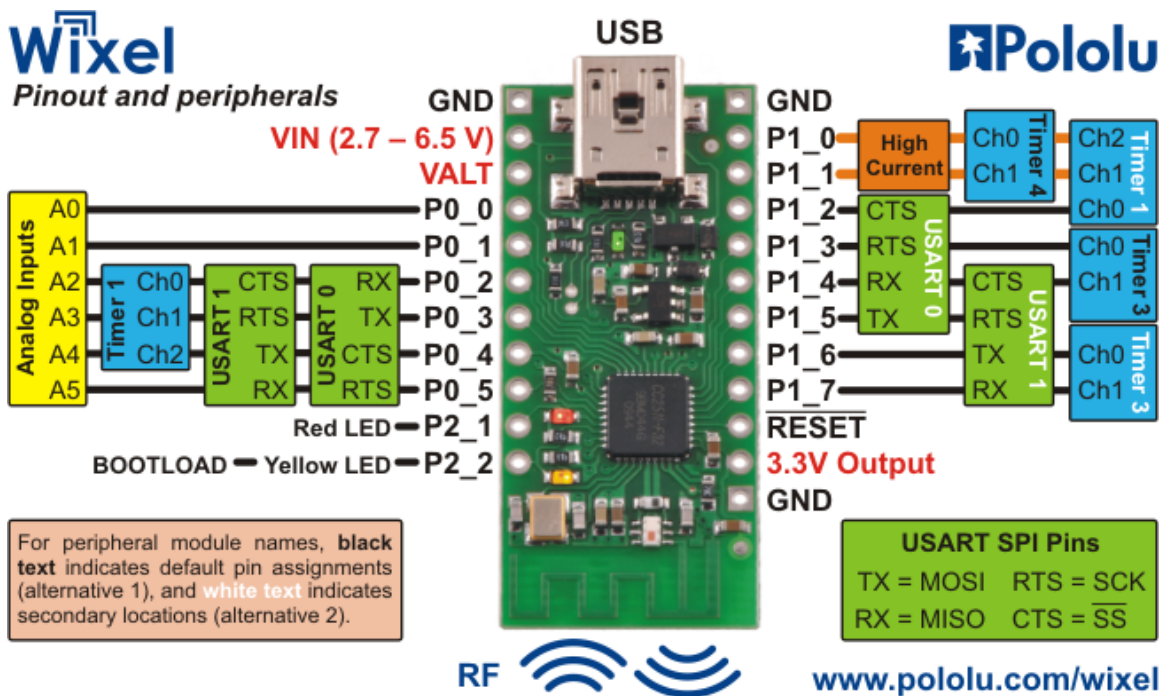

The Wixel can connect to a computer's USB port via a **USB A to Mini-B cable** [<https://www.pololu.com/product/130>] or a **USB A to Mini-B adapter** [<https://www.pololu.com/product/1126>] (not included). The USB connection is used to configure the Wixel and also to transmit and receive data. The USB connection can also provide power to the Wixel.

On the side of the board opposite the USB connector, the Wixel has a 2.4 GHz PCB trace antenna. This antenna, along with the other RF circuitry, forms a radio that allows the Wixel to send and receive data packets in the 2.4 GHz band. The Wixel is based on the CC2511F32 microcontroller from Texas Instruments, which makes it compatible with the CC2500 transceiver, the CC2510Fx family, and the CC2511Fx family of chips from Texas Instruments. The Wixel's radio is not compatible with Wi-Fi, Zigbee, or Bluetooth. The antenna is a "meandered Inverted F" design that is described in Texas Instrument's application note **AN043** [<http://focus.ti.com/lit/an/swra117d/swra117d.pdf>].

The three **GND** pins are all connected and are at 0 V by definition. When connecting the Wixel to other electronic systems, you should make sure that the Wixel's GND is connected to the other system's GND unless you are doing something very advanced.

The Wixel can be powered from **VIN** pin. Simply connect a 2.7–6.5 V power source between VIN and GND, with the positive terminal going to VIN. It is OK to connect VIN and USB at the same time. See **Section 5.a** for more information about powering your Wixels.

The **VALT** pin is connected to three things: the 5V USB bus power from the USB port (through a diode), VIN (through a diode), and to the input of the Wixel's on-board 3.3 V regulator. The connection to 5V is switched off when a power supply is connected to VIN. Most people will not need to use the VALT pin: see **Section 5.a** for example uses.

The pin labeled **3V3** on the board (**3.3V Output** in the diagram above) is connected to the output of the Wixel's 3.3V regulator. This power source can be used to power other low-current peripherals in your system. With an input voltage of 5 V (either from USB, VIN, or VALT), this output can provide up to 150 mA of current. At higher input voltages, this output can provide up to 100 mA.

The pin labeled **RST** on the board (**RESET** in the diagram above) is the reset line of the microcontroller. This pin can be driven low to perform a hard reset of the Wixel's microcontroller. This should not be necessary for typical users, but it can be useful while you are developing a Wixel application (see **Section 5.c**). This pin is internally pulled high to 3.3 V, so it is okay to leave it unconnected. If you do wire something to this pin, the CC2511F32 datasheet recommends adding an external RC filter with values of 1 nF and 2.7 kΩ close to the pin in order to avoid unintended reset of the microcontroller.

The Wixel has 15 free I/O lines whose behavior depends on the application that is loaded onto the Wixel. Specifically, these are all of the pins on Port 0 (P0\_0 through P0\_5), all of the pins on Port 1 (P1\_0 through P1\_7), and P2\_1. The **P2\_1** pin is tied to the red LED but the other 14 free I/O lines are only connected to the microcontroller. The **P2\_2** line is also accessible, but it is tied to the yellow LED and is used to get the Wixel into bootloader mode (see **Section 5.c**).

The amount of current that can be supplied by the CC2511F32's I/O pins is not well-documented by the manufacturer. According to **this forum post by a TI Employee** [[http://e2e.ti.com/support/low\\_power\\_rf/f/155/p/31555/319919.aspx](http://e2e.ti.com/support/low_power_rf/f/155/p/31555/319919.aspx)], regular I/O pins are designed to be able to source 4 mA while **P1\_0** and **P1\_1** are designed for 20 mA.

**Caution:** The Wixel's I/O lines are **not** 5V tolerant. You must use level-shifters, diodes, or voltage dividers to connect the Wixel to outputs from 5V systems. Our **bidirectional logic level shifter** [<https://www.pololu.com/product/2595>] works well for this.

The CC2511F32 has several peripherals that are available to be used in Wixel applications:

- 2 USARTs which can perform asynchronous serial or SPI communication
- 3 timers that are capable of PWM output as shown above, plus 1 more internal timer
- 6 analog input-capable pins, connected to a 7–12 bit ADC

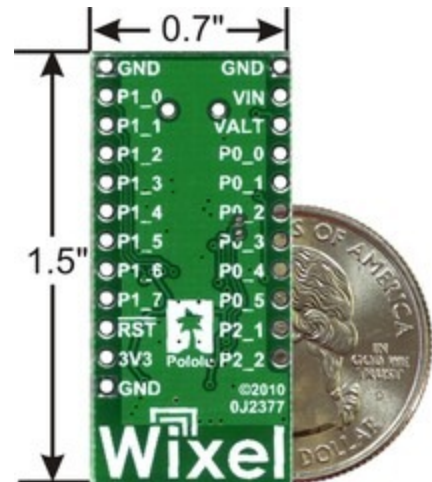

**Wixel programmable USB wireless module, bottom view with US quarter for size reference.**

Different Wixel applications may use different sets of these peripherals. Consult the application documentation for details on the behavior of the I/O lines.



The pinout and peripheral diagram at the top of this section is also available as a **printable pdf** [[https://www.pololu.com/file/download/wixel\\_pinout.pdf?file\\_id=0J462](https://www.pololu.com/file/download/wixel_pinout.pdf?file_id=0J462)] (145k pdf).

The Wixel has three indicator LEDs:

### Green USB LED

The green LED is powered from USB, so it can only be turned on when USB cable is connected and supplying power to the Wixel.

While the Wixel is in bootloader mode (i.e. the app is stopped), this LED is used to indicate the USB status of the device. When the Wixel USB Bootloader connects to USB, the green LED starts blinking slowly. The blinking continues until the bootloader receives a particular message from the computer indicating that the Wixel USB Bootloader drivers are installed correctly (see **Section 3.a** for driver installation instructions). After the bootloader gets this message, the green LED will do a double-blinking pattern. The green LED also turns off during USB Suspend Mode, which happens when the computer goes to sleep or shuts down the USB port for any other reason.

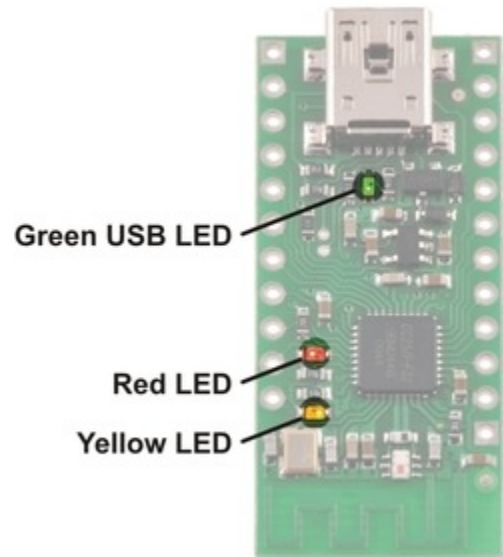

**Wixel indicator LEDs.**

While the Wixel is running its app, the behavior of the LED depends on the app. The standard apps provided by Pololu all behave as follows: When the app connects to USB, the green LED starts blinking slowly. The blinking continues until the app receives a particular message from the computer indicating that the app's drivers are installed correctly. After the app gets this message, the green LED turns solidly on. The green LED also turns off during USB Suspend Mode, which happens when the computer goes to sleep or shuts down the USB port for any other reason.

### Red LED

While the Wixel is in bootloader mode (i.e. the app is stopped), this LED indicates whether there is an application on the Wixel. If there is no application, the red LED will be on. Otherwise, it will be off. By default, the Wixel does not have an application on it, so this LED will be on the first time you power your Wixel.

The **P2\_1** pin is connected to the red LED, so this line will go high when the red LED is on and otherwise be pulled low.

While the Wixel is running its app, the behavior of this LED depends on the app. See the documentation of your particular app for more details.

### Yellow LED

While the Wixel is in bootloader mode (i.e. the app is stopped), this LED turns solidly on and flickers whenever the bootloader receives a command from Wixel software on the computer. The Wixel Configuration Utility queries the state of the bootloader once per second, so if the Wixel Configuration Utility is open then the LED will flicker once per second. While the Wixel is being programmed, the yellow LED will constantly flicker.

The **P2\_2** pin is connected to the yellow LED, so this line will go high when the yellow LED is on and otherwise be pulled low.

While the Wixel is running its app, the behavior of this LED depends on the app. See the documentation of your particular app for more details.

### 1.b. Supported Operating Systems

The **Wixel USB drivers and configuration software** currently work under Windows 8, Windows 7, Windows Vista, Microsoft Windows XP (SP 3), Linux, and Mac OS X.

Any **Wixel app** that implements a single USB virtual COM port will work on Linux or Mac OS X with no special driver installation required. Any **Wixel app** that implements a Human Interface Device (HID) will work on Windows, Linux, or Mac OS X with no special driver installation required.



**Mac OS X compatibility:** we have confirmed that the Wixel works on Mac OS X 10.7 and we can assist with advanced technical issues, but most of our tech support staff does not use Macs, so basic support for Mac OS X is limited.

### 1.c. Government Regulations for Radio Devices

**Warning about radio regulations:** The Wixel has not been tested or certified for conformance with any radio regulations, and the Wixel is shipped with only a bootloader that does not use the radio. The 2.4 GHz band is relatively unrestricted in many parts of the world, but it is your responsibility to comply with your local regulations if you program your Wixel to use its wireless capabilities.

The Wixel is a multi-purpose development platform, not a finished product, and it is not certified by the FCC or any other government agency. It is your responsibility to follow local regulations and use good engineering practices when developing, installing, and configuring apps for your Wixel. The Wixel has a low-power radio and uses the reference PCB antenna suggested by TI, so we expect typical applications developed for the Wixel to comply with FCC rules, but the Wixel is not intended for integration into other products. If you are contemplating adding Wixel-like features to your product, we recommend that you integrate the CC2511 IC directly using documentation from TI; any software developed for the Wixel should work on any other CC2511-based platform. For more information on the requirements for operating a 2.4 GHz device, see **TI Application Note 032: SRD regulations for license-free transceiver operation in the 2.4 GHz band** [<http://focus.ti.com/lit/an/swra060/swra060.pdf>].

## 2. Contacting Pololu

We would be delighted to hear from you about any of your projects and about your experience with the Wixel. You can **contact us** [<https://www.pololu.com/contact>] directly or post on our **forum** [<http://forum.pololu.com/>]. Tell us what we did well, what we could improve, what you would like to see in the future, or anything else you would like to say!



**Wixel programmable USB wireless module with USB cabled connected.**



## 3. Getting Started

### 3.a. Installing Windows Drivers and Software

Before you connect a Wixel to a computer running Microsoft Windows, you should install the drivers:

1. Download the **Wixel Windows Drivers and Software** [[https://www.pololu.com/file/download/wixel-windows-121129.zip?file\\_id=0J448](https://www.pololu.com/file/download/wixel-windows-121129.zip?file_id=0J448)] (12MB zip)
2. Open the ZIP archive and run *setup.exe*. The installer will guide you through the steps required to install the Wixel Configuration Utility, the Wixel command-line utility (WixelCmd), and the Wixel drivers on your computer. If the installer fails when run directly from the ZIP file, extract the contents of the ZIP file to a temporary directory on your computer, right click *setup.exe*, and select “Run as Administrator”.
3. During the installation, Windows will ask you if you want to install the drivers. Click “Install” (Windows 8, 7, and Vista) or “Continue Anyway” (Windows XP).

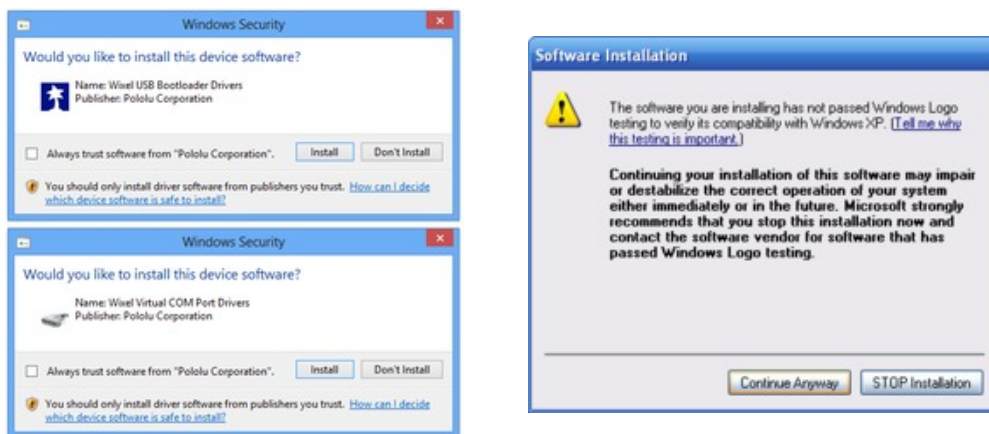

4. After the installation is finished, your start menu should have a shortcut to the *Wixel Configuration Utility* (in the *Pololu* folder). This is a Windows application that allows you to load apps onto your Wixel. There will also be a command-line utility called *WixelCmd* which you can run at a Command Prompt.

**Windows 8, Windows 7, and Windows Vista users:** Your computer should now automatically install the necessary drivers when you connect a Wixel. No further action from you is required.

**Windows XP users:** Follow steps 5–9 for each new Wixel you connect to your computer. You will also have to follow these steps again the first time you run an actual Wixel app on the Wixel.

5. Connect the device to your computer's USB port.
6. When the “Found New Hardware Wizard” is displayed, select “No, not this time” and click “Next”.



7. On the second screen of the “Found New Hardware Wizard”, select “Install the software automatically” and click “Next”.

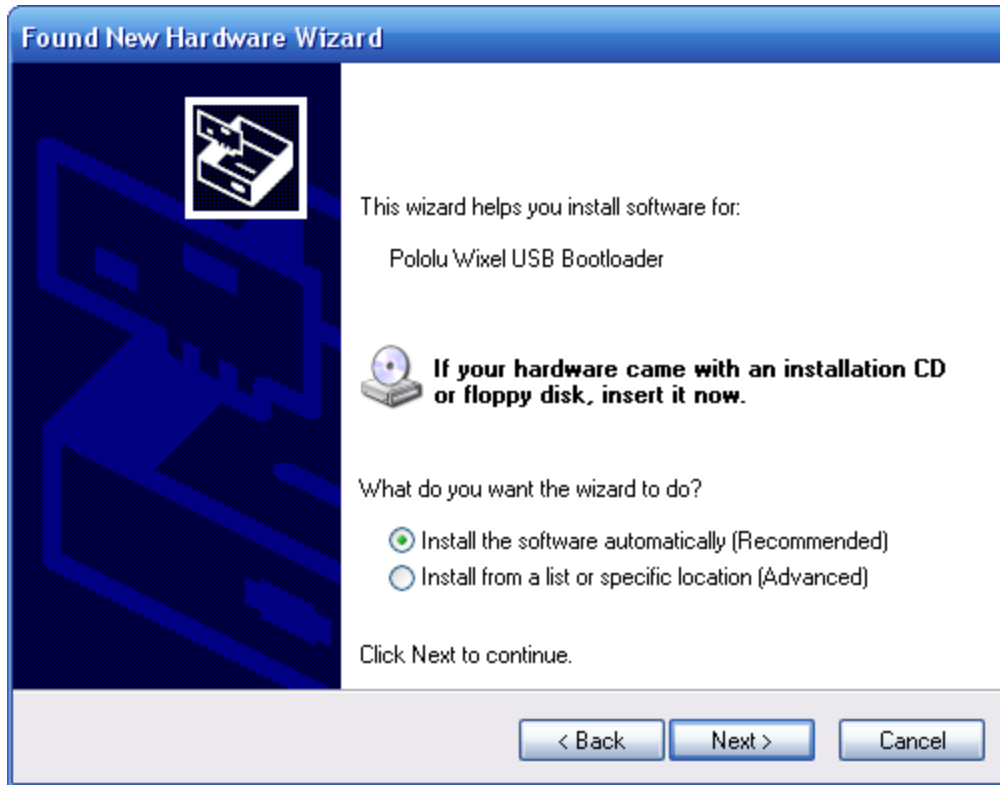

8. Windows XP will warn you again that the driver has not been tested by Microsoft and recommend that you stop the installation. Click “Continue Anyway”.

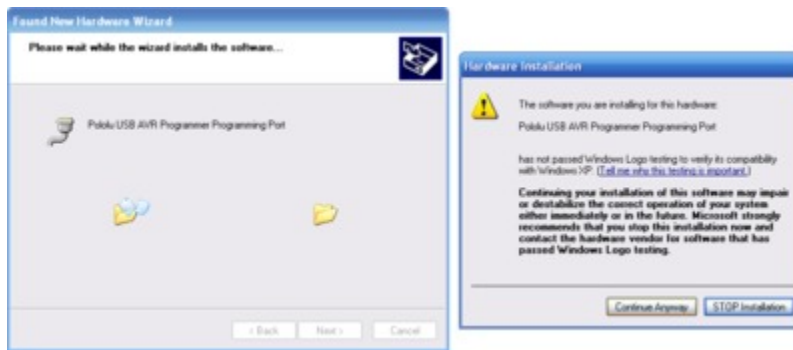

9. When you have finished the “Found New Hardware Wizard”, click “Finish”.

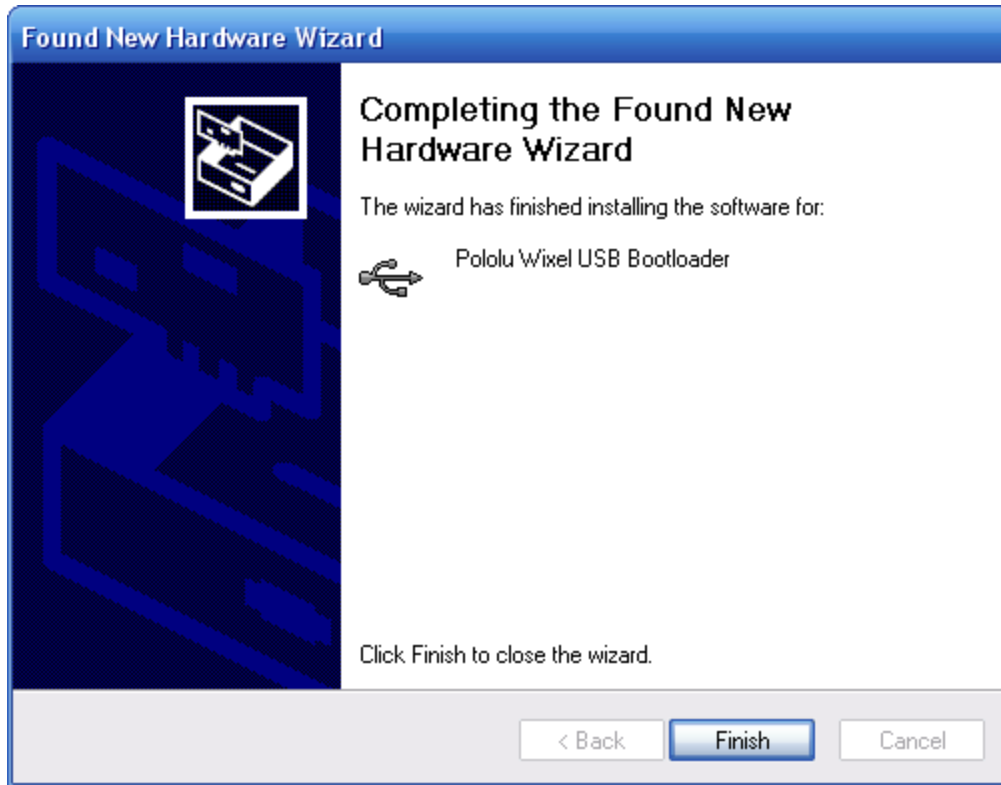

After installing the drivers, if you go to your computer’s Device Manager and expand the “Pololu USB Devices” list, you should see an entry for the Pololu Wixel USB Bootloader.

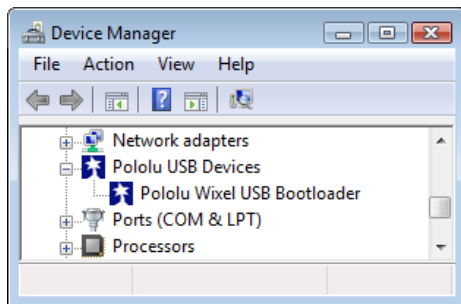

**Windows Vista or Windows 7 Device Manager showing a Wixel in bootloader mode.**



**Windows XP Device Manager showing a Wixel in bootloader mode.**

If you see the “Pololu Wixel USB Bootloader” entry in your device manager, it means that your Wixel is in bootloader mode. Your Wixel should go into bootloader mode when you first plug it into USB, because there is no app on the Wixel by default. Once you have loaded an app onto the Wixel using the Wixel Configuration Utility, and the app is running, then you will **not** see the Pololu Wixel USB Bootloader entry in your Device Manager. The entry you see in the Device Manager will depend on the application that is loaded on the Wixel. Some apps might not enable the USB interface, in which case you will see no entry for the Wixel in the Device Manager. However, typical Wixel Apps will appear in your Device Manager as a single Virtual COM port (with product ID 0x2200) in the “Ports (COM & LPT)” list as shown below:

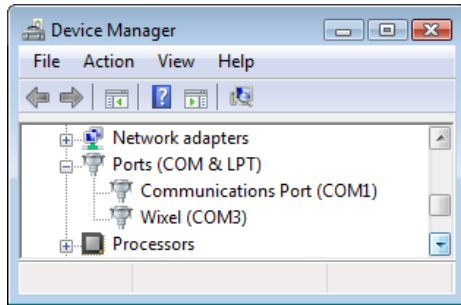

**Windows Vista or Windows 7 Device Manager showing a Wixel that is running an app with a virtual COM port.**

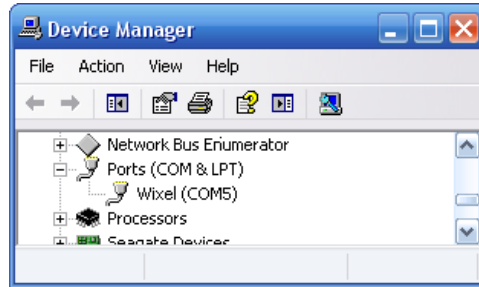

**Windows XP Device Manager showing a Wixel that is running an app with a virtual COM port.**

In parentheses, you will see the name of the port (for example, COM5 or COM6). Some software will not allow connection to higher COM port numbers. If you need to change the COM port number assigned to a Wixel, you can do so using the Device Manager. Bring up the properties dialog for the COM port and click the “Advanced...” button in the “Port Settings” tab. From this dialog you can change the COM port assigned to your device. Windows will remember which COM port was assigned to which Wixel using the built-in serial number of the Wixel; a given Wixel will always get assigned to the same COM port regardless of which USB port it is plugged into.

### 3.b. Installing Linux Drivers and Software

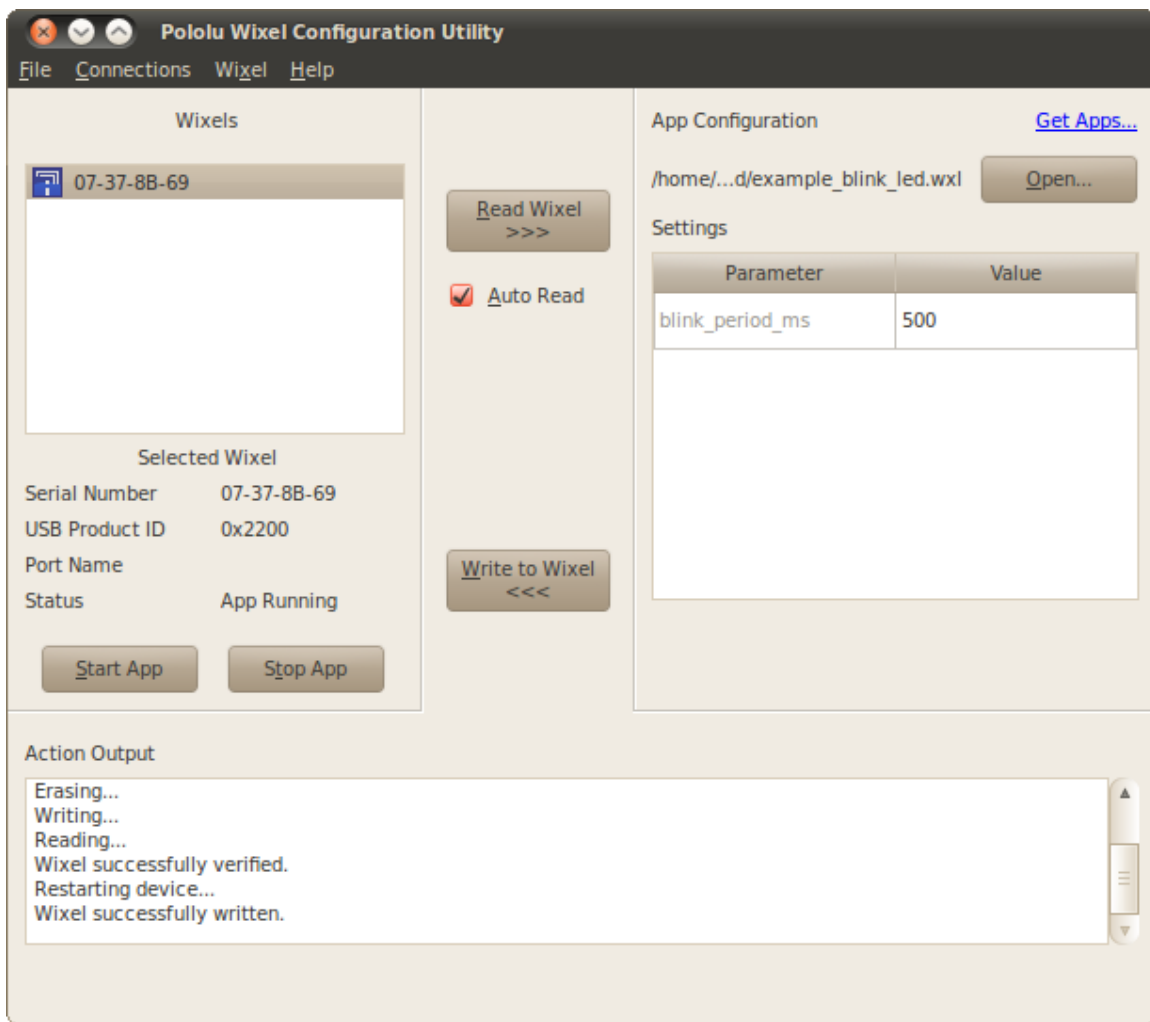

The Wixel Configuration Utility running in Ubuntu Linux.

You can download the Wixel Configuration Utility and the Wixel command-line utility (`wixelcmd`) for Linux here:

- **Wixel Linux Software for i386 &lpar;32-bit** [[https://www.pololu.com/file/download/wixel-linux-110623-i386.tar.gz?file\\_id=0J489](https://www.pololu.com/file/download/wixel-linux-110623-i386.tar.gz?file_id=0J489)] (211k gz)
- **Wixel Linux Software for amd64 &lpar;64-bit** [[https://www.pololu.com/file/download/wixel-linux-110623-amd64.tar.gz?file\\_id=0J490](https://www.pololu.com/file/download/wixel-linux-110623-amd64.tar.gz?file_id=0J490)] (216k gz)

Unzip the tar/gzip archive by running “`tar -xzf`” followed by the name of the file. After following the instructions in `README.txt`, you can run the programs by executing `wixelconfig` or `wixelcmd`.

Any **Wixel app** that implements a USB virtual COM port or a Human Interface Device (HID) will work on Linux with no special driver installation required.

The virtual COM ports are managed by the `cdc-acm` kernel module, whose source code you can find in your kernel’s source code in `drivers/usb/class/cdc-acm.c`. When you connect a Wixel running an app that implements a virtual serial port to the PC, the virtual serial port should appear as a device with a name like `/dev/ttyACM0` (the number

depends on how many other ACM devices you have plugged in). You can use any terminal program (such as `kermi` or `screen`) to send and receive bytes on those ports.

### 3.c. Installing Mac OS X Drivers and Software

**Mac OS X compatibility:** we have confirmed that the Wixel works on Mac OS X 10.7 and we can assist with advanced technical issues, but most of our tech support staff does not use Macs, so basic support for Mac OS X is limited.

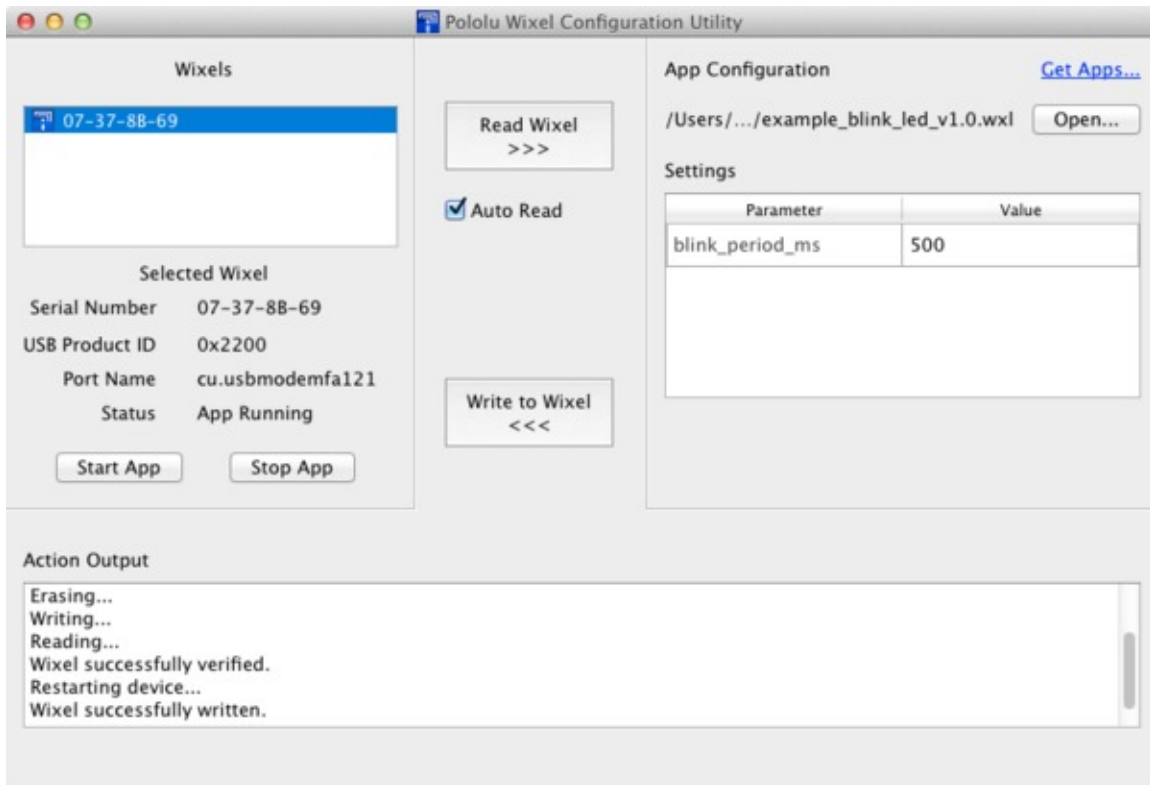

**The Wixel Configuration Utility running in Mac OS X.**

You can download the Wixel Configuration Utility and the Wixel command-line utility (`wixelcmd`) for Mac OS X here:

- **Wixel Mac Software** [[https://www.pololu.com/file/download/wixel-mac-120514.dmg?file\\_id=0J550](https://www.pololu.com/file/download/wixel-mac-120514.dmg?file_id=0J550)] (8MB dmg)

Double click on the dmg file to open it, and then follow the instructions in `README.txt`.

The virtual COM ports are managed by the `AppleUSBCDCACM` component of Mac OS X. The **source code** [<http://www.opensource.apple.com>] of `AppleUSBCDCACM` is available from Apple. When you connect a Wixel running an app that implements a virtual serial port to the PC, the virtual serial port should appear as a device with a name like `/dev/cu.usbmodemfa121` (the number depends on which USB port you use). You can use any terminal program (such as `screen`) to send and receive bytes on those ports.

### 3.d. Loading an Example App

When you first get your Wixel it will have no application loaded. To make your Wixel do something useful, you must load an app onto it. This section guides you through the steps needed to load an example application onto the Wixel using the Wixel Configuration Utility.

1. Install the Wixel drivers and software by following the instructions in the preceding sections.
2. Download the example application here: **Example Blink LED App v1.0** [[https://www.pololu.com/file/download/example-blink-led-v1.0.wxl?file\\_id=0J449](https://www.pololu.com/file/download/example-blink-led-v1.0.wxl?file_id=0J449)] (11k wxl). If you want to see the source code, it is in the Wixel SDK under `apps/example_blink_led`. (See **Section 10.a.**)
3. Open the app in the Wixel Configuration Utility. To do this in Windows, you can simply double-click on the Wixel App (WXL) file. Alternatively, you can open the Wixel Configuration Utility, click the “Open...” button, and select the Wixel App file. In Windows, you can find the Wixel Configuration Utility in the Pololu folder in your Start Menu.
4. Connect a Wixel to your computer via USB. You should see it appear in the “Wixels” list. If it does not appear, you might need to use a button or wire to get your Wixel into bootloader mode (see **Section 5.c**). At this point, your screen should look something like this:



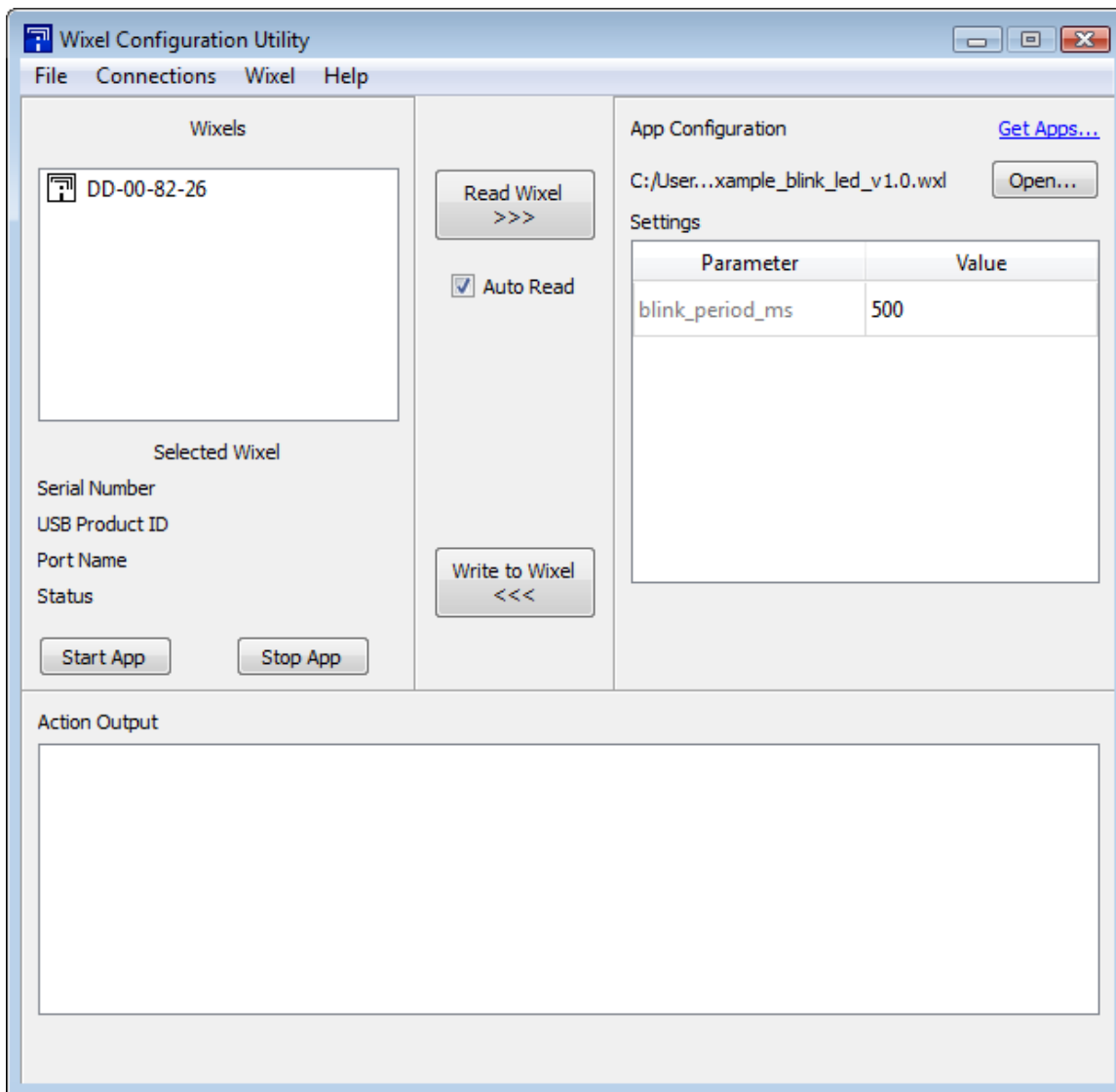

**The Wixel Configuration Utility with the Example Blink LED App open.**

5. Note that in the Wixels box, there is a list of all the Wixels connected to USB that the Wixel Configuration Utility can recognize. There is one Wixel connected, and its 32-bit serial number is displayed in the list. Also note that in the App Configuration box, we have opened the `example_blink_led_v1.0.wxl` app. This app has one parameter, `blink_period_ms`, and it is currently set to 500 (the default).
6. Select the Wixel by left-clicking on its entry in the Wixels list. If you see a dialog box pop up, this is because the Wixel already has an application on it and the Auto Read checkbox is checked. Click the “Cancel” button in that dialog because we are not interested in reading the contents of the Wixel yet.
7. Click the **Write to Wixel** button. This writes the currently open app and the settings to the selected Wixel, and then starts running the application.
8. The example blink LED application should be running now. The Wixel’s yellow LED should be off, and the red LED should be blinking. If you are in Windows XP and this is the first time you have run an application on this Wixel, the Found New Hardware Wizard will pop up and you will have to follow steps 5–9 from **Section 3.a** to install the drivers properly. After the USB drivers are installed properly, the green LED should be on solid. Congratulations, you have successfully configured your Wixel!

9. The speed of the blinking is determined by the `blink_period_ms` parameter. The units of this parameter are milliseconds (ms). Try changing `blink_period_ms` to 100 by double-clicking on the number and typing “100”. You can now write the new configuration to the Wixel by clicking the “Write to Wixel” button. After the writing is done and the app is running, you should see the red LED blinking 5 times faster than it was before.
10. The Wixel Configuration Utility can also read the settings from the Wixel. To demonstrate this, close the Wixel Configuration Utility, reopen it, and select your Wixel. Since the Auto Read checkbox is checked by default, and there is an application on the Wixel, the Wixel Configuration Utility will attempt to read the Wixel's settings. If you have not yet opened the correct app, a dialog box like the one below will pop up:

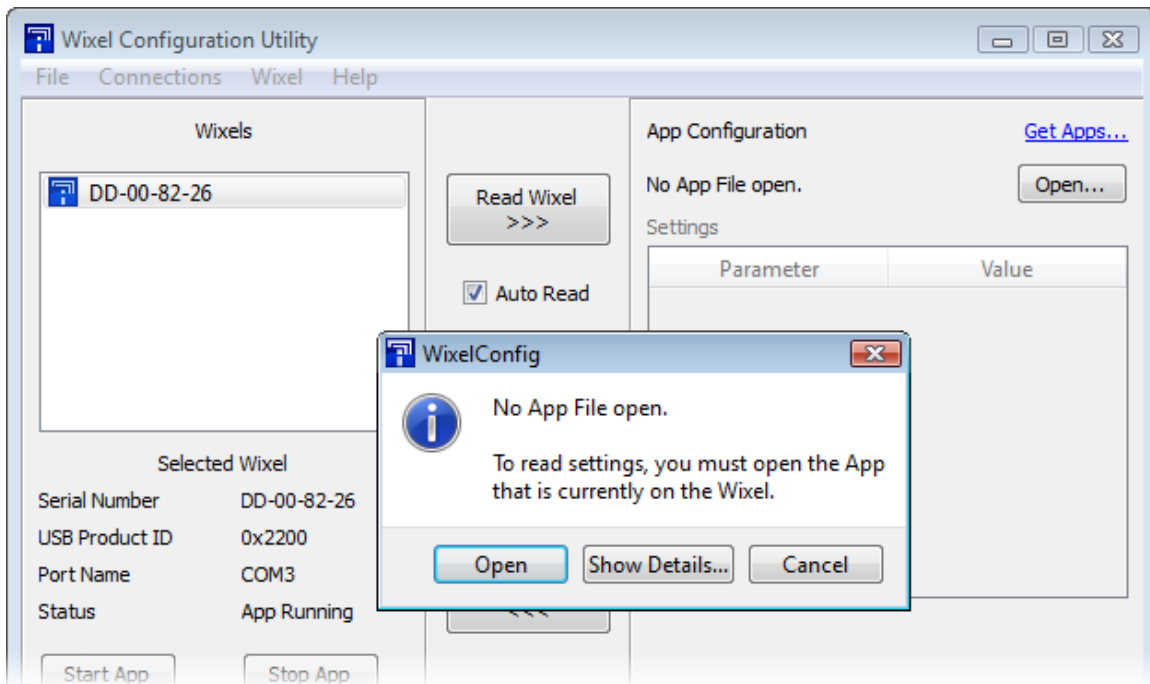

**If Auto Read is enabled when you select a Wixel with an app on it, then you might be prompted you to open the App File.**

11. To read the settings from a Wixel, you will need to open the app that is currently on the Wixel. Click the “Open” button in the dialog, and select `example_blink_led_v1.0.wx1`.



It is necessary to open the app file that you originally loaded onto the Wixel because the file contains metadata required to interpret the settings contained in the Wixel's flash memory. If you open a different app file, even a different version of the same app, your settings will likely be corrupted. In this case, a warning dialog box will pop up to warn you and give you some options. Since you still have the correct app file, you should not see that dialog now.

12. After you open the Wixel App file, the Wixel Configuration Utility will read the Wixel and compare its contents to what is in the app. You will then see the Wixel's settings displayed on the right: `blink_period_ms` should be 100. Note that the number 100 is displayed in bold. This is because it differs from the default setting, which is 500. You can reset it to the default at any time by right-clicking on the number and selecting “Reset to Default Value”.

After completing this tutorial you should be comfortable with writing apps to the Wixel and reading back the settings. This is all you need to know in order to configure your Wixels. When you load a real application, such as the **Wireless**

**Serial App** [<https://www.pololu.com/docs/0J46/9.b>], the only thing that will be different are the names and meanings of the parameters. To understand what the different parameters mean, refer to the documentation for your specific app.

Some apps might implement a non-standard USB interface (or no USB interface at all). In that case, they will not be recognized by the Wixel Configuration Utility while the app is running, so you will need to get them into bootloader mode manually (see **Section 5.c** and also the app's documentation).

## 4. Configuring Your Wixels

The Wixel Configuration Utility allows you to write and read settings from the Wixel. This section explains all of the features of the Wixel Configuration Utility in detail.

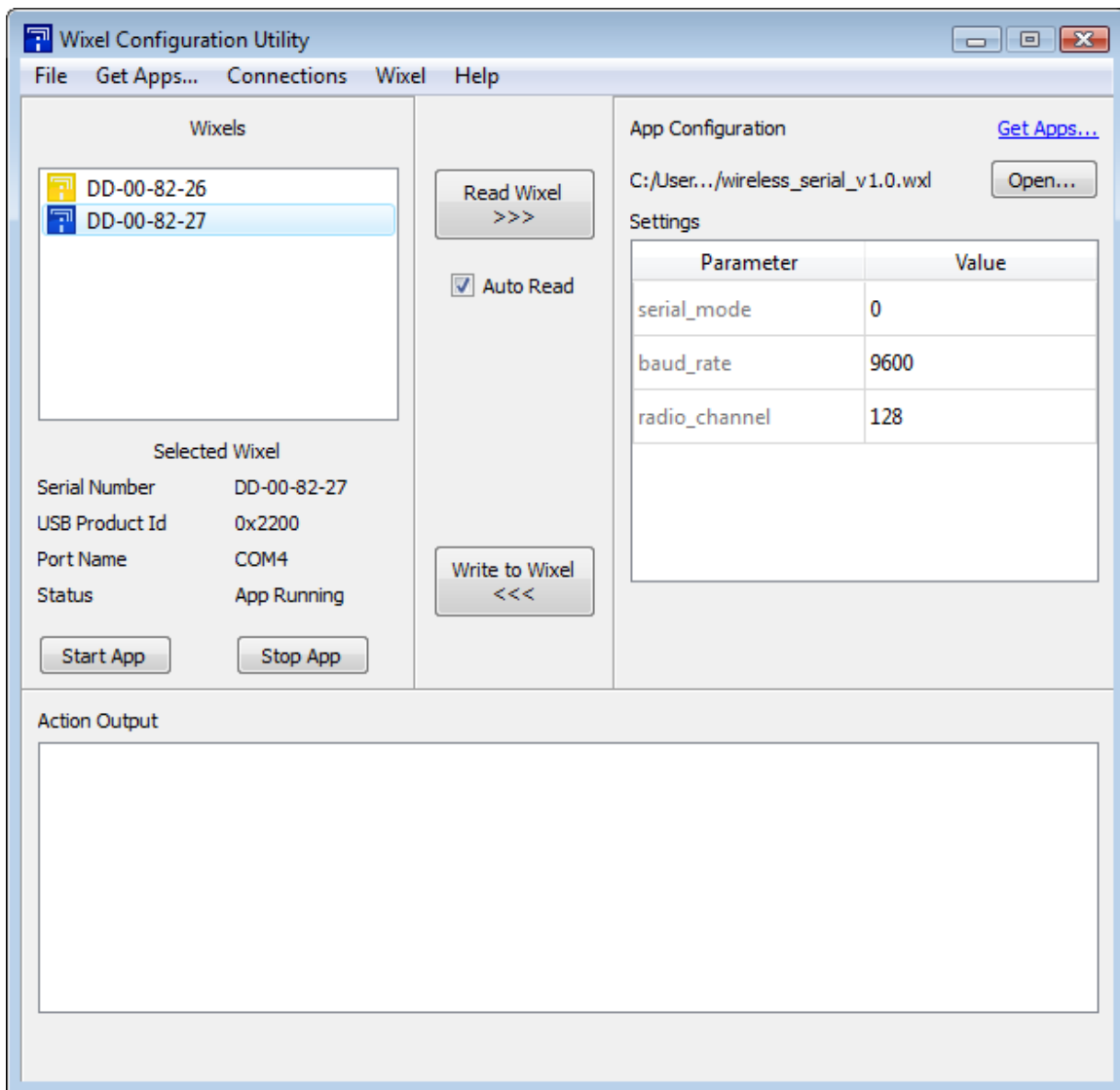





The Wixel Configuration Utility with 2 Wixels connected and an App file open.

### Wixels

On the left side of the window, in the Wixels box, you can see a list of all the Wixels connected to the computer that are recognized by the Wixel Configuration Utility. The Wixel Configuration Utility should recognize any Wixel that is in bootloader mode (i.e. the app is stopped) or is running an app that implements a single USB Virtual COM port with a USB Vendor ID of 0x1FFB (for Pololu) and a Product ID of 0x2200. If your Wixel is connected to your computer, but does not show up in the Wixel Configuration Utility, then your drivers might not be installed properly, or the Wixel might be running an application that uses a different type of USB interface or doesn't use USB at all. If you have trouble getting the Wixel Configuration Utility to recognize your Wixel, then see **Section 10** for help.

The text displayed in the Wixel list (e.g. “07-C2-C8-3A”) is the serial number of your Wixel. Each Wixel has a unique 32-bit serial number which was randomly generated and assigned to it when the Wixel was manufactured.

The icon displayed in the Wixel list represents the current state of the Wixel. Each Wixel will be in one of these states:

Wixel Status	Icon	Description
App Running		The app you loaded on the Wixel is now running.
App Stopped		The app you loaded on the Wixel is currently stopped; the Wixel is in bootloader mode.
No App		There is no app on the Wixel; the Wixel is in bootloader mode.
Reconnecting		The Wixel is reconnecting, disconnecting, or in a transitional state.

If you select a Wixel, you can see more information about it in the area below the list. The **USB Product ID** is the current product ID presented by the Wixel on its USB interface, as defined in the USB Specification. The **Port Name** is the name of the virtual COM port that has been assigned to the Wixel. In Windows, the Port Name is also available in the Device Manager.

The **Stop App** button stops the application that is running on the currently-selected Wixel, putting that Wixel into bootloader mode. The **Start App** button takes the Wixel out of bootloader mode to run the application that is currently on it.

### App Configuration

On the right side of the window, in the App Configuration box, you can see the name of the currently-open app and the current settings.

You can open a different app by clicking the “Open...” button. In Windows, you can also open an app simply by double-clicking on it. The Wixel Configuration Utility can open app files in either the WXL format (documented in **Section 9.d**) or the standard **Intel HEX** ([http://en.wikipedia.org/wiki/Intel\\_HEX](http://en.wikipedia.org/wiki/Intel_HEX)) format.

You can change the current settings by double-clicking on a value and typing a new value in. The parameters that are available depend on the app that is open; different apps have different parameters available.

Please see the documentation for your specific application for an explanation of what the parameters mean, and what the valid values are. The Wixel Configuration Utility will **not** prevent you from entering invalid or inconsistent values.

### Writing to a Wixel

After you have chosen the app and settings you want to use, and selected a Wixel, you can write the app and settings to the Wixel by clicking the **Write to Wixel** button. This will erase whatever application was previously on the Wixel and write the new application to the Wixel. When the write operation is done, the Wixel will be restarted and the application should start running.

### Reading from a Wixel

To read the settings from a Wixel that has been programmed, select the Wixel. If the **Auto Read** checkbox is checked, then the Wixel will automatically be read. Uncheck this box if you want to retain current settings when changing

Wixels (for example, when you want to write the same app and settings to multiple Wixels). If the box is unchecked, you can click the **Read Wixel** button at any time to read settings from the selected Wixel.

To read the settings from a Wixel, you will need to open the app that is currently on the Wixel. This is necessary because the app file contains metadata which is needed in order to correctly interpret the settings contained in the Wixel's flash memory.

If you have lost the app file and want to read the contents of your Wixel, select **Read Flash and Export to HEX File...** from the Wixel menu. You can then open the exported HEX File as an App and use it to program other Wixels. The settings from the Wixel will be contained in the exported HEX file but you will not be able to read these settings in the Wixel Configuration Utility.

If the Wixel's application is running when the read operation starts, the Wixel Configuration Utility will temporarily stop the application and put the Wixel into bootloader mode in order to read its contents. When the read operation is completed, the Wixel Configuration Utility will restart the app.

### Other Commands

The **Erase Wixel** command (found in the Wixel menu) erases the app from the currently selected Wixel (every bit in the application flash section becomes a 1).

The **Verify Wixel** command reads the currently selected Wixel and tells you whether its contents are identical to the app and settings displayed on the right in the App Configuration box.

## 5. Connecting Your Wixels

This chapter explains some of the electrical connections you might need to make to get your Wixel working the way you want it to.

### 5.a. Connecting Power

The two main ways of powering the Wixel are the USB port and the VIN pin. The schematic of the Wixel's power system is shown below:

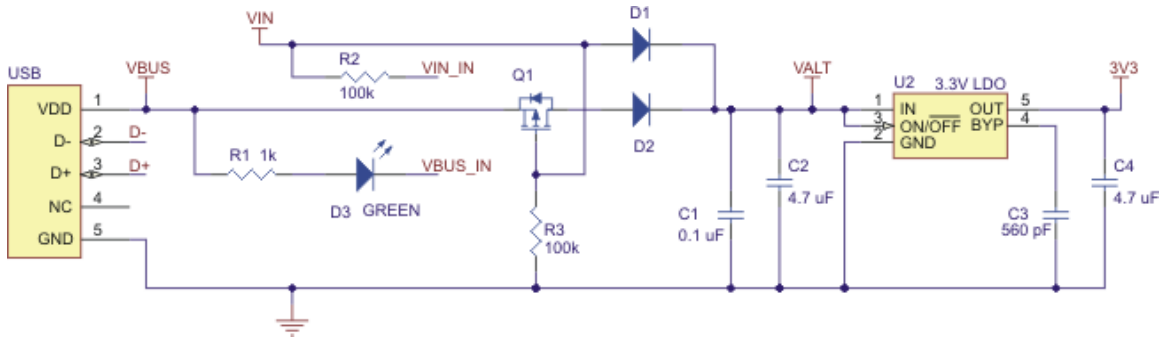

**Wixel power system schematic diagram.**

### VIN Power Input

The Wixel can be powered from VIN if you connect a 2.7–6.5 V power supply (e.g. battery or regulator) to the GND and VIN pins. The negative terminal should be connected to GND. The positive terminal should be connected to VIN. It is okay to have both USB and VIN connected at the same time.

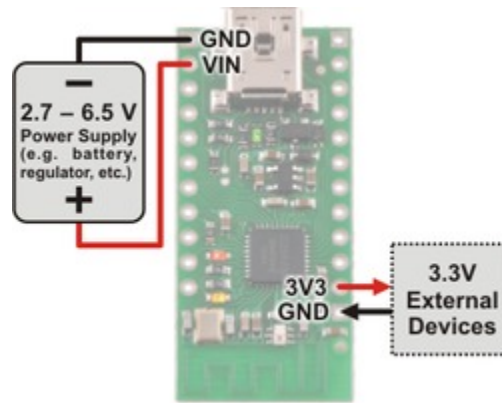

**The Wixel can be powered from an external power source connected to VIN.**

### USB Power Input

The Wixel can be powered from USB if you connect a USB cable and leave VIN disconnected. The Wixel will draw its power from USB if VIN is disconnected or it is below about 4 V.

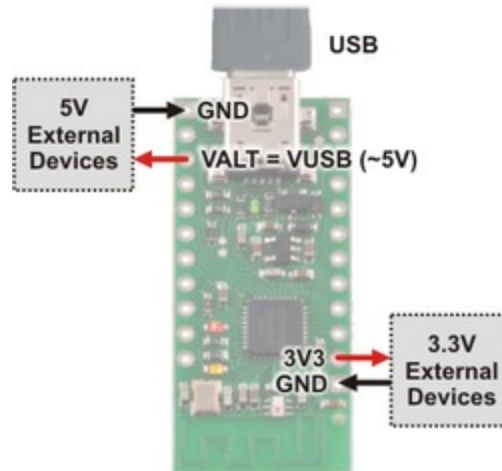

The Wixel can be powered from USB.

### 3V3 Power Output

The Wixel's 3V3 pin gives access to the output of the Wixel's 3.3 V regulator. If the Wixel's power supply drops below approximately 3.5 V, the 3V3 output will be less than 3.3 V. Normally this output can provide up to 150 mA, but if the Wixel's power supply is above 5 V then it is limited to 100 mA. You can use 3V3 to power your own 3.3 V devices.

### VALT Power Output

VALT provides access to the input pin of the Wixel's 3.3 V regulator, which is connected through a diode to VIN or to the USB bus voltage, depending on which power source is connected. You can use VALT to power your own circuits as long as you do not draw more than about 500 mA.

For example, if you leave VIN disconnected, VALT can power 5V devices.

### Low Power Considerations

The CC2511F32 is capable of a sleep mode (PM2) where the chip draws less than 1  $\mu\text{A}$  and is still capable of waking itself up. Without modifying the Wixel's hardware, it is possible to power it from VIN and get the current consumption down to around 100  $\mu\text{A}$ . Most of that current is consumed by the Wixel's 3.3 V regulator. To get rid of it, you will need to sever the output pin of the regulator and power the Wixel directly from the 3V3 pin with a 2.0–3.6 V power supply. For details on how to do this, please contact Pololu.

Please note that currently none of the Wixel apps support low power modes, so the Wixel will draw approximately 30 mA at all times. To make your Wixel operate with low power you would have to write your own app or modify one of the existing apps. You will need to make sure that all of the I/O lines are either outputs or get pulled high or low: an input line at an intermediate voltage can consume several microamps of extra current.

### 5.b. Connecting a Microcontroller via TTL Serial

If you have loaded a Wixel app that employs one of the Wixel's two UARTs (such as the **Wireless Serial App** [<https://www.pololu.com/docs/0J46/9.b>]), then the Wixel can communicate with another microcontroller via asynchronous, non-inverted TTL serial. Communication between the Wixel and an RS-232 device requires additional hardware.



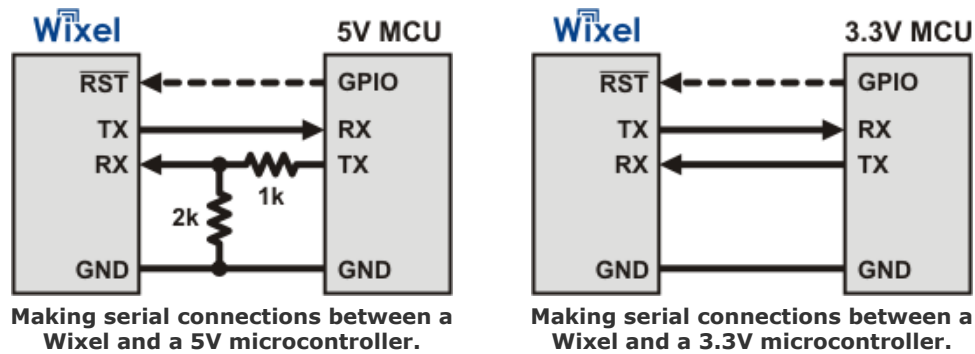

To connect your microcontroller to a Wixel for serial communication, make these connections:

- **GND:** Connect the ground (also known as GND or VSS) of your microcontroller to one of the GND pins on the Wixel. This connection is required.
- **TX:** If you want the microcontroller to be able to receive serial bytes from the Wixel, connect the Wixel's TX line to the microcontroller's RX line.
- **RX:** If you want your microcontroller to be able to send serial bytes to the Wixel, connect the microcontroller's TX line to the Wixel's RX line. The Wixel's RX line is **not** 5 V tolerant. If your microcontroller is running at 5 V (or any voltage significantly above 3.3 V) then you will need to add extra components to ensure that your microcontroller never drives the Wixel's RX line higher than 3.3 V. A simple voltage divider consisting of 2 resistors as shown in the diagram above will suffice. The Wixel's RX line has an internal 20 kΩ pull-up resistor.
- **RST:** If you want the microcontroller to be able to reset the Wixel, then connect the Wixel's  $\overline{\text{RST}}$  line to any free general-purpose I/O (GPIO) line on the microcontroller. The microcontroller can drive this line low to reset the Wixel and then stop driving the line to release the Wixel from reset. The Wixel's  $\overline{\text{RST}}$  line is **not** 5 V tolerant. If your microcontroller is running at 5 V (or any voltage significantly above 3.3 V) then you must avoid driving the Wixel's  $\overline{\text{RST}}$  line high. If that is not possible, then you could put a diode between the Wixel's  $\overline{\text{RST}}$  line and the microcontroller's GPIO to prevent current from flowing in the wrong direction (from the GPIO). The connection to  $\overline{\text{RST}}$  is optional and not required for sending or receiving data.

Please refer to the documentation of your specific Wixel app to determine the location of the TX pin(s) and RX pin(s).

**Note:** The Wixel does **not** support the RS-232 voltage levels typically used by DB9 serial ports. The Wixel's I/O lines, including the RX and TX lines, operate on voltages between 0 and 3.3 V are **not** 5 V tolerant. To connect the Wixel to an RS-232 serial signal, you will need additional level-shifting and inverting hardware like the **Pololu 23201a serial adapter** [<https://www.pololu.com/product/126>] (RS-232 serial is inverted; the Wixel's serial interface expects non-inverted serial).

### 5.c. Connecting Buttons and Starting the Bootloader

In order to load a new app or new settings onto your Wixel (or read the Wixel's flash memory) you will need to get it into bootloader mode. Most Wixel apps support a special USB command for putting the Wixel into bootloader mode and the Wixel Configuration Utility can send that command automatically when you try to access the Wixel's flash. However you might find yourself in a situation where that method will not work. This can happen for two reasons:

- You accidentally loaded a malfunctioning program onto the Wixel that is incapable of responding to the special USB command.

- You loaded a program which uses a different type of USB interface or no USB interface. In this case, check the documentation of the app to see if there is a convenient way for getting the Wixel into bootloader mode.

No matter what state the Wixel is in, you can manually get it into bootloader mode by connecting USB, setting P2\_2 high, and resetting the Wixel.

There are two main ways to accomplish this.

One way is to disconnect the Wixel from any possible power sources, connect P2\_2 to 3V3 using a wire, and then plug it into USB.

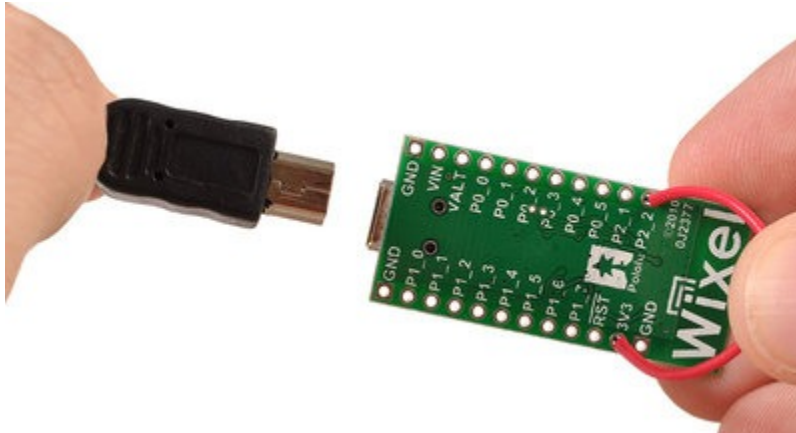

Using a wire to put the Wixel into bootloader mode.

Another way is to wire a bootloader button and a reset button to the Wixel and follow the procedure shown in the picture below:

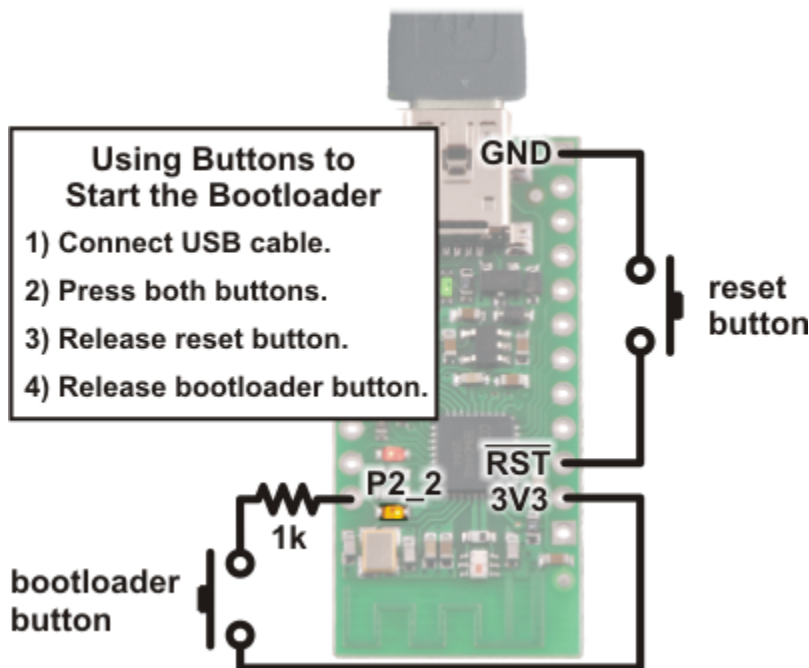

Using pushbuttons to put the Wixel into bootloader mode.

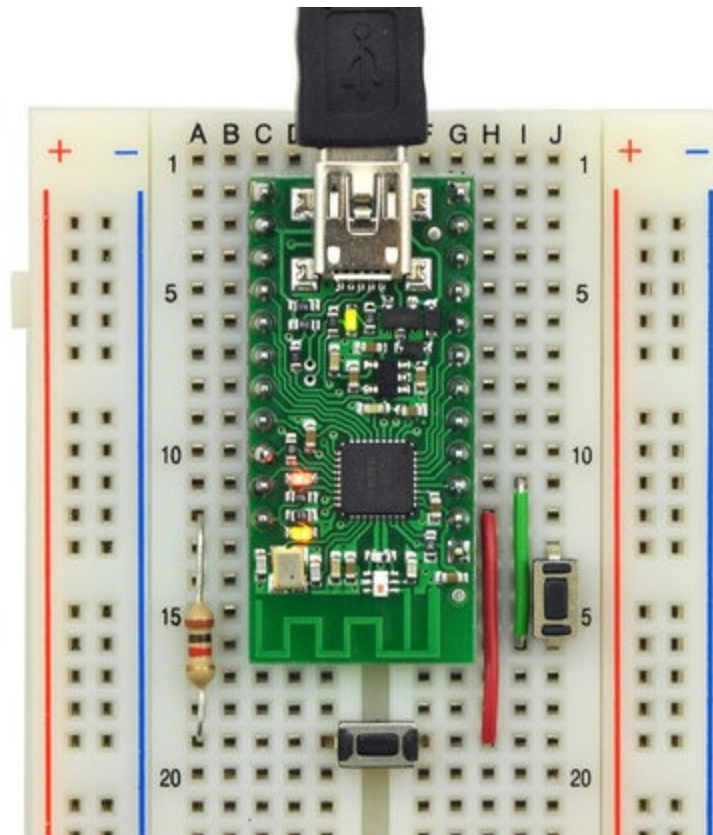

**Wixel on breadboard with a bootloader button and reset button connected.**

## 6. Using a Virtual COM Port

Most of the available Wixel apps implement a USB interface that consists of a single virtual COM (serial) port. This interface allows you to send and receive bytes from the Wixel in the same way you would send and receive bytes from any other serial port on your computer.

### 6.a. Determining the Port Name

To connect to a COM port, you usually have to know the name of the port.

In Windows, the port name will be something like “COM4” and you can determine the port name by selecting the Wixel in the Wixel Configuration Utility and looking at the “Port Name” property displayed below. You can also find out the port name by looking the “Ports (COM & LPT)” list in your Device Manager.



Windows Tip: Besides having names like “COM5” and “COM6”, the virtual COM ports provided by the Wixel also have names like “\\.\USBSER000” and “\\.\USBSER001”. These names are assigned sequentially whenever a device with a virtual COM port is plugged in. If you only have one device with a virtual COM port plugged into your computer, the name “\\.\USBSER000” will usually be assigned to it. These names will work with most programs that allow you to specify arbitrary port names.

### 6.b. Using a Terminal Program

There are many free terminal programs available which are capable of sending and receiving bytes on a virtual COM port. These programs include **PuTTY** [<http://www.chiark.greenend.org.uk/~sgtatham/putty/>] (Windows or Linux), **Tera Term** [<http://ttssh2.sourceforge.jp/>] (Windows), and **Br@y Terminal** [<http://sites.google.com/site/terminalbpp/>] (Windows). Advanced users developing scripted applications may prefer the free terminal program **kermit** [<http://www.columbia.edu/kermit/ck80.html>]. To use any of these terminal programs with the Wixel, you must specify the port name (see **Section 6.a**) and the baud rate. The baud rate may or may not affect anything; see your application's documentation. The characters you type will be transmitted on the programmer's **TX** line. Bytes received by the programmer on the **RX** line will be displayed on the screen by the terminal program.

Typical terminal programs will allow you to choose several other settings besides the baud rate. If you are not sure what settings to use, then you should pick 8 data bits, 1 stop bit, no parity, and no flow control.

Typical terminal programs will not allow you to use the serial control signals, but Br@y terminal does. You can click the “DTR” and “RTS” buttons to change the state of the DTR and RTS signals. The state of the CTS, CD, DSR, RI, DTR, and RTS signals are indicated by the colors of the corresponding buttons.

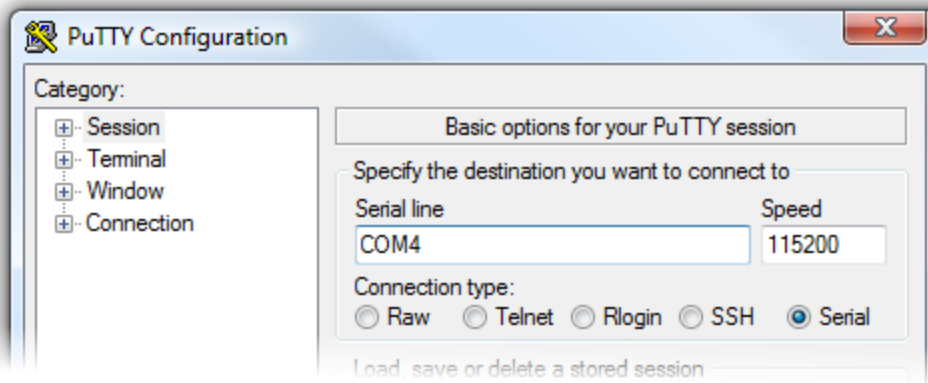

**PuTTY is a free Windows terminal program that can send and receive bytes on a serial port.**

If you need to send and receive non-ASCII bytes, you can use the **Pololu Serial Transmitter Utility for Windows** [<https://www.pololu.com/docs/0J23>] or Br@y Terminal.

### 6.c. Writing PC Software to Use a Serial Port

You can write your own computer program that communicates with a serial port. The freely available Microsoft .NET framework contains a **SerialPort** [<http://msdn.microsoft.com/en-us/library/system.io.ports.serialport.aspx>] class that makes it easy to read and write bytes from a serial port. Here is some example C# .NET code that uses a serial port:

```
// Choose the port name and the baud rate.
System.IO.Ports.SerialPort port = new System.IO.Ports.SerialPort("COM4", 115200);

// Connect to the port.
port.Open();

// Transmit two bytes on the TX line: 1, 2
port.Write(new byte[]{1, 2}, 0, 2);

// Wait for a byte to be received on the RX line.
int response = port.ReadByte();

// Show the user what byte was received.
MessageBox.Show("Received byte: " + response);

// Disconnect from the port so that other programs can use it.
port.Close();
```

## 7. Ensuring a Good Radio Signal

Here are some tips for improving the quality of the radio signals sent between a pair of Wixels:

- Reduce the distance between the Wixels, if possible.
- Try different frequencies. Most Wixel apps that use the radio have a *radio\_channel* parameter that determines what frequency will be used. By switching to a different channel you might be able to avoid interference from other nearby 2.4 GHz radios. You might even want to buy a spectrum analyzer such as the **Wi-Spy** [<http://www.metageek.net/products/wi-spy/>] to find out which frequencies in your area have the least activity.
- Remove objects that are very close to the Wixel's antenna. For example, if the Wixel has no header pins installed and it is resting flat on your desk, find a way to get the Wixel at least an inch or two above the desk.
- Reduce obstructions between the two Wixels. Many objects can interfere with 2.4 GHz radio waves, including walls, trees, people and anything with water in it.
- Try different Wixel orientations. The Wixel's antenna sends and receives better in some directions than others.

## 8. Schematic Diagram

The schematic diagram of the Wixel is shown below:

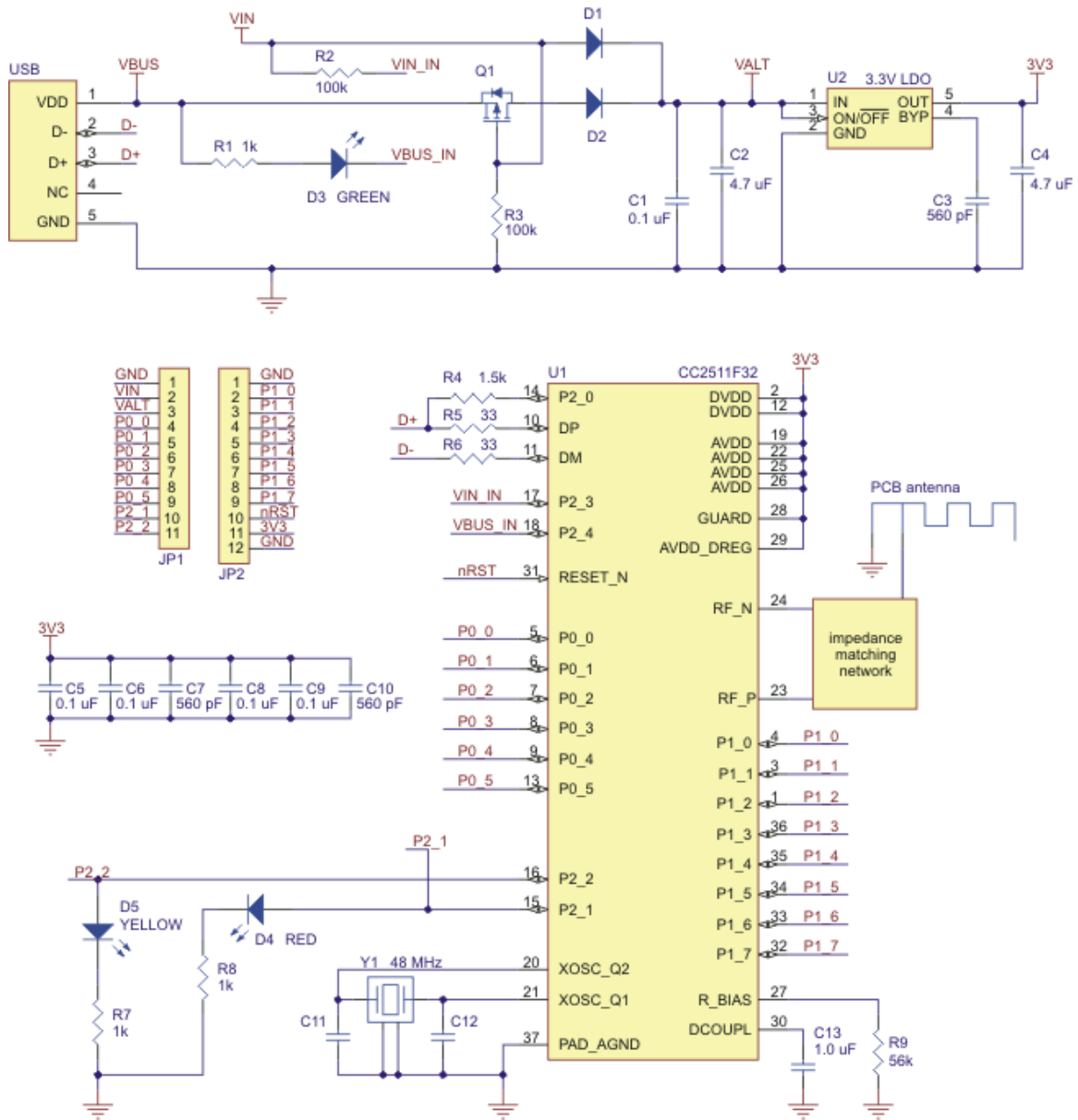

The schematic also available as a **printable pdf** [[https://www.pololu.com/file/download/wixel\\_schematic.pdf?file\\_id=0J463](https://www.pololu.com/file/download/wixel_schematic.pdf?file_id=0J463)] (51k pdf).

## 9. Wixel Apps

This section describes some of the available Wixel apps written by Pololu; you can find their source code in the Wixel SDK (see **Section 10**). For more apps, including ones written by community members, see the Wixel SDK and the **Wixel Apps forum thread** [<http://forum.pololu.com/viewtopic.php?f=30&t=5165>].

### 9.a. Example App: Blink LED

This is an example app that blinks the red LED with a configurable period. See **Section 3.d** for a tutorial on using this app.

Download link: **Example Blink LED App (v1.0)** [[https://www.pololu.com/file/download/example-blink-led-v1.0.wxl?file\\_id=0J449](https://www.pololu.com/file/download/example-blink-led-v1.0.wxl?file_id=0J449)] (11k wxl)

### 9.b. Wireless Serial App

#### Overview

This app allows you to connect two Wixels together to make a wireless, bidirectional, lossless serial link. It uses an RF bit rate of 350 kbps, is capable of carrying up to 10 KB of payload data per second, and can reach a range of approximately 50 feet (under typical conditions indoors). You can also use it to turn one Wixel into a USB-to-TTL serial adapter.

This app can run on multiple pairs of Wixels as long as each pair operates on a different radio channel (the channels should be separated by 2 to avoid interference).

This app is designed for pairs of Wixels; it will **not** work properly if three or more Wixels are broadcasting on the same radio channel.

#### Installation Instructions

Download the **Wireless Serial App (v1.3)** [[https://www.pololu.com/file/download/wireless-serial-v1.3.wxl?file\\_id=0J484](https://www.pololu.com/file/download/wireless-serial-v1.3.wxl?file_id=0J484)] (26k wxl). Open it with the Wixel Configuration Utility, choose your parameters, and then write it to two Wixels. See **Section 4** for more information on how this is done.

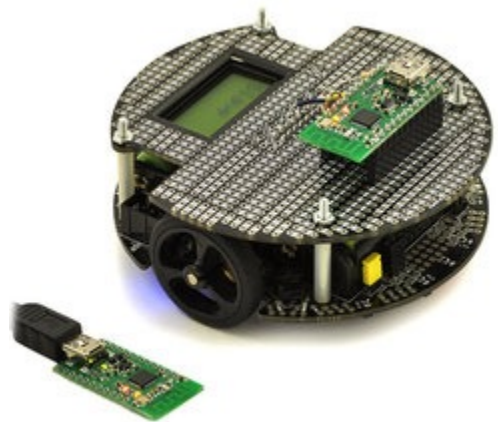

Wireless PC control of a 3pi robot using a pair of Wixels.



Together, the USB Adapter A to Mini-B and a Pololu Wixel wireless module can make a compact USB dongle.



## Default Pinout

Pin	Function	
P1_0	$\overline{\text{DTR}}$	general-purpose output pin
P1_1	$\overline{\text{RTS}}$	general-purpose output pin
P1_2	$\overline{\text{DSR}}$	general-purpose input pin
P1_3	$\overline{\text{CD}}$	general-purpose input pin
P1_5	PA_PD	radio transmit debug output
P1_6	TX	transmits serial data (0–3.3 V)
P1_7	RX	receives serial data (0–3.3 V, not 5 V tolerant)
P0_0	Arduino DTR	for wireless Arduino programming when used with the <a href="#">Wixel shield</a>

## Description

This device appears to the USB host as a Virtual COM Port (with USB product ID 0x2200). If you are using Windows, you should see an entry labeled “Wixel” in your Device Manager in the “Ports (COM & LPT)” category while the app is running.

There are three basic serial modes that can be selected:

1. USB-to-Radio: Serial bytes from the USB virtual COM port get sent to the radio and vice versa.
2. UART-to-Radio: Serial bytes from the UART's RX line get sent to the radio and bytes from the radio get sent to the UART's TX line.
3. USB-to-UART: Just like a normal USB-to-TTL serial adapter, bytes from the virtual COM port get sent on the UART's TX line and bytes from the UART's RX line get sent to the virtual COM port.

You can select which serial mode you want to use by setting the **serial\_mode** parameter to the appropriate number (from the list above) or you can leave the serial mode at 0 (which is the default). If the serial\_mode is 0, then the Wixel will automatically choose a serial mode based on how it is being powered as described in the table below, and it will switch between the different serial modes on the fly.

### Auto-Detect Serial Mode (serial\_mode = 0)

Power Source	Serial Mode
USB only	USB-to-Radio
VIN only	UART-to-Radio
USB and VIN	USB-to-UART

The RX pin has an internal 20 k $\Omega$  pull-up resistor.

The PA\_PD pin (P1\_5) is a debugging output that goes low while the Wixel is transmitting a packet on the radio.

The serial data format used by this app is 8 data bits, one stop bit, with no parity, which is often expressed **8-N-1**. The data is non-inverted, so 0 V represents 0 and 3.3 V represents 1.

## Indicator LEDs

The **green** LED behaves as described in **Section 1.a**, and also flickers when there is data transferred over USB.

The **yellow** LED represents the state of the radio. If the Wixel is in a serial mode where the radio is not used, the yellow LED will be off. Otherwise, the yellow LED turns on and off slowly until radio communication is established for the first time, after which it blinks briefly once per second and flickers whenever data is sent or received via the radio.

The **red** LED indicates errors. The red LED will flash briefly if a byte is received on the UART's RX line that had to be discarded because the receive buffers were full. The red LED will turn on when a framing error occurs on the RX line and will stay on until the RX line goes high.

## Control Signals

In addition to relaying bidirectional serial data, this app also relays the values of four control signals: DTR, RTS, DSR, and CD. The names of these control signals come from the RS-232 protocol, but in this app they do not actually have the same role as they have in that protocol: they are general purpose digital control signals that can carry any kind of data that you want them to, as long as that data changes slowly (on the order of 5 Hz or slower) and is limited to two bits in each direction.

In USB-to-Radio mode, the DTR and RTS signals from USB are transmitted wirelessly to the other Wixel, while the control signals wirelessly received from the other Wixel are relayed to USB as DSR and CD.

In UART-to-Radio mode, the DSR and CD signals from the digital input pins are transmitted wirelessly to the other Wixel, while the control signals wirelessly received from the other Wixel are relayed to the DTR and RTS output pins.

In USB-to-UART mode, the DTR and RTS signals from USB are relayed to the corresponding output pins, while the values of the DSR and CD input pins are relayed to USB.

If two Wixels are communicating wirelessly with each other and both are in UART-to-Radio mode or both are in USB-to-Radio mode, then the correspondence between the control lines is as follows: DSR on one Wixel corresponds to DTR on the other Wixel, while RTS on one Wixel corresponds to CD on the other Wixel.

The default configuration of this app (as shown in the table above) gives the Wixel two inverted output pins ( $\overline{\text{DTR}}$  and  $\overline{\text{RTS}}$ ), and two inverted input pins ( $\overline{\text{DSR}}$  and  $\overline{\text{CD}}$ ). These pins are **inverted**, which means that a logical value of 0 corresponds to high voltage (usually 3.3 V), while a logical value of 1 corresponds to 0 V (GND).

By changing the configuration parameters (see below), you can disable these signals, reassign them to different I/O lines, or add non-inverted inputs and outputs.

Any pin configured as an input will have an internal 20 k $\Omega$  pull-up resistor unless it is assigned to P1\_0 or P1\_1, which do not have pull-up or pull-down resistors.



You do not have to connect anything to the control signal pins in order to send and receive serial data. These pins are optional.

## General Parameters

- **serial\_mode**: Selects the serial mode (1–3, see list above) or auto-detect serial mode (0). The default is 0.

- **baud\_rate:** The baud rate to use for the UART, in bits per second. The default is 9600. We recommend not exceeding 115200. This parameter has no effect on serial communication over the virtual COM port (USB).
- **radio\_channel:** The channel number is from 0 to 255 and determines which frequency to broadcast on. The default is 128. Wixels must be on the same channel to communicate with each other. To avoid interference, Wixels that aren't supposed to talk to each other should be at least 2 channels away from each other. For example, you could have one pair of Wixels on channel 128 and another pair on 130.
- **framing\_error\_ms:** The approximate number of milliseconds to disable the UART's receiver for after encountering a framing error on the RX line. Valid values are 0–250. The default is 0, which means that the UART's receiver will not get disabled after a framing error.

### Pin Assignment Parameters

The following parameters can be used to reassign the control signals to different pins on the Wixel. The value of each parameter must be the number of an unused pin on the Wixel. The number can be computed by multiplying the first digit in the pin name by 10 and adding it to the second digit in the pin name. For example, if you wanted to assign the  $\overline{\text{DSR}}$  pin to P1\_2, you would set **nDSR\_pin** to 12. To disable a signal (assign it to no pin), set the corresponding parameter to -1.

- **nDTR\_pin:** The pin assignment for the inverted  $\overline{\text{DTR}}$  output. The default is 10 (P1\_0).
- **nRTS\_pin:** The pin assignment for the inverted  $\overline{\text{RTS}}$  output. The default is 11 (P1\_1).
- **nDSR\_pin:** The pin assignment for the inverted  $\overline{\text{DSR}}$  input. The default is 12 (P1\_2).
- **nCD\_pin:** The pin assignment for the inverted  $\overline{\text{CD}}$  input. The default is 13 (P1\_3).
- **DTR\_pin:** The pin assignment for the non-inverted DTR output. The default is -1 (disabled).
- **RTS\_pin:** The pin assignment for the non-inverted RTS output. The default is -1 (disabled).
- **DSR\_pin:** The pin assignment for the non-inverted DSR input. The default is -1 (disabled).
- **CD\_pin:** The pin assignment for the non-inverted CD input. The default is -1 (disabled).
- **arduino\_DTR\_pin:** The pin assignment for an output for wireless Arduino programming when used with the **Wixel shield** [<https://www.pololu.com/product/2500>]. The default is 0 (P0\_0).

You should not simultaneously enable the non-inverted and inverted *input* for the same signal. Specifically, either **nCD\_pin** or **CD\_pin** should be -1 and either **nDSR\_pin** or **DSR\_pin** should be -1.

### Example Uses

1. This application can be used to make a wireless serial link between two microcontrollers, with no USB involved (except for initially configuring the Wixels). To do this, use the UART-to-Radio mode on both Wixels.
2. This application can be used to make a wireless serial link between a computer and a microcontroller. Use USB-to-Radio mode on the Wixel that is connected to the computer and use UART-to-Radio mode on the Wixel that is connected to the microcontroller. If you are powering both Wixels in the usual way, you should be able to use auto-detect serial mode (`serial_mode = 0`).
3. If you are doing option 2 above and using the the auto-detect serial mode (`serial_mode = 0`), then you have the option to (at any time) plug a USB cable directly into the Wixel that is connected to your microcontroller to establish a more direct (wired) serial connection with the microcontroller. (You would, of course, have to tell your computer to switch to the other COM port when you do this.)

## Caveats

Data will be lost if the Wixel receives bytes on the RX line faster than the radio can convey them to the other Wixel. If you have trouble, try reducing the amount of data sent to the RX line by lowering the baud rate or adding delays to your microcontroller's code.

**Caution:** The Wixel's I/O lines are **not** 5V tolerant. You must use level-shifters, diodes, or voltage dividers to connect the Wixel to outputs from 5V systems. Also, avoid drawing more current from an I/O line than it can provide (see the discussion of P1\_0 and P1\_1 in **Section 1.a**). Avoid connecting multiple output pins together.

The Wixel does **not** support the RS-232 voltage levels typically used by DB9 serial ports. The Wixel's I/O lines, including the RX and TX lines, operate on voltages between 0 and 3.3 V. To connect the Wixel to an RS-232 serial signal, you will need additional level-shifting and inverting hardware like the **Pololu 23201a serial adapter** [<https://www.pololu.com/product/126>] (RS-232 serial is inverted; the Wixel's serial interface expects non-inverted serial).

## Versions

- **Wireless Serial App v1.3** [[https://www.pololu.com/file/download/wireless-serial-v1.3.wx1?file\\_id=0J484](https://www.pololu.com/file/download/wireless-serial-v1.3.wx1?file_id=0J484)] (26k wxl), released 2011-06-20: Added the `framing_error_ms` parameter and the corresponding feature for disabling the UART's receiver after a framing error. Changed the behavior of the red and yellow LEDs; in previous versions the red LED was off and the yellow LED simply indicated the presence of VIN power.
- **Wireless Serial App v1.2** [[https://www.pololu.com/file/download/wireless-serial-v1.2.wx1?file\\_id=0J468](https://www.pololu.com/file/download/wireless-serial-v1.2.wx1?file_id=0J468)] (24k wxl), released 2011-04-06: Added support for control signals. As a result, the radio protocol used is **NOT compatible with earlier versions**. Also fixed a glitch on the TX line that occurred upon power-up or reset. Added blinking behavior to the green LED to indicate USB data transfer.
- **Wireless Serial App v1.1** [[https://www.pololu.com/file/download/wireless-serial-v1.1.wx1?file\\_id=0J461](https://www.pololu.com/file/download/wireless-serial-v1.1.wx1?file_id=0J461)] (18k wxl), released 2011-03-23: Improved the radio protocol to fix a problem in v1.0 where if one Wixel resets but the other Wixel does not, then (depending on the state of the other Wixel) there is a 50% probability that the next radio packet sent in either direction will be ignored by the receiver.
- **Wireless Serial App v1.0** [[https://www.pololu.com/file/download/wireless-serial-v1.0.wx1?file\\_id=0J447](https://www.pololu.com/file/download/wireless-serial-v1.0.wx1?file_id=0J447)] (18k wxl), released 2011-03-22: Initial release.

## Versions Configured for the Wixel Shield for Arduino

These are special versions of the app that have the same code as the corresponding standard versions, but have different settings so that they will work well with the **Wixel Shield for Arduino** [<https://www.pololu.com/product/2500>]. The default `baud_rate` was changed to 115200, which is the baud rate used by the **Arduino Uno's** [<https://www.pololu.com/product/2191>] bootloader. All the pin assignment parameters were set to -1 (disabled) except `arduino_DTR_pin`, which was left at 0 (P0\_0). The `framing_error_ms` parameter was set to 5. The only parameters of these apps that can be modified by the user are the `radio_channel` parameter and `baud_rate` parameter. For more information about configuring this version, please see the **Section 2.c** of the **Wixel Shield User's Guide** [<https://www.pololu.com/docs/0J47>].

- **Wireless Serial App (version 1.3) configured for the Wixel Shield for Arduino** [[https://www.pololu.com/file/download/wireless-serial-v1.3-shield.wx1?file\\_id=0J485](https://www.pololu.com/file/download/wireless-serial-v1.3-shield.wx1?file_id=0J485)] (25k wxl)

### 9.c. USB-to-Serial App

#### Overview

This app allows you to turn a Wixel into a USB-to-TTL serial adapter capable of baud rates up to 350,000 bps. While this app does not use the radio, it has more features than the USB-to-UART mode of the Wireless Serial App (see **Section 9.b**).

#### Installation Instructions

Download the **USB-to-Serial App (v1.0)** [[https://www.pololu.com/file/download/usb-serial-v1.0.wx1?file\\_id=0J464](https://www.pololu.com/file/download/usb-serial-v1.0.wx1?file_id=0J464)] (13k wx1). Open it with the Wixel Configuration Utility and write it to a Wixel. See **Section 4** for more information on how this is done.

#### Pinout

Pin		Function
P1_0	$\overline{\text{DTR}}$	general purpose output pin controlled by computer
P1_1	$\overline{\text{RTS}}$	general purpose output pin controlled by computer
P1_2	$\overline{\text{DSR}}$	general purpose input pin reported to computer
P1_3	$\overline{\text{CD}}$	general purpose input pin reported to computer
P1_6	TX	transmits serial data from computer
P1_7	RX	receives data and sends it to the computer

#### Description

After you have loaded this app onto a Wixel, the Wixel will appear to the computer as Virtual COM Port (with USB product ID 0x2200). If you are using Windows, you should see an entry labeled “Wixel” in your Device Manager in the “Ports (COM & LPT)” category while the app is running. You can connect to this COM port using a terminal program in order to send and receive data on the TX and RX lines. Typical terminal programs will allow you to set the baud rate, parity type, and number of stop bits. Some terminal programs will allow you to use the control signals (DTR, RTS, DSR, and CD). For more information, on how to use a virtual COM port, see **Section 6**.

This app supports all integer baud rates between 23 and 350,000 bps.

This app supports all the different types of parity: None, Odd, Even, Mark and Space.

This app supports 1 stop bit or 2 stop bits mode.

The RX line has an internal pull-up resistor, so you can leave this line disconnected.

The  $\overline{\text{DSR}}$  and  $\overline{\text{CD}}$  input pins have internal pull-up resistors, so when they are disconnected they will read as high (logical 0).

The  $\overline{\text{DTR}}$  and  $\overline{\text{RTS}}$  output pins are designed for high current (see the information on P1\_0 and P1\_1 in **Section 1.a**).

The control signals are all inverted, which means that a logical 0 corresponds to a high voltage (3.3 V) and a logical 1 corresponds to a low voltage (0 V).



**Wixel programmable USB wireless module (fully assembled) with USB cable connected.**

This app will discard bytes received on the RX line that have framing errors or parity errors, and it will also throw out bytes if there is an RX buffer overrun. An RX buffer overrun should not happen if you are using a baud rate of 350,000 bps or less.

### Example Uses

- The TX line can be used to send commands to a microcontroller or other serial device.
- The RX line can be used to receive data from a microcontroller or other serial device.
- The DTR and RTS lines are general-purpose digital outputs that can be used to control something (such as an LED) from a computer.
- The DSR and CD lines are general-purpose digital inputs that can be connected to a sensor or other circuit and read from a computer.

### Caveats

- The CC2511's UARTs do not actually support 1.5 stop bits, so if you try to set the number of stop bits to 1.5, this app will use 1 stop bit instead.
- The CC2511's UARTs do not support having 2 stop bits very well, so if you set the number of stop bits to 2, this app may fail to detect framing errors that occur during the second stop bit. Also, the next byte received after the framing error occurred may be discarded even if that byte is valid. This problem only applies to receiving bytes on the RX line; this app has no problem transmitting bytes on the TX line with 2 stop bits.

**Caution:** The Wixel's I/O lines are **not** 5V tolerant. You must use level-shifters, diodes, or voltage dividers to connect the Wixel to outputs from 5V systems. Also, avoid drawing more current from an I/O line than it can provide (see the discussion of P1\_0 and P1\_1 in **Section 1.a**). Avoid connecting multiple output pins together.

The Wixel does **not** support the RS-232 voltage levels typically used by DB9 serial ports. The Wixel's I/O lines, including the RX and TX lines, operate on voltages between 0 and 3.3 V. To connect the Wixel to an RS-232 serial signal, you will need additional level-shifting and inverting hardware like the **Pololu 23201a serial adapter** [<https://www.pololu.com/product/126>] (RS-232 serial is inverted; the Wixel's serial interface expects non-inverted serial).

## 9.d. Serial ASCII-to-Binary App

### Overview

This app uses the Wixel's two UARTs to convert between ASCII characters and "binary" data with arbitrary bytes. This can be useful if you are programming a controller with a serial interface that is limited to only transmitting ASCII characters, but you want to control a device with a serial interface that requires you to send arbitrary bytes between 0x00 and 0xFF. This app can act as a translator between your controller and such a device.

### Installation Instructions

Download the **Serial ASCII-to-Binary App (v1.0)** [[https://www.pololu.com/file/download/serial-ascii-binary-v1.0.wx1?file\\_id=0J640](https://www.pololu.com/file/download/serial-ascii-binary-v1.0.wx1?file_id=0J640)] (17k wxl). Open it with the Wixel Configuration Utility, choose your parameters, and then write it to a Wixel. See **Section 4** for more information on how this is done.

## Pinout

Pin	Function	
P0_3	ASCII_TX	Serial output, transmits ASCII (0–3.3 V)
P0_2	ASCII_RX	Serial input, receives ASCII (0–3.3 V, not 5 V tolerant)
P1_6	BINARY_TX	Serial output, transmits arbitrary bytes (0–3.3 V)
P1_7	BINARY_RX	Serial input, receives arbitrary bytes (0–3.3 V, not 5 V tolerant)

### ASCII-to-Binary conversion

ASCII characters are received on the ASCII\_RX pin, converted into the appropriate bytes, and then transmitted on BINARY\_TX. If you want the Wixel to send a particular byte on the BINARY\_TX line, then you should send an ASCII 'H' character to the ASCII\_RX pin, followed by the two hex digits representing the byte. For example, if you want the Wixel to transmit the byte 0xFA on BINARY\_TX, send the three-byte ASCII string "HFA" to the ASCII\_RX line. This example can be described as:

ASCII string "HFA" → ASCII\_RX → ASCII-to-binary conversion → BINARY\_TX → byte 0xFA

The delimiting 'H' character can be omitted, but we recommend sending it at the beginning of each transmission to make sure the Wixel is in sync with the device transmitting the ASCII. For example, to send the two bytes 0xFA and 0x1C, you could send the five-byte ASCII string "HFA1C".

Uppercase and lowercase hex digits are both recognized. You do not need to send any newlines or other ending delimiters to the ASCII\_RX line. The Wixel transmits each byte as soon as the second hex digit is received.

### Binary-to-ASCII conversion

Arbitrary bytes are received on the BINARY\_RX pin and an ASCII representation of them is transmitted on BINARY\_TX. Whenever a byte is received on BINARY\_RX, the Wixel will transmit three bytes on the ASCII\_TX line: the delimiting character 'H' is transmitted first, followed by the two hex digits representing the byte. For the digits A–F, upper case is used. For example, if the Wixel receives 0xFB on BINARY\_RX, it will transmit the three-byte ASCII string "HFB" on ASCII\_TX. This example can be described as:

Byte 0xFB → BINARY\_RX → Binary-to-ASCII conversion → ASCII\_TX → ASCII string "HFB"

The Wixel does not ever omit the delimiting character 'H' when transmitting on the ASCII\_TX pin.

### Serial specifications

The serial interfaces of this app are non-inverted and they use 8 data bits with 1 stop bit. This is called 8-N-1. Any serial devices connected to the Wixel should use these same settings.

### Parameters

- `ascii_baud_rate`: The baud rate of the ASCII interface (ASCII\_RX and ASCII\_TX), in bits per second. The default value is 9600 bps. We recommend not exceeding 115200.
- `binary_baud_rate`: The baud rate of the binary interface (BINARY\_RX and BINARY\_TX), in bits per second. The default value is 9600 bps. We recommend not exceeding 115200.

## Caveats

- If data is received on the ASCII\_RX or BINARY\_RX pins too quickly, it could result in the internal buffers filling up and data loss. This app has 512 bytes of buffer space for the ASCII-to-binary conversion and 512 bytes of buffer space for the binary-to-ASCII conversion.

**Caution:** The Wixel's I/O lines are **not** 5V tolerant. You must use level-shifters, diodes, or voltage dividers to connect the Wixel to outputs from 5V systems. Also, avoid drawing more current from an I/O line than it can provide (see the discussion of maximum pin current in **Section 1.a**). Avoid connecting multiple output pins together.

The Wixel does **not** support the RS-232 voltage levels typically used by DB9 serial ports. The Wixel's I/O lines, including the RX and TX lines, operate on voltages between 0 and 3.3 V. To connect the Wixel to an RS-232 serial signal, you will need additional level-shifting and inverting hardware like the **Pololu 23201a serial adapter** [<https://www.pololu.com/product/126>] (RS-232 serial is inverted; the Wixel's serial interface expects non-inverted serial).

## Versions

- **Serial ASCII-to-Binary App v1.0** [[https://www.pololu.com/file/download/serial-ascii-binary-v1.0.wx1?file\\_id=0J640](https://www.pololu.com/file/download/serial-ascii-binary-v1.0.wx1?file_id=0J640)] (17k wxl), released 2013-06-06: Initial release.

## 9.e. Serial-to-I<sup>2</sup>C App

### Overview

This app turns a Wixel into a serial-to-I<sup>2</sup>C bridge, acting as a master controller on a single-master I<sup>2</sup>C bus. To perform I<sup>2</sup>C operations, another device can issue serial ASCII commands to the Wixel on its radio, UART, or USB interface.

**I<sup>2</sup>C** [<http://en.wikipedia.org/wiki/I2C>] is a two-wire interface that is commonly used for communications on peripherals like the **LSM303DLHC compass** [<https://www.pololu.com/product/2124>] and the **BMP085 pressure sensor** [<https://www.pololu.com/product/1646>]. The **official specification** [[https://www.pololu.com/file/download/UM10204.pdf?file\\_id=0J435](https://www.pololu.com/file/download/UM10204.pdf?file_id=0J435)] (371k pdf) for the I<sup>2</sup>C bus is published by NXP.

### Installation Instructions

Download the **Serial-to-I<sup>2</sup>C App (v1.0)** [[https://www.pololu.com/file/download/serial-i2c-v1.0.wx1?file\\_id=0J480](https://www.pololu.com/file/download/serial-i2c-v1.0.wx1?file_id=0J480)] (26k wxl). Open it with the Wixel Configuration Utility, choose your parameters, and then write it to a Wixel. See **Section 4** for more information on how this is done.

### Default Pinout

Pin	Function	
P1_0	SCL	I <sup>2</sup> C clock (0–3.3 V)
P1_1	SDA	I <sup>2</sup> C data (0–3.3 V)
P1_6	TX	transmits serial data (0–3.3 V)
P1_7	RX	receives serial data (0–3.3 V)



## Description

This device appears to the USB host as a Virtual COM Port (with USB product ID 0x2200). If you are using Windows, you should see an entry labeled “Wixel” in your Device Manager in the “Ports (COM & LPT)” category while the app is running.

There are three basic bridge modes that can be selected:

0. **Radio-to-I<sup>2</sup>C**: Serial commands from the radio are used to control I<sup>2</sup>C transfers. Data read from the I<sup>2</sup>C slave is returned to the radio. Another Wixel running the standard **Wireless Serial app** [<https://www.pololu.com/docs/0J46/9.b>] can be used to communicate with this Wixel wirelessly.
1. **UART-to-I<sup>2</sup>C**: Serial commands from the UART's RX line are used to control I<sup>2</sup>C transfers. Data read from the I<sup>2</sup>C slave is returned to the UART's TX line.
2. **USB-to-I<sup>2</sup>C**: Serial commands from the USB virtual COM port are used to control I<sup>2</sup>C transfers. Data read from the I<sup>2</sup>C slave is returned to the virtual COM port.

You can select which bridge mode you want to use by setting the **bridge\_mode** parameter to the appropriate number (from the list above). The default bridge mode is Radio-to-I<sup>2</sup>C (0).

The UART RX pin has an internal 20 kΩ pull-up resistor.

The I<sup>2</sup>C lines (SCL and SDA) are on P1\_0 and P1\_1, respectively, by default; these can be changed with the **I2C\_SCL\_pin** and **I2C\_SDA\_pin** parameters. They do not have pull-ups enabled, so external pull-ups must be added to form a bus that conforms to the I<sup>2</sup>C specification. (Some carrier boards for I<sup>2</sup>C devices include pull-ups on these lines.)

The I<sup>2</sup>C bus frequency is 100 kHz by default, which can be changed with the **I2C\_freq\_kHz** parameter. This app does not support I<sup>2</sup>C arbitration, which means it cannot be used on multi-master I<sup>2</sup>C buses.

## Serial Commands

This app listens on the selected serial interface for commands and performs the corresponding I<sup>2</sup>C transactions. The command format is similar to the one used by the **NXP SC181M700 Master I<sup>2</sup>C-bus controller with UART interface** [[http://www.nxp.com/products/interface\\_and\\_connectivity/bridges/uart\\_to\\_i2c\\_master\\_gpio\\_bridges/SC181M700IPW.html](http://www.nxp.com/products/interface_and_connectivity/bridges/uart_to_i2c_master_gpio_bridges/SC181M700IPW.html)]. Three commands, in the form of ASCII characters, are recognized:

Command	Description
'S'	I <sup>2</sup> C START
'P'	I <sup>2</sup> C STOP
'E'	Get Errors

The general format for a command sequence begins with a START command ('S'), followed by a slave device address, the number of data bytes to be written or read, the data to be written (if a write is being done), and finally a STOP command ('P'). If a read is being done, the data read from the slave device will be returned on the serial interface. The least significant bit of the slave device address (the data direction bit) indicates whether the operation is a write (0) or a read (1). A repeated START condition can be generated by issuing another START command without sending a STOP command.

For example, to write the value 0x2E to register 0xF4 on a slave device with the write address 0xEE, the following sequence of bytes could be sent to the Wixel:

```
'S', 0xEE, 2, 0xF4, 0x2E, 'P'
```

To read a two-byte value from register 0xF6 on the same device, whose read address would be 0xEF, the following sequence could be issued (the second 'S' generates a repeated START):

```
'S', 0xEE, 1, 0xF6, 'S', 0xEF, 2, 'P'
```

The Wixel would respond with the two data bytes read from the slave.

Any invalid or unrecognized command is ignored and causes the Invalid Command error bit to be set.

To prevent an unfinished command sequence from leaving the I<sup>2</sup>C bus in an unusual state, this app will time out and reset the bus if a byte is not received on the serial interface within 500 ms of the last byte. After this happens, the Command Timeout error bit will be set, and a new command sequence must be initiated with a START command. The command timeout delay can be changed with the `cmd_timeout_ms` parameter; a value of 0 disables this timeout.

If the Wixel receives a Get Errors command ('E'), it will respond with a single byte containing the status of several error conditions. This command can be issued any time the app is not expecting a slave address or data byte.

When an error occurs, the corresponding bit in the error byte is set and remains set until the errors are read with the Get Errors command, after which it is cleared internally. The following table shows the error condition that corresponds to each bit:

Bit	Error	Description
0 (LSB)	I <sup>2</sup> C NACK on Address	A NACK was received on the I <sup>2</sup> C bus after a slave device address was transmitted.
1	I <sup>2</sup> C NACK on Data	A NACK was received on the I <sup>2</sup> C bus after a data byte was transmitted.
2	I <sup>2</sup> C Timeout	The SCL line stayed low for too long (possibly because a slave device was holding it low) and the I <sup>2</sup> C bus was reset. The allowed delay until this timeout occurs is 10 ms by default and can be changed with the <code>I2C_timeout_ms</code> parameter.
3	Invalid Command	An invalid command byte was received on the serial interface.
4	Command Timeout	The next byte of an unfinished command sequence took too long to be received on the serial interface. The timeout is 500 ms by default and can be changed or disabled with the <code>cmd_timeout_ms</code> parameter.
5	UART Overflow	The UART's receive buffer is full.
6	UART Framing Error	A framing error occurred on the UART.

### Indicator LEDs

The **green** LED behaves as described in **Section 1.a**, and also flickers when there is data transferred over USB.

The **yellow** LED is on when VIN power is detected.

The **red** LED indicates an error condition when lit; it can be reset by issuing a Get Errors command (described above).

## General Parameters

- **bridge\_mode:** Selects the bridge mode (0–2, see list above). The default is 0.
- **baud\_rate:** The baud rate to use for the UART, in bits per second. The default is 9600. We recommend not exceeding 115200. This parameter has no effect on serial communication over the virtual COM port (USB).
- **I2C\_freq\_kHz:** The clock frequency of the I<sup>2</sup>C bus, in kilohertz. The default is 100. Common I<sup>2</sup>C speeds are 10 kHz (low speed), 100 kHz (standard), and 400 kHz (high speed). The range of possible frequencies is 2-500 kHz; because of rounding inaccuracies and timing constraints, the actual frequency might be lower than the selected frequency, but it is guaranteed never to be higher.
- **I2C\_timeout\_ms:** The allowed delay, in milliseconds, before a low SCL line causes an I<sup>2</sup>C bus timeout. This resets the bus and sets the I<sup>2</sup>C Timeout error bit. The default is 10.
- **cmd\_timeout\_ms:** The allowed delay, in milliseconds, before failure to receive the next byte of a command sequence causes a command timeout. This resets the I<sup>2</sup>C bus and sets the Command Timeout error bit. The default is 500. A value of 0 disables this timeout.
- **radio\_channel:** The channel number is from 0 to 255 and determines which frequency to broadcast on. The default is 128. Wixels must be on the same channel to communicate with each other. To avoid interference, Wixels that aren't supposed to talk to each other should be at least 2 channels away from each other. For example, you could have one pair of Wixels on channel 128 and another pair on 130.

## Pin Assignment Parameters

The following parameters can be used to reassign the I<sup>2</sup>C lines to different pins on the Wixel. The value of each parameter must be the number of an unused pin on the Wixel. The number can be computed by multiplying the first digit in the pin name by 10 and adding it to the second digit in the pin name. For example, if you wanted to assign the SCL pin to P1\_2, you would set **I2C\_SCL\_pin** to 12.

- **I2C\_SCL\_pin:** The pin assignment for the I<sup>2</sup>C SCL (clock) line. The default is 10 (P1\_0).
- **I2C\_SDA\_pin:** The pin assignment for the I<sup>2</sup>C SDA (data) line. The default is 11 (P1\_1).

## Caveats

Data will be lost if the Wixel receives commands on the UART's RX line faster than they can be processed on the I<sup>2</sup>C bus. If you have trouble, try reducing the amount of data sent to the RX line by lowering the baud rate or adding delays to your microcontroller's code. Using the Get Errors command and checking the UART Overflow error bit is a good way to detect this problem.

**Caution:** The Wixel's I/O lines are **not** 5V tolerant. You must use level-shifters, diodes, or voltage dividers to connect the Wixel to outputs from 5V systems. Also, avoid drawing more current from an I/O line than it can provide (see the discussion of P1\_0 and P1\_1 in **Section 1.a**). Avoid connecting multiple output pins together.

The Wixel does **not** support the RS-232 voltage levels typically used by DB9 serial ports. The Wixel's I/O lines, including the RX and TX lines, operate on voltages between 0 and 3.3 V. To connect the Wixel to an RS-232 serial signal, you will need additional level-shifting and inverting hardware like the **Pololu 23201a serial adapter** [<https://www.pololu.com/product/126>] (RS-232 serial is inverted; the Wixel's serial interface expects non-inverted serial).

## Versions

- **Serial-to-I<sup>2</sup>C App v1.0** [[https://www.pololu.com/file/download/serial-i2c-v1.0.wx1?file\\_id=0J480](https://www.pololu.com/file/download/serial-i2c-v1.0.wx1?file_id=0J480)] (26k wx1), released 2011-05-03: Initial release.

## 9.f. I/O Repeater App

### Overview

This app allows you to wirelessly extend the reach of your microcontroller's I/O lines up to 50 feet using two or more Wixels. An input pin on one Wixel can be mapped to an output pin on another Wixel. When the input pin reads high, the output pin will be driven high (3.3 V) and when the input pin reads low, the output pin will be driven low (0 V). Each Wixel can have up to 15 input pins, 15 output pins, or a mixture of input and output pins. Each input pin can map to one or more output pins on one or more Wixels.

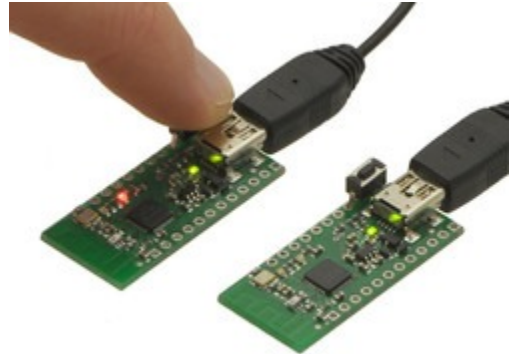

### Installation Instructions

Download the **I/O Repeater App (v1.3)** [[https://www.pololu.com/file/download/io-repeater-v1.3.wx1?file\\_id=0J562](https://www.pololu.com/file/download/io-repeater-v1.3.wx1?file_id=0J562)] (22k wx1). Open it with the Wixel Configuration Utility, choose your settings, and write it to two or more Wixels. See **Section 4** for more information on how this is done.

### Description

The following 15 pins on each Wixel can be used as inputs or outputs (or be disabled):

- All the pins on Port 0: P0\_0, P0\_1, P0\_2, P0\_3, P0\_4, P0\_5.
- All the pins on Port 1: P1\_0, P1\_1, P1\_2, P1\_3, P1\_4, P1\_5, P1\_6, P1\_7.
- Pin P2\_1 (the red LED pin).

The behavior of each pin is determined by its *link ID*, which is a parameter that you can set individually for each pin on each Wixel using the Wixel Configuration Utility. A link ID of 0 means the pin will be disabled (it will be an input but its input value will not have any effect). A negative link ID between -1 and -127 means that the pin will be a digital input and its value will be transmitted over the radio. A positive link ID between 1 and 127 means that the pin will be a digital output and its output value will be determined by the input value of the pin with the opposite (negated) link ID on another Wixel. For example, if the P1\_3 pin on one Wixel has a link ID of -13, then it will be a digital input and its value will be reflected on all the output pins that have a link ID of 13 on all the other Wixels. Input pins do **not** have any effect on output pins that are on the same Wixel.

If a Wixel is running this app and has one or more pins configured to be inputs, then it will transmit a single radio packet every 7–10 ms that contains input values and link IDs of all of its inputs. Any other Wixel that successfully receives this packet will process it and use it to update the state of its output pins.

This app will work with more than two Wixels on the same radio channel. In that case, make sure that you do not have multiple input pins on different Wixels with the same link ID: otherwise, the corresponding output pin(s) will change state unpredictably whenever there is a conflict between the different input pins. It is OK to have multiple *output* pins with the same link ID.

Every pin configured as an input has an internal 20 kΩ pull-up resistor except P1\_0 and P1\_1, which float when they are inputs. This means that if you leave the input pin disconnected, it will be pulled high by default.

Each output pin will drive low (0 V) by default before any radio packets are received that change its state.

After you have loaded this app onto a Wixel, the Wixel will appear to the computer as Virtual COM Port (with USB product ID 0x2200). If you are using Windows, you should see an entry labeled “Wixel” in your Device Manager in the “Ports (COM & LPT)” category while this app is running. You can not send or receive data on this COM port. Its only purpose is to let the Wixel Configuration Utility easily get the Wixel into bootloader mode.

### Parameters

- **radio\_channel:** The channel number is from 0 to 255 and determines which frequency to broadcast on. The default is 128. Wixels must be on the same channel to communicate with each other. To avoid interference, Wixels that aren't supposed to talk to each other should be at least 2 channels away from each other. For example, you could have one pair of Wixels on channel 128 and another pair on 130.
- **Pm\_n\_link:** The link ID of pin Pm\_n where *m* is the port number (0–2) and *n* is the pin number (0–7).

### Default Settings

The default settings are:

Pin	Link ID	Function
P0_0	-1	Input with pull-up resistor.
P2_1 (red LED pin)	1	Output linked to P0_0 on the other Wixel.

Therefore, if you load this app onto two Wixels using the default settings, they should behave as follows: If nothing is connected to either Wixel's P0\_0 line, the red LEDs on both Wixels will be on. If you connect the P0\_0 line of one Wixel to GND using a wire, then you should see the red LED on the other Wixel turn off. This demonstrates the basic operation of the app.

### Example Uses

- A Wixel output pin can be used to control an LED. Be sure to use an appropriate current-limiting resistor in series with the LED (e.g. 1 kΩ).
- A Wixel input pin can be used to read the state of a button or switch. Connect the button or switch between the input pin and GND, so that when the switch is open the pin will read high, and when the switch is closed the pin will read low.
- A Wixel output pin can be connected to an input pin on another microcontroller.
- A Wixel input pin can be connected to an output pin on another microcontroller. The output must not drive to a voltage higher than 3.3 V. If your microcontroller is running at 5 V you could get around this by using a diode or putting your output pin into open-collector mode (never drive high).

### Caveats

- A change on an input pin will usually be reflected on the corresponding output pin(s) within 10–100 ms, but every radio packet has a chance of being lost so there is no guaranteed latency. Therefore, this app is only suitable for very low-speed digital signals such as the signal from a pushbutton or the signal used to control an LED. This app is not suitable for PWM or RC servo signals.
- This app uses digital I/O which means that every reading is transmitted as a 0 or 1. This app does not support analog voltages.

**Caution:** The Wixel's I/O lines are **not** 5V tolerant. You must use level-shifters, diodes, or voltage dividers to connect the Wixel to outputs from 5V systems. Also, avoid drawing more current from an I/O line than it can provide (see the discussion of P1\_0 and P1\_1 in **Section 1.a**). Avoid connecting multiple output pins together.

## Versions

- **I/O Repeater App v1.3** [[https://www.pololu.com/file/download/io-repeater-v1.3.wx1?file\\_id=0J562](https://www.pololu.com/file/download/io-repeater-v1.3.wx1?file_id=0J562)] (22k wx1), released 2012-07-03: Adds randomness to the radio packet transmission timing to prevent two transmitting Wixels from being synchronized if they start up at the same time.
- **I/O Repeater App v1.1** [[https://www.pololu.com/file/download/io-repeater-v1.1.wx1?file\\_id=0J500](https://www.pololu.com/file/download/io-repeater-v1.1.wx1?file_id=0J500)] (20k wx1), released 2011-07-26: Fixes a bug in v1.0 which prevented P1\_6 and P1\_7 from being used as outputs.
- **I/O Repeater App v1.0** [[https://www.pololu.com/file/download/io-repeater-v1.0.wx1?file\\_id=0J465](https://www.pololu.com/file/download/io-repeater-v1.0.wx1?file_id=0J465)] (18k wx1), released 2011-03-25: Initial release.

## 9.g. Joystick App

### Overview

This app allows a Wixel connected to a computer to be used as a joystick. Readings from the Wixel's analog and digital input pins can represent up to six analog axes and 16 digital buttons or switches. The Wixel appears to the computer as a standard USB Human Interface Device (HID); after the Wixel has been configured, no driver installation is necessary to use the joystick. With a Wixel running the Joystick App, you can easily build a custom USB input device or convert an existing device into a USB peripheral, as **this sample project** [<https://www.pololu.com/docs/0J59>] shows.



**This converted Tandy Deluxe Joystick is now usable as a USB Human Interface Device.**

### Default Pinout

Wixel pin	Input type	Joystick function
P0_0	Analog	X axis
P0_1		Y axis
P0_2		Z axis
P0_3		Rx axis
P0_4		Ry axis
P0_5		Rz axis
P1_2	Digital	Button 1
P1_3		Button 2
P1_4		Button 3
P1_5		Button 4
P1_6		Button 5
P1_7		Button 6

### Connecting Buttons and Potentiometers

The diagrams below show examples of how buttons, switches, and potentiometers can be connected to the Wixel for use with the Joystick App. For a more comprehensive tutorial on wiring these components to build a USB input device with a Wixel, see our **USB Wixel Joystick sample project** [<https://www.pololu.com/docs/0J59>].

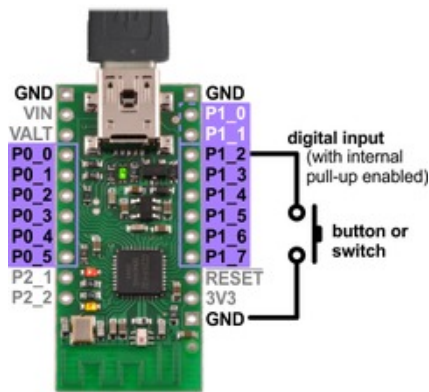

Note: P1\_0 and P1\_1 do not have internal pull-ups/pull-downs, so external resistors are required when using switches on these pins.

**Diagram for connecting a button or switch to the Wixel for use with the Joystick App.**

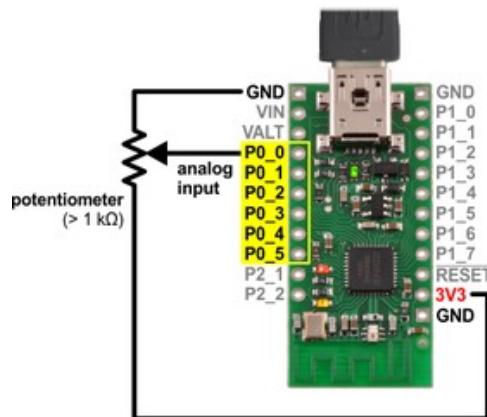

**Diagram for connecting a potentiometer to the Wixel for use with the Joystick App.**

### Wixel Configuration

Download the **Joystick App (v1.0)** [[https://www.pololu.com/file/download/joystick-v1.0.wx1?file\\_id=0J670](https://www.pololu.com/file/download/joystick-v1.0.wx1?file_id=0J670)] (33k wxl). Open it with the Wixel Configuration Utility, set any parameters you want to change from the default values, and then write

the app to a Wixel. (See **Section 4** for more information on how this is done.) The Wixel should now appear to your computer as a Human Interface Device.

If you are using Windows, there should be a new entry called “HID-compliant game controller” in your Device Manager in the “Human Interface Devices” section. The Wixel will also show up as a keyboard and a mouse, but it does not use those interfaces. To test the joystick functions, you can use the Game Controllers applet in the Control Panel, where you should see a “Wixel Joystick” entry. Selecting this entry and clicking the Properties button will display a dialog that shows the state of the joystick’s axes and buttons.

On Linux, the joystick should be represented by a new device node with a name like `/dev/input/js0`. You can test the joystick with a program such as `jstest` or `jstest-gtk`.



The Wixel Configuration Utility does not detect Wixels with USB HID interfaces. Therefore, if you need to reconfigure your Wixel, you will need to manually get it into bootloader mode (set pin P2\_2 high and reset – although this app monitors P2\_2 all the time and enters the bootloader if it goes high, so the reset is not strictly necessary).

This app’s parameters (detailed below) are used to configure how the Wixel’s inputs map to joystick functions. By default, the six analog inputs P0\_0 through P0\_5 are mapped to six analog joystick axes, and the six digital inputs P1\_2 through P1\_7 are mapped to six joystick buttons. Pull-ups are enabled for the buttons, which are configured as inverted inputs (so the Wixel interprets a logic low as a button press). If you don’t need all of the joystick axes, some or all of them can be disabled and the analog pins can be used as digital inputs for additional buttons instead.

### Parameters

- **buttonB\_pin:** The digital input pin that represents a joystick button; for example, a value of 12 selects the P1\_2 pin. A value of -1 disables the button.
- **buttonB\_invert:** Set to 0 for a non-inverted input: a logic high on the pin indicates a button press. Set to 1 for an inverted input: a logic low on the pin indicates a button press. The default is 1 (inverted).
- **axis\_channel:** The analog input (ADC channel) that represents a joystick axis. A value of -1 disables the axis.
- **axis\_invert:** Set to 0 for a non-inverted axis: the axis position is proportional to the input voltage. Set to 1 for an inverted axis: the axis position is inversely proportional to the input voltage. The default is 0 (non-inverted).
- **PM\_N\_pull\_enable:** Enables (1) or disables (0) the internal pull-up or pull-down resistor on the corresponding pin. (Note that P1\_0 and P1\_1 do not have pull-ups/pull-downs.) The direction the pin is pulled is determined by the `portM_pull_type` parameter for Port *M*. The default is 0 (disabled) for Port 0, to avoid interfering with analog readings, and 1 (enabled) for Port 1.
- **portM\_pull\_type:** Determines whether a pin on Port *M* is pulled down (0) or up (1) when the pin’s `PM_N_pull_enable` parameter is set. The default is 1 (high).

### Versions

- **Joystick App v1.0** [[https://www.pololu.com/file/download/joystick-v1.0.wx1?file\\_id=0J670](https://www.pololu.com/file/download/joystick-v1.0.wx1?file_id=0J670)] (33k wxl), released 2013-08-12: Initial release.



## 9.h. Wireless Tilt Mouse App

### Overview

This app allows you to make a wireless tilt mouse for your computer. By tilting the mouse, you can control the position of the mouse cursor. The mouse also supports two buttons for clicking.

This app requires two Wixels: a transmitter and a receiver. The transmitter Wixel detects a tilt using an accelerometer and wirelessly transmits that information to the receiver Wixel, which relays it to the computer as mouse movements. The receiver appears to the computer as a standard USB Human Interface Device (HID); after the Wixels have been configured, no driver installation is necessary to use the mouse.

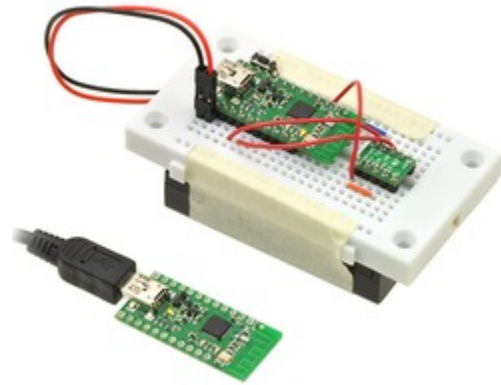

**Wireless tilt mouse made with two Wixels and an accelerometer.**

### Parts Needed

There are many different ways to build this project. Here are the parts we used:

- **Wixel Pair (Fully Assembled) + USB Cable** [<http://www.pololu.com/catalog/product/1338>]
- **MMA7361L 3-Axis Accelerometer  $\pm 1.5/6g$**  [<http://www.pololu.com/catalog/product/1246>]
- **3-AAA Battery Holder, Enclosed with Switch** [<http://www.pololu.com/catalog/product/1147>] and 3 AAA batteries
- **270-Point Breadboard** [<http://www.pololu.com/catalog/product/350>]
- **Mini Pushbutton Switches** [<http://www.pololu.com/catalog/product/1400>]

You will need wires and connectors to make the electrical connections. We suggest our **jumper wire kits** [<http://www.pololu.com/catalog/category/29>] or **premium jumper wires** [<http://www.pololu.com/catalog/category/65>].

You will need a **soldering iron** [<http://www.pololu.com/catalog/category/5>] to solder the included header pins into the accelerometer.

The pushbuttons are optional, and any normally-open (NO) pushbutton or switch will work. If you want to have both a left mouse button and a right mouse button you should get two pushbuttons. Note that only one button (on P1\_2) is shown in the picture above.

### Pinout of Transmitter Wixel

Pin	Function
P0_1	analog input for vertical mouse speed
P0_2	analog input for horizontal mouse speed
P1_2	left mouse button input, internally pulled high
P1_7	right mouse button input, internally pulled high

### Wixel Configuration

Download the **Wireless Tilt Mouse App (v1.0)** [[https://www.pololu.com/file/download/wireless-tilt-mouse-v1.0.wx1?file\\_id=0J470](https://www.pololu.com/file/download/wireless-tilt-mouse-v1.0.wx1?file_id=0J470)] (26k wxl). Open it with the Wixel Configuration Utility, choose your settings, and write it to the transmitter Wixel. The transmitter Wixel should now appear to your computer as a USB virtual COM port (with USB product ID 0x2200). You can not send or receive data on this COM port. Its only purpose is to let the Wixel

Configuration Utility easily get the transmitter Wixel into bootloader mode when the transmitter Wixel is connected to the computer via USB.

Download the **Wireless Tilt Mouse Receiver App (v1.0)** [[https://www.pololu.com/file/download/wireless-tilt-mouse-receiver-v1.0.wx1?file\\_id=0J471](https://www.pololu.com/file/download/wireless-tilt-mouse-receiver-v1.0.wx1?file_id=0J471)] (15k wxl). Open it with the Wixel Configuration Utility, choose your settings, and write it to the receiver Wixel. The receiver Wixel should now appear to your computer as a Human Interface Device. If you are using Windows there should be a new entry entitled “HID-compliant mouse” in your Device Manager in the “Mice and other pointing devices” section. The receiver will also show up as a keyboard, but it does not use that interface.



The Wixel Configuration Utility does not detect Wixels with USB HID interfaces. Therefore, if you need to reconfigure your receiver Wixel, you will need to manually get it into bootloader mode (set pin P2\_2 high and reset – although this app monitors P2\_2 all the time and enters the bootloader if it goes high, so the reset is not strictly necessary).

## Assembly

With the battery pack switched off, connect power for the transmitter Wixel. The black wire from the battery pack should connect to a GND pin on the Wixel. The red wire from the battery pack should connect to VIN. To test the connection, turn on the battery pack: the transmitter Wixel's yellow LED should turn on. Remember to turn off the battery pack while you are making connections.

Connect the GND of the Wixel to the GND (ground) pin of the accelerometer. Connect power for the accelerometer. The MMA7361L accelerometer we used can run off of 3.3 V and draws relatively little current, so we powered it from the Wixel's 3V3 line by connecting 3V3 to the accelerometer's VDD.

Make any connections necessary to enable your accelerometer. For the MMA7361L, we connected  $\overline{\text{SLP}}$  to VDD.

Choose which axis of the accelerometer will control the mouse cursor's horizontal movement and connect its output to the transmitter Wixel's P0\_2 pin. If your accelerometer is oriented as shown in the picture above, you should use the Y axis.

Choose which axis of the accelerometer will control the mouse cursor's vertical movement and connect its output to the transmitter Wixel's P0\_1 pin. If your accelerometer is oriented as shown in the picture above, you should use the X axis.

Connect a normally-open (NO) pushbutton between the transmitter Wixel's P1\_2 pin and GND. This will be the left mouse button. The P1\_2 input line has an internal pull-up resistor, so the voltage on that line should be high (3.3 V) when the button is not pressed. When the button is pressed, the voltage should go low (0 V).

In the same manner, connect a pushbutton between the transmitter Wixel's P1\_7 pin and GND. This will be the right mouse button.

## Parameters

Both the transmitter and receiver app have a parameter called **radio\_channel**. The channel number is from 0 to 255 and determines which frequency to broadcast on. The default is 128. The transmitter and receiver must be on the same channel to talk to each other. To avoid interference, Wixels that aren't supposed to talk to each other should be at least 2 channels away from each other. For example, you could have one pair of Wixels on channel 128 and another pair on 130.

The transmitter app has additional parameters to configure the behavior of the mouse:

- **invert\_x**: Set to 1 to invert the horizontal movement of the mouse. Default is 0.
- **invert\_y**: Set to 1 to invert the vertical movement of the mouse. Default is 0.
- **speed**: A positive number that determines the speed of the mouse. Default is 100. This speed is linearly proportional to this number.

### Alternative Parts

You could replace the battery pack with a single 9 V battery and a step-down regulator that outputs voltage within the Wixel's 2.7–6.5 V operating range, such as our **step-down voltage regulator D24V3ALV** [<http://www.pololu.com/catalog/product/2101>], or you could use a 1- or 2-cell holder along with an appropriate step-up voltage regulator, such as our **5V boost regulator NCP1402** [<http://www.pololu.com/catalog/product/798>].

You could replace the accelerometer by any other **accelerometer** [<http://www.pololu.com/catalog/category/80>] whose outputs are equal to one half of the input voltage when the acceleration on the corresponding axis is 0.

### Mouse Speed Calculation

The mouse speed is calculated from the measured acceleration vector of the device. The acceleration vector normally points straight upwards and has a magnitude of 1 g due to the Earth's gravity. The Wixel measures the X and Y outputs from the accelerometer, which tell it the components of the device's acceleration vector in the plane of the accelerometer. The resulting two-dimensional vector is then multiplied by its own magnitude to achieve greater control at lower speeds. The vector is then multiplied by the speed parameter to convert it into a mouse speed which is reported wirelessly to the computer.

## 9.i. ShiftBrite App

### Overview

This app allows you to wirelessly control a chain of one or more **ShiftBrite** [<https://www.pololu.com/product/1222>] RGB LED modules at a distance of 50 feet or more from a PC. You will need two Wixels to set up the wireless link: one connected to the ShiftBrites, running the ShiftBrite app, and one connected to your PC with USB, running the Wireless Serial App (**Section 9.b**). Using a terminal or your own software, you can send a series of hex characters indicating the desired color for each module to the virtual COM port. The characters are transmitted wirelessly, received by the remote Wixel, decoded, and sent to the ShiftBrite chain, causing each module to light up with the specified color. Approximately 1000 color commands can be sent per second, allowing large displays or smooth animations.

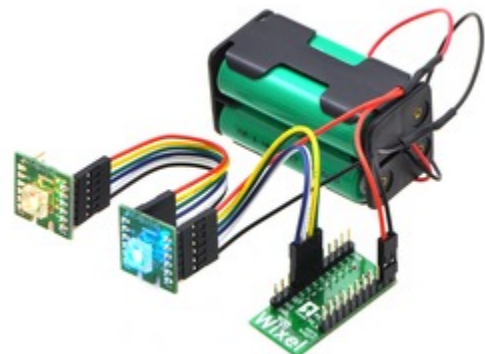

**A Wixel controlling a chain of ShiftBrites.**

The ShiftBrite App is also compatible with the **ShiftBar** [<https://www.pololu.com/product/1242>], which uses the same control electronics.

### Installation Instructions

Follow the instructions for the Wireless Serial App in **Section 9.b** to set up and test a basic wireless serial link between two Wixels, using the latest version of the Wireless Serial App. Download the **ShiftBrite App (v1.1)** [[https://www.pololu.com/file/download/shiftbrite-v1.1.wx1?file\\_id=0J469](https://www.pololu.com/file/download/shiftbrite-v1.1.wx1?file_id=0J469)] (20k wxl). Open it with the Wixel Configuration Utility, choose your settings, and write it to one of the Wixels. See **Section 4** for more information on how this is done.

## Connecting the Wixel to the ShiftBrite chain

The following connections should be made between the Wixel running the ShiftBrite App and the first ShiftBrite in the chain:

Wixel	ShiftBrite	Function
P1_4	EI	Enable
P1_5	CI	Clock
P1_6	DI	Data
P1_7	LI	Latch
GND	GND	Ground

Additionally, the Wixel and ShiftBrites may share the same VIN as long as the voltage requirements for both modules are satisfied. For initial testing, you may alternatively use VALT to power the ShiftBrites from USB (see **Section 5.a**).

## Using the ShiftBrite App

After making the correct connections and applying power, open a terminal program and connect to the COM port created by the Wixel running the Wireless Serial App. Type `ffffff`. As you type the characters, they will be echoed back to your terminal. Press Enter, and the first ShiftBrite in your chain will light up in white. Then type `ff0000` and press Enter; now the first ShiftBrite should be red, and the second should be white (if present).

To shift out multiple color commands at once, for example when you want to set the colors of the entire chain, type a series of single-color commands without pressing Enter, then press Enter once to apply them all.

## Parameters

- **radio\_channel:** The channel number is from 0 to 255 and determines which frequency to broadcast on. The default is 128. Wixels must be on the same channel to communicate with each other. To avoid interference, Wixels that aren't supposed to talk to each other should be at least 2 channels away from each other. For example, you could have one pair of Wixels on channel 128 and another pair on 130.
- **input\_bits:** The number of bits per channel that you would like to use to send color information. The allowed values are 1 to 16, and the default is 8, which corresponds to colors represented by 6-digit hex values. However, the ShiftBrite supports 10 bits of resolution, so choose a value of 10 to make use of its full dynamic range. In this case, you must send 9 digits to set a color. For example, `3ff3ff3ff` is the brightest possible white and `001000000` is the dimmest possible red. Other values for this parameter might be useful in special situations (e.g. 4 bits of resolution lets you specify a full color in three bytes, such as `ff00` for red, which allows for a higher update rate).
- **echo\_on:** Set to 0 to disable echoing of every character sent. While echoes are useful for debugging, you might want to disable them for the highest possible speed.

## Data Format

The data consists of a series of red, green, and blue (RGB) values, as ASCII hex strings. Each value contains from 1 to 4 characters, depending on the value of **input\_bits**, specifying a number from 0 to  $2^{\text{input\_bits}}-1$ . When a complete set of R, G, and B values has been received, the values are multiplied or divided by the appropriate factor to match the 10-bit ShiftBrite data format and shifted out to the ShiftBrite chain. An Enter character (ASCII 10 or 13) causes the Latch pin to be toggled, instantly setting each ShiftBrite to its new color.

## Tips

- The yellow LED is normally on, and flickers whenever data is received from the radio, which might be useful for debugging your wireless connection.
- You can use **wires with pre-crimped terminals** [<https://www.pololu.com/category/71/wires-with-pre-crimped-terminals>] and **crimp connector housings** [<https://www.pololu.com/category/70/crimp-connector-housings>] to make a custom cable between the Wixel and the ShiftBrite chain.

## Versions

- **Shiftbrite App v1.1** [[https://www.pololu.com/file/download/shiftbrite-v1.1.wx1?file\\_id=0J469](https://www.pololu.com/file/download/shiftbrite-v1.1.wx1?file_id=0J469)] (20k wxl), released 2011-04-06: Changed the yellow LED to be normally on, but flicker whenever data is received from the radio. This version is only compatible with Wireless Serial App v1.2 and later.
- **Shiftbrite App v1.0** [[https://www.pololu.com/file/download/shiftbrite-v1.0.wx1?file\\_id=0J466](https://www.pololu.com/file/download/shiftbrite-v1.0.wx1?file_id=0J466)] (18k wxl), released 2011-03-28: Initial release. In this version, the yellow LED starts off and turns on after the first Enter is received. This version is only compatible with Wireless Serial App versions 1.0 and 1.1.

## 10. Writing Your Own Wixel App

### 10.a. Getting Started in Windows

To get started developing your own Wixel Apps using Windows as the development platform, we recommend that you download and install the **Pololu Wixel Development Bundle: wixel-dev-bundle-120127.exe** [[https://www.pololu.com/file/download/wixel-dev-bundle-120127.exe?file\\_id=0J526](https://www.pololu.com/file/download/wixel-dev-bundle-120127.exe?file_id=0J526)] (10MB exe). This bundle contains four things:

- **Wixel SDK** [<http://pololu.github.io/wixel-sdk/>]: Contains source code (for libraries and applications) that will help you develop your own applications for the Wixel.
- **SDCC – Small Device C Compiler** [<http://sdcc.sourceforge.net/>]: A free compiler that is used to compile the code in the Wixel SDK.
- Pololu GNU Build Utilities: Windows versions of some open-source utilities that are required by the SDK.
- **Notepad++** [<http://notepad-plus-plus.org/>]: A free text editor which is convenient to use when editing Wixel code.

### 10.b. Compiling an Example App

After you have installed all the necessary software (either from the Wixel Development Bundle or from other sources), you should try compiling an example app and loading it onto a Wixel to make sure that your system is set up correctly.

#### Compiling Apps

Go to the folder where you installed the Wixel SDK (C:\wixel-sdk is the default) and run `make_all.bat`. If everything is installed correctly, the output of that batch file should look something like this:

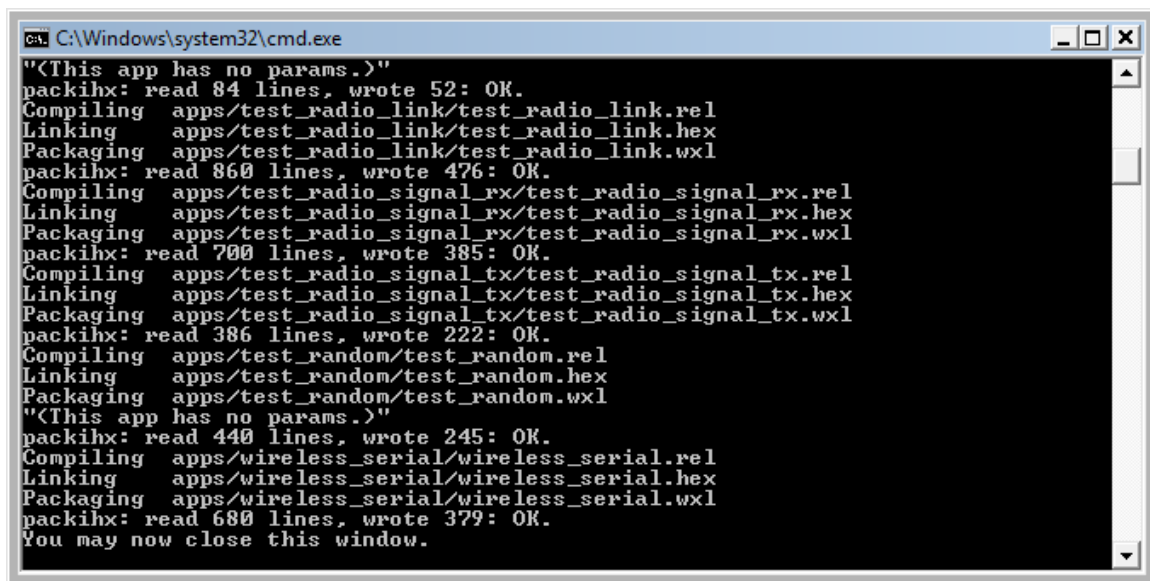

```
C:\Windows\system32\cmd.exe
"<This app has no params.>"
packihx: read 84 lines, wrote 52: OK.
Compiling apps/test_radio_link/test_radio_link.rel
Linking apps/test_radio_link/test_radio_link.hex
Packaging apps/test_radio_link/test_radio_link.wxl
packihx: read 860 lines, wrote 476: OK.
Compiling apps/test_radio_signal_rx/test_radio_signal_rx.rel
Linking apps/test_radio_signal_rx/test_radio_signal_rx.hex
Packaging apps/test_radio_signal_rx/test_radio_signal_rx.wxl
packihx: read 700 lines, wrote 385: OK.
Compiling apps/test_radio_signal_tx/test_radio_signal_tx.rel
Linking apps/test_radio_signal_tx/test_radio_signal_tx.hex
Packaging apps/test_radio_signal_tx/test_radio_signal_tx.wxl
packihx: read 386 lines, wrote 222: OK.
Compiling apps/test_random/test_random.rel
Linking apps/test_random/test_random.hex
Packaging apps/test_random/test_random.wxl
"<This app has no params.>"
packihx: read 440 lines, wrote 245: OK.
Compiling apps/wireless_serial/wireless_serial.rel
Linking apps/wireless_serial/wireless_serial.hex
Packaging apps/wireless_serial/wireless_serial.wxl
packihx: read 680 lines, wrote 379: OK.
You may now close this window.
```

You have now built all the apps in the Wixel SDK and all the libraries that they depend on. Every subfolder of the `apps` folder should now have a WXL file in it. This is a compiled app which can be loaded onto Wixels using the Wixel Configuration Utility or the Wixel Command-Line Utility (WixelCmd).



You might get the following error message from `make` in Windows:

```
make: Interrupt/Exception caught (code = 0xc00000fd, addr = 0x425073)
```

If you get this error, please run “`make -v`” at a Command Prompt and make sure that you are running **GNU Make 3.82-pololu2** [<https://github.com/pololu/make>]. This version of `make` is included in the latest Wixel Development Bundle (see **Section 10.a**). If the output from “`make -v`” shows some other version of `make` even after installing the Wixel Development Bundle, then you should remove that other version of `make` from your PATH or reorder your PATH so that version 3.82-pololu2 is used. You can edit your PATH environment variable from the Control Panel. See the **pololu/make wiki on GitHub** [<https://github.com/pololu/make/wiki>] for more information on this problem.

## Loading an App onto Wixels from the Command Line

While you are developing an app, it can be useful to have a way to load an app onto the target Wixel from the command line. You can do this with the Makefile: plug a Wixel into your computer, open up a command prompt, navigate to the `wixel-sdk` folder, and type `make load_example_blink_led`. This should compile the `example_blink_led` app (if it is out of date) and then invoke the Wixel Command-Line Utility (WixelCmd) in order to load the app onto all Wixels connected to your computer. The output should look something like this:

```
Administrator: Command Prompt
C:\wixel-sdk>make load_example_blink_led
wixelcmd write apps/example_blink_led/example_blink_led.wx1 -a
Sending command to get Wixel in to bootloader mode...
Waiting for Wixel to reconnect...
Erasing...
Progress: !!!!!!!!!!!!!!!!!!!!!!!!!!!!!!!!!!!!!!!!!!!!!!!!!!!!!!!!!!!!!!!!!!!!!!!!!!!!!!!!!!!!! Done.
Writing...
Progress: !!!!!!!!!!!!!!!!!!!!!!!!!!!!!!!!!!!!!!!!!!!!!!!!!!!!!!!!!!!!!!!!!!!!!!!!!!!!!!!!!!!!! Done.
C:\wixel-sdk>
```

The example blink LED application should be running now. The Wixel’s yellow LED should be off, and the red LED should be blinking. If that is the case, then congratulations! You have successfully compiled a program and loaded it onto the Wixel.

You can also specify settings at the command line. Try running this command:

```
make load_example_blink_led S="blink_period_ms=100"
```

You should now see the LED blinking 5 times faster than it was before. To specify multiple settings, put other settings inside the quotes and separate all settings with spaces.

## Opening an App with the Wixel Configuration Utility

You can also open the app in the Wixel Configuration Utility if you want to. Try running this command:

```
make open_example_blink_led
```

The Wixel Configuration Utility should start running and open the `example_blink_led` app.

## Creating Your Own Apps

Now that you know how to compile apps and quickly load them onto the Wixel to test them, you are ready to develop your own Wixel apps. You can either modify one of the existing apps in the SDK or create your own app. To create your own app, simply copy one of the existing app folders and change the name. You do **not** need to modify the Makefile when you create a new app; the Makefile will automatically detect the app as long as it is in the apps folder. When you are developing your app, you can use all of the commands above except you should replace “example\_blink\_led” with the name of your app (the name of the subfolder in the apps folder). For more information, including documentation of all the libraries in the Wixel SDK, see the **Wixel SDK Documentation** [<http://pololu.github.io/wixel-sdk/>].

### 10.c. Using the Eclipse IDE

You can develop Wixel applications using any text editor. If you use the free, open source Eclipse IDE, you can benefit from some of its advanced C/C++ editing features. The following is a tutorial on how to set up Eclipse for use with the Wixel SDK.

1. Install the Wixel SDK on your computer and compile an example app by following the instructions in the previous sections.

2. Download and install the **Eclipse IDE for C/C++ Developers** [<http://www.eclipse.org/downloads/>]. If you are a Windows user, we recommend that you download the **32-bit** version of Eclipse, even if you have a 64-bit operating system. You may need to install a Java Runtime Environment (JRE) before you can run Eclipse.

3. Run Eclipse. It will ask you to choose a workspace folder. Eclipse does not allow the workspace and project folders to be the same. Therefore, we recommend making a new folder called something like `eclipse_workspace`, moving the `wixel-sdk` folder inside of it, and choosing that new folder to be your Eclipse workspace location. By doing this, you can avoid having a large number of files in your workspace. You can switch your workspace location later if you need to.

4. After choosing your workspace folder, you will see a welcome screen that says “Welcome to the Eclipse IDE for C/C++ Developers” and has several circular icons on it. Click the icon with the yellow arrow in it to go to the Workbench.

5. From the **File** Menu, select **New > C Project**. This will open up a dialog entitled “C Project”.

6. For the Project name, enter `wixel-sdk`. The **Location** box should now show the correct location of your `wixel-sdk` folder. Eclipse will show a warning at the top of the window that says “Directory with specified name already exists.” (this is good).

7. Under **Project type**, select **Makefile project > Empty Project**. It does not matter what toolchain you select.

8. Click the **Finish** button to finish creating the `wixel-sdk` project.

9. Press **Ctrl+B** or select **Project > Build All** to build the project. This is equivalent to running `make all` in the `wixel-sdk` folder. You can see the build output by selecting the Console tab at the bottom or by going to **Window > Show View > Console**.

10. In the left-hand pane, you will see the “C/C++ Projects” or “Project Explorer” view. This view should display one entry entitled `wixel-sdk` which represents the project you just created. Double click on the project name to expand it and see all the folders and files inside it.

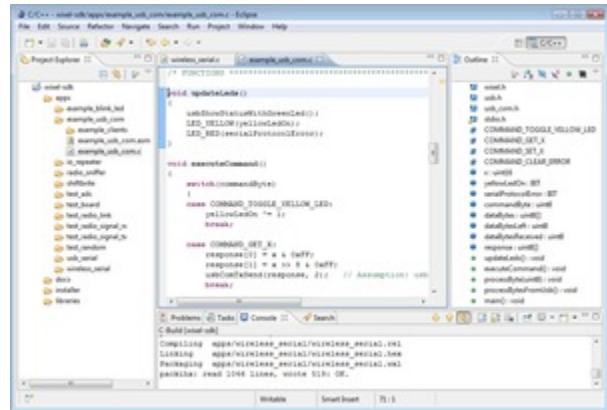

Using Eclipse with the Wixel SDK to develop Wixel applications.



11. Navigate to the `apps/example_blink_led` folder and double-click on `example_blink_led.c`. This will open the file in the center pane.
12. Make a small change to `example_blink_led.c`, such as removing a blank line or adding a comment. Save the file by pressing **Ctrl+S** or by selecting **File > Save**.
13. Press **Ctrl+B** or select **Project > Build All** to rebuild the project. When you do this, Eclipse runs `make` in the `wixel-sdk` folder, which builds all of the apps and the libraries they depend on. Once again, you can see the build output by selecting the Console tab at the bottom or by going to **Window > Show View > Console**. The Wixel SDK's Makefile should detect that `example_blink_led.c` has changed, so it should rebuild the app. The output in the Console view should look something like this:

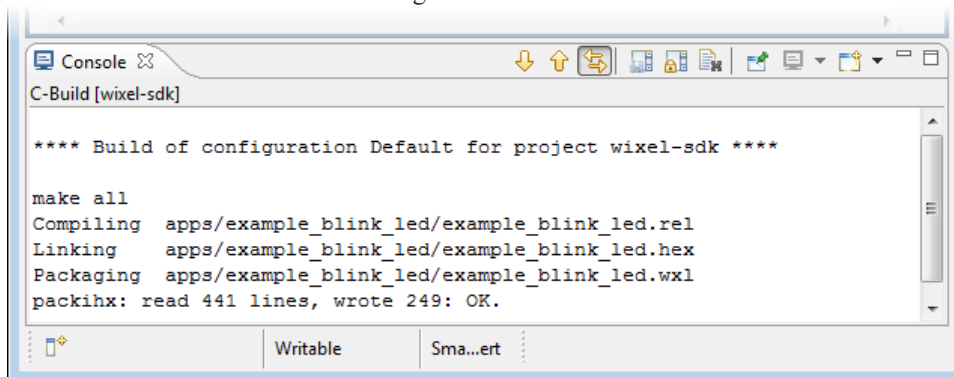

```

C-Build [wixel-sdk]

**** Build of configuration Default for project wixel-sdk ****

make all
Compiling  apps/example_blink_led/example_blink_led.rel
Linking    apps/example_blink_led/example_blink_led.hex
Packaging  apps/example_blink_led/example_blink_led.wxl
packihx: read 441 lines, wrote 249: OK.

```

14. Congratulations! You have made your first change to an app and recompiled it using the Eclipse IDE.
15. When you are ready to load the app onto a Wixel, open up a Command Prompt, navigate to the `wixel-sdk` directory, and run `make load_APPNAME` where `APPNAME` is the name of the app. We do not have a way of loading apps onto the Wixel that is integrated into Eclipse.

### Improving the configuration of Eclipse

1. In the **Project** menu, select **Properties**. Under **C/C++ General > Paths and Symbols > Includes**, click the **Add...** button. Enter the full path to SDCC's include directory. If you are on a 64-bit machine and SDCC is installed in the default location, this will be "`C:\Program Files (x86)\SDCC\include`". Check the "Add to all languages" box and click OK. This will allow Eclipse to find the headers provided by the compiler, such as `stdio.h`, which will reduce the number of warnings you see from Eclipse while developing apps.
2. In the **Window** menu, select **Preferences**. Under **C/C++ > Code Analysis**, uncheck the boxes for "Type cannot be resolved" and "Field cannot be resolved". We found that these two errors were not working correctly under Eclipse Indigo Service Release 1, and they will be caught by the compiler regardless of how you configure Eclipse.
3. In the **Window** menu, select **Preferences**. Under **General > Workspace**, check **Save automatically before build**. This makes Eclipse save your code automatically before building, so you do not have to remember to do that.

### Advanced Features of Eclipse

The attraction of using Eclipse is the large number of advanced C/C++ editing features it provides. Here are just a few of these features:

- Eclipse supports C syntax highlighting.
- If an error occurs during the build, you can double-click on the error from the Console or Problems view in order to jump directly to the line of code that has the problem.

- If you put your text cursor on a function name, variable name, preprocessor macro, or include directive, then you can quickly jump to the place where that item is defined by pressing F3 or by right-clicking and selecting **Open Declaration**.
- Pressing **Ctrl+Tab** inside a source (.c) file opens up the corresponding header (.h) file, and vice-versa. This is especially useful if you are writing a Wixel library.
- The Outline view shows all the variables and functions defined in the current file. You can click on one of them to quickly jump to its definition. You can even drag them within the Outline view to change their order in your file.
- If you put your cursor on a function name, you can see all the places where that function is called by typing **Ctrl+Alt+H** or right-clicking and selecting **Open Call Hierarchy**.
- Eclipse makes it easy to rename selected objects (variables, methods/functions, etc.) by automatically propagating the changes to other files in the project. You can access this feature by putting your cursor on a name and then right-clicking and selecting **Refactor > Rename...**
- Eclipse scans your files for comments containing “TODO”. These comments are aggregated in the Tasks view, and you can also easily find them in your current file by clicking on the little blue rectangles to the right of the vertical scroll bar. Each blue rectangle represents the location of a TODO item in your file.

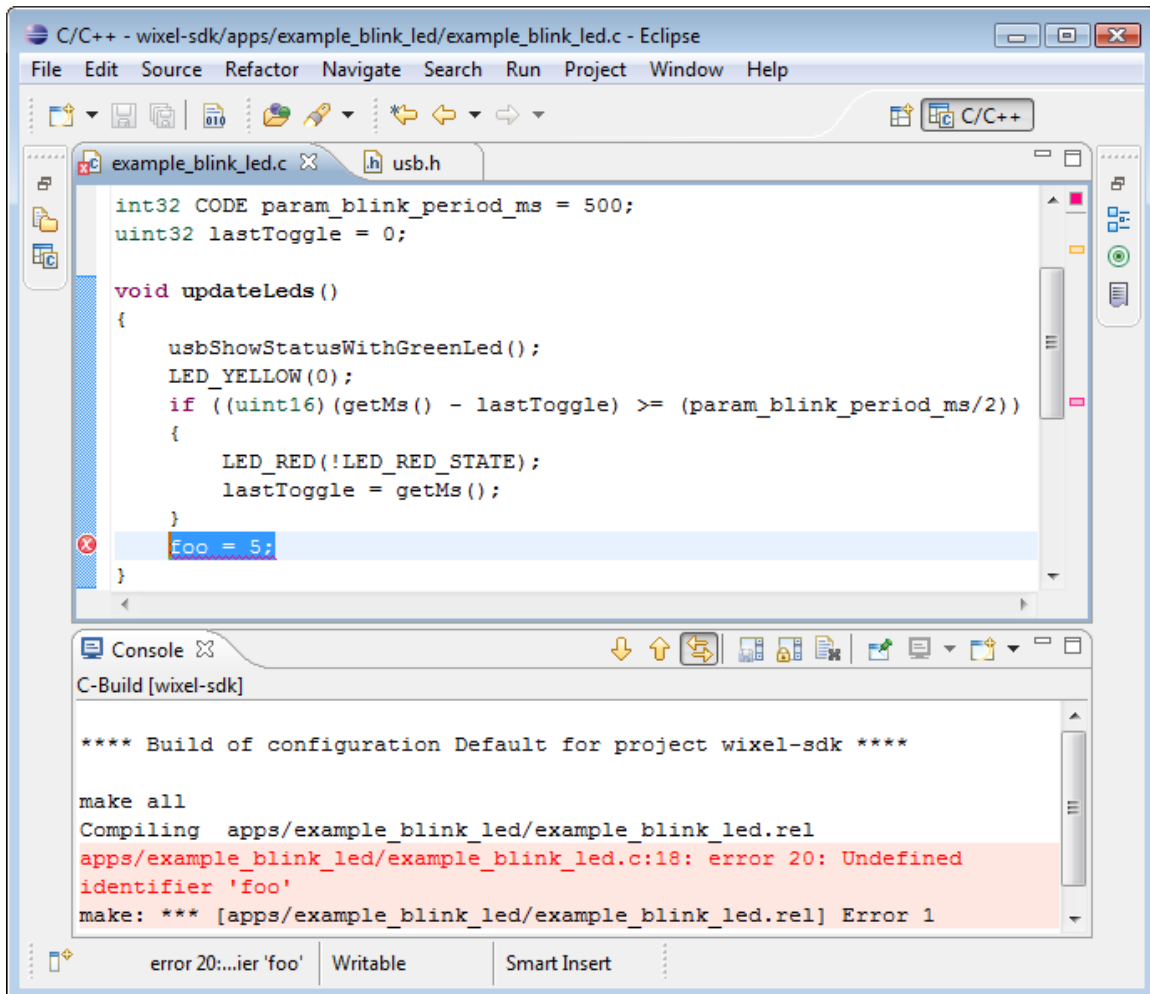

If there is an error during compilation in Eclipse, you can double-click on the error message to jump to the source of the error.

## Hiding Unused Features

By default, Eclipse has a large number of toolbar buttons, views (panes), and menu items that are not needed for developing Wixel applications. You can greatly simplify the user interface of Eclipse by hiding those items.

To hide unused toolbar and menu commands, select **Window > Customize Perspective...** This brings up the “Customize Perspective C/C++” window. Select the “Command Groups Availability” tab. By unchecking a command group in this tab, you can automatically remove all the commands in that group from the toolbars and the menus. The only useful command groups for developing Wixel applications are:

C/C++ Coding, C/C++ Editor Presentation, C/C++ Element Creation, C/C++ Navigation, C/C++ Open Actions, C/C++ Search, Editor Navigation, Editor Presentation, Keyboard Shortcuts, Open Files, Search

If you want further customization, you can use the “Tool Bar Visibility” and “Menu Visibility” tabs to show or hide individual commands.

### 10.d. Sharing Your App with the Wixel Community

#### Preparing your app for the community

Please make sure that you have set up the following sections in your WXL file:

- **description** – this should fully describe what your app does or link to a web site with a complete description. Since other people will be trying this on their Wixels, make sure to bring our attention to anything that may cause damage or incompatibility. Most importantly, *any IO ports used as outputs should be explicitly listed* in the description.
- **license** – this specifies the terms under which others may distribute copies or modifications of your app. We recommend and use the MIT license, which is simple and allows widespread use of your code. Note that if you have used the Wixel SDK to build your app, you need to include our license, though you may add your own restrictions if necessary. We recommend using the following template, which will make it easy for us to share your app or to include it in the Wixel SDK:

```
Copyright (c) 2011 <YOUR NAME>. Documentation for this app is available at:
```

```
http://<YOUR SITE>/
```

```
Copyright (c) 2011 Pololu Corporation. For more information, see
```

```
http://www.pololu.com/  
http://forum.pololu.com/
```

```
Permission is hereby granted, free of charge, to any person  
obtaining a copy of this software and associated documentation  
files (the "Software"), to deal in the Software without  
restriction, including without limitation the rights to use,  
copy, modify, merge, publish, distribute, sublicense, and/or sell  
copies of the Software, and to permit persons to whom the  
Software is furnished to do so, subject to the following  
conditions:
```

```
The above copyright notice and this permission notice shall be  
included in all copies or substantial portions of the Software.
```

```
THE SOFTWARE IS PROVIDED "AS IS", WITHOUT WARRANTY OF ANY KIND,  
EXPRESS OR IMPLIED, INCLUDING BUT NOT LIMITED TO THE WARRANTIES  
OF MERCHANTABILITY, FITNESS FOR A PARTICULAR PURPOSE AND  
NONINFRINGEMENT. IN NO EVENT SHALL THE AUTHORS OR COPYRIGHT  
HOLDERS BE LIABLE FOR ANY CLAIM, DAMAGES OR OTHER LIABILITY,  
WHETHER IN AN ACTION OF CONTRACT, TORT OR OTHERWISE, ARISING  
FROM, OUT OF OR IN CONNECTION WITH THE SOFTWARE OR THE USE OR  
OTHER DEALINGS IN THE SOFTWARE.
```

## Announcing your app on the Wixel forum

When you are ready for the community to try out a version of your app, you may announce it on **the Wixel forum** [<http://forum.pololu.com/viewforum.php?f=30>], attaching your WXL file. It is helpful to paste a copy of your **description** into your post so that we can see what your app is about before downloading it.

## Contributing your source code

Sharing your source code greatly increases the value of your app, since other members of the community will be able to adapt it to their own projects or learn from your code. You might also have made changes to the common sections of the Wixel SDK that you would like us to incorporate, or you might have discovered and want to share your fixes. For all of these reasons, we are maintaining the **Pololu Wixel SDK Repository on GitHub** [<http://github.com/pololu/wixel-sdk>] as a central location for sharing Wixel code. You can easily use this site to fork your own version of the Wixel SDK, show us what you are working on, submit changes, and so on.



GitHub uses the **Git Version Control System** [<http://git-scm.com/>] for tracking versions and branches of code, so we highly recommend learning how to use Git if you want to share your code with the Wixel community or even just to get the latest version for your own use. Teaching Git is beyond the scope of this User's Guide, but there are many good tutorials available on the web. For example, the **Git tutorial** [<http://help.github.com/set-up-git-redirect>] provided by GitHub will help you get started.

*For the rest of this section, we will assume that you are comfortable with Git.*

If you have been following the instructions in this document, your code is located within the `wixel-sdk` folder along with the rest of the Wixel SDK. This folder is actually a *clone* of our Git repository, which means that it includes history and version information as well as a link back to our repository (a *remote*), within the folder `.git`. As long as you have not modified the contents of `.git`, you should be able to use Git to *commit* your changes, *pull* updates from us, and *push* your changes to a public repository. To make sure that Git is working correctly, try typing the following command at the command prompt from within the `wixel-sdk` folder:

```
git log
```

This should display a list of recent commits in the repository. Alternatively, you can use the program `gitk` or you can use the “Show Log” command of TortoiseGit to view a much more detailed, graphical representation of the log. After reviewing the log, you can add and commit all of your new files:

```
git add <list of new files...>
git commit -a
```

Alternatively, you can use the “Commit...” command of TortoiseGit. Either way, you will be shown a list of new or modified files and prompted for a commit message. Please check this over carefully and write a good description of your changes, because it is very hard to change your commits after you make them public.

In some cases, you might want to start over with a fresh copy of the Wixel SDK, which you can make by typing

```
git clone -o pololu git://github.com/pololu/wixel-sdk.git
```

into a command prompt. At any time, you can download the latest updates from us and merge them into your code by typing the following command:

```
git pull pololu
```

Initially, you will commit your changes to your local repository, but when you are ready to publish them, you should set up your own repository on GitHub to make them accessible to the community. To do this, sign up for a GitHub account and fork our repository into a repository on your account. Please do this by clicking the “fork” button at the top of **our repository** [<http://github.com/pololu/wixel-sdk>] so that it will be connected within the GitHub system – this way we will see your changes and can easily incorporate them into the SDK. After making your fork, you can push all of the changes from your local repository to GitHub with

```
git remote add myrepo <GitHub URL>
git push myrepo
```

where `<GitHub URL>` is the SSH or HTTP URL shown on your GitHub page.

Finally, you will probably want to post a link to your GitHub repository on **the Wixel forum** [<http://forum.pololu.com/viewforum.php?f=30>]. This will help others find out about it and give you feedback on your contribution.

### 10.e. USB Configurations Recognized by the Wixel Configuration Software

The Wixel Configuration Utility and the Wixel Command-Line Utility can currently only recognize certain Wixel apps. If your app is not recognized, then users of your app will not easily be able to reconfigure it after they have loaded it onto their Wixel (they will have to get their Wixel into bootloader mode manually).

To be recognized, your app must implement a particular USB interface. Specifically, it must implement a USB CDC ACM virtual COM port with vendor ID 0x1FFB and product ID 0x2200. When the USB host sends a command to your app that sets the baud rate to 333, your app should enter bootloader mode. Your app should work with the `wixel_serial.inf` driver which is installed along with the other Windows software (see **Section 3.a**). The easiest way to write an app that meets these requirements is to use the `usb_cdc_acm.lib` library in the Wixel SDK.

In the future we will add support for other types of USB interfaces if there is a need for it. Please **contact us** [<https://www.pololu.com/contact>] if you would like to use other types of interfaces in your apps.

### 10.f. Wixel App File Format

For the purpose of loading a compiled program onto a Wixel, the Wixel Configuration Utility and the Wixel Command-Line Utility (WixelCmd) accept two file formats: Intel HEX (.hex) and Wixel App (.wxl). The **Intel HEX (.hex)** file format is an industry standard, and can be produced by most toolchains. The **Wixel App (.wxl)** file format is a simple format created by Pololu that includes an Intel HEX file inside it along with important metadata, such as the names and addresses of user-configurable parameters. The Wixel App file format is designed to be extensible and easy to generate.

The Wixel App file is plain text: every byte is an ASCII-encoded character. The allowed ASCII codes are 0x20 through 0x7F and also 0x09 (tab), 0xA (new line, “\n”), and 0xD (carriage return, “\r”). The bytes in a Wixel App file are divided into *lines*. Line endings can be encoded with any of the following byte sequences: “\r\n” (0xD, 0xA), “\r” (0xD), or “\n” (0xA).

The first line must be “Pololu Wixel Application - www.pololu.com”. This line explains the purpose of the Wixel App file. The second line must be “1.0”. This specifies the version number of the file format used in the file.

The third line and all the lines below it are divided into *sections*. Each *section* has a one-line header at the top of it that specifies the name of the section. The header line consists of 6 equals signs (====) followed by a space, followed by the name of the section. The order of the sections does not matter. The only sections required by the Wixel software are the **cdb** and **hex** sections.

### The hex section

The **hex** section contains an Intel Hex file that specifies the bytes to write to the flash of the Wixel. See the **Intel HEX** ([http://en.wikipedia.org/wiki/Intel\\_HEX](http://en.wikipedia.org/wiki/Intel_HEX)) page on Wikipedia for more information. The flash memory region on the CC2511F32 that is available for Wixel applications consists of addresses 0x400 through 0x77FF (inclusive). Any line of the HEX file that writes to bytes outside of this region will be ignored.

### The license section

The **license** section is a human-readable section that should specify the terms under which others may distribute copies or modifications of the app. The Wixel SDK automatically inserts the MIT license into all Wixel App files because that is required by the Wixel SDK's license.

### The description section

The **description** section is a human-readable section that should describe what the app does or link to a web site about the app.

### The cdb section

The **cdb** section contains the names and addresses of the user-configurable parameters. For each parameter, there must be two lines in this section (not necessarily consecutive) as specified below.

One line contains the address of the parameter, and must be of the form: `L:G$param_NAME$0$0:ADDRESS` where NAME is the name of the parameter and ADDRESS specifies the address of the parameter in the Wixel's flash memory as a 4-digit hexadecimal number (e.g. "11C3").

Another line contains the type of the parameter, and must be of the form: `S:G$param_NAME$0$0(TYPE),D,0,0` where NAME is the name of the parameter and TYPE is the type of the parameter. Currently, the only allowed type is a 32-bit signed integer, which is encoded as "{4}SL:S".

The Wixel SDK generates the cdb of section by running `grep` on the CDB file produced by SDCC during the linking step, selecting all lines containing the string "param". This means you can define a parameter simply by writing the following code in your Wixel App, outside of any function:

```
int32 CODE param_NAME = DEFAULT_VALUE;
```

where NAME is the name of your parameter and DEFAULT\_VALUE is the default value it will have if the user does not change its value. This default value is stored in the **hex** section, not the **cdb** section.

You could put your entire CDB file in the WXL file if you wanted to; the software ignores unrecognized lines. However the CDB file can be hundreds of kilobytes long so this is not encouraged.



Wixel App files usually have non-Windows line endings in the cdb section so they can not be viewed properly in Notepad or other text editors that only recognize Windows line endings.

## 11. The Wixel USB Bootloader

The Wixel comes with a USB bootloader that can be used in conjunction with the Wixel Configuration Utility or WixelCmd to upload apps to the Wixel (no external programmer is required). This section documents some technical details of the bootloader and is intended for advanced users.

### Flash Memory Sections

The bootloader occupies the first 1 KiB (1024 bytes) and the last 2 KiB of the CC2511F32's flash memory. Those sections of memory are protected to prevent accidental corruption of the bootloader. The remaining 29 KiB of flash, known as the application section, is available for the app. The bootloader places no restrictions on what data can be written to the application section. However, the bootloader will consider the application to be invalid and not allow any code in the application section to run if the first byte of the application section (address 0x400) is 0xFF, which should never be the case for an application that is compiled correctly.

The CC2511's standard entry vector and the interrupt vectors are remapped by the bootloader to the beginning of the application section. The application's entry vector should be placed at 0x400. The first interrupt vector should be at 0x403 and consecutive interrupt vectors should be 8 bytes apart.

The application can put the Wixel into bootloader mode by jumping to address 0x6 using an `ljmp` instruction.

The block of flash memory from 0x3CC to 0x3FF in the bootloader is used to store some information that can be read by the application:

- Addresses 0x3CC–0x3DD contain the USB device descriptor of the bootloader, as defined in the USB 2.0 Specification.
- Addresses 0x3E0–0x3E3 contain the serial number of the Wixel as a 32-bit unsigned little-endian integer.
- Addresses 0x3E6–0x3FD contain the serial number of the Wixel in USB string descriptor format.

The bytes in the 0x3CC–0x3FF region not mentioned above are reserved and contain only zeros.

### Startup Procedure

Every time the Wixel powers on, the bootloader’s startup code runs. This code decides whether to launch the bootloader or the application by using the following procedure: First, it configures the three LED lines to have internal pull-down resistors and disables the internal pull-up and pull-down resistors of the other Port 2 pins. Second, if the application is not valid (first byte is 0xFF), it goes into bootloader mode. Third, if the Wixel has USB power and the yellow LED (P2\_2) line is high, it goes into bootloader mode. Finally, if none of these tests have caused it to go into bootloader mode, it runs the application.

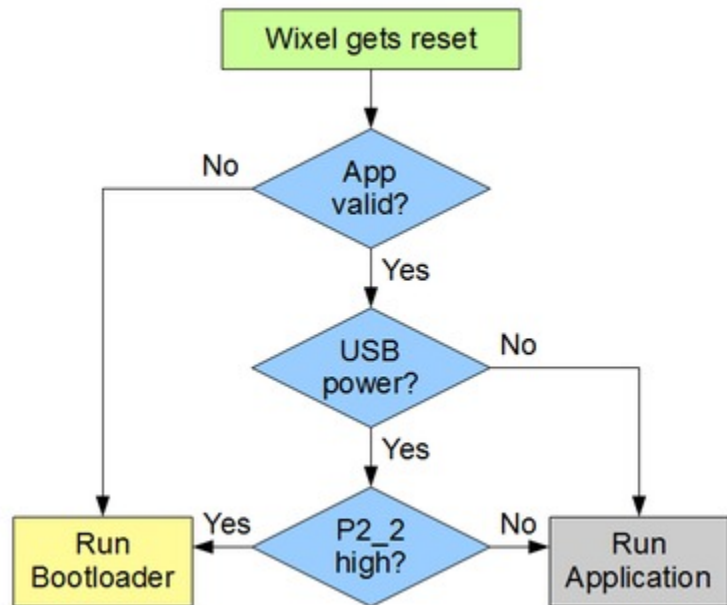

**When the Wixel resets, it uses this procedure to decide whether to run the bootloader or the app.**

#### 11.a. Bootloader Protocol

This section documents the protocol used by Wixel USB Bootloader. This information is for advanced users who want to write their own software for loading apps onto the Wixel. Most users can just use the Wixel Configuration Utility and WixelCmd, which implement this protocol. If you have trouble using this information, please post on the **Wixel section of our forum** [<http://forum.pololu.com/viewforum.php?f=30>].

The Wixel USB Bootloader can be identified by its USB vendor ID and product ID. The bootloader uses the vendor ID of Pololu Corporation, which is 0x1FFB, and its product ID is 0x0100.

The bootloader supports the following USB requests, which are implemented as control transfers on endpoint 0.

#### Request: Read Flash

bmRequestType	0xC0
bRequest	REQUEST_READ_FLASH
wValue	The address of the region of flash to read.
wIndex	0
wLength	The number of bytes to read. Must be greater than 0.

The data transferred from the bootloader will consist of the bytes from the specified region of flash memory.



**Request: Erase Flash Page**

bmRequestType	0xC0
bRequest	REQUEST_ERASE_FLASH
wValue	The address of the page of flash to erase. Must be a multiple of 1024.
wIndex	0
wLength	1

The data transferred from the bootloader will be a one-byte error code. A value of zero indicates success, and the other error codes are listed below.

**Request: Write Flash Block**

bmRequestType	0x40
bRequest	REQUEST_WRITE_FLASH_BLOCK
wValue	The address of the block to write. Must be even.
wIndex	0
wLength	Must be even, greater than 0, and at most 3072.

The data transferred to the bootloader will be written to the specified address in flash and verified. If an error occurs, then the bootloader will respond with a STALL packet in the Status stage and the specific error code can be retrieved using the Get Last Error request.

**Request: Get Last Error**

bmRequestType	0xC0
bRequest	REQUEST_GET_LAST_ERROR
wValue	0
wIndex	0
wLength	1

The data transferred from the bootloader will be a one-byte error code for the last Write Flash Block request. It will be zero if the last Write Flash Block was successful, and the other error codes are listed below.

**Request: Check Application**

bmRequestType	0xC0
bRequest	REQUEST_CHECK_APPLICATION
wValue	0
wIndex	0
wLength	1

The data transferred from the bootloader will be a single byte with a value of 0 if the app is invalid and 1 if the application is valid. The app is considered to be valid if the first byte of the application flash region is not 0xFF.

**Request: Restart**

bmRequestType	0x40
bRequest	REQUEST_RESTART
wValue	The number of milliseconds to delay while disconnected from USB (500 is recommended).
wIndex	0
wLength	0

This request causes the bootloader to disable the USB pull-up resistor on D+, signaling a disconnect from the bus. The bootloader then delays for the specified time, and then does a system reset. The behavior of the Wixel after a reset is documented in **Section 11**. This request is generally used to start running the app.

**Request codes**

Request code	Value
REQUEST_WRITE_FLASH_BLOCK	0x82
REQUEST_GET_LAST_ERROR	0x83
REQUEST_CHECK_APPLICATION	0x84
REQUEST_ERASE_FLASH	0x85
REQUEST_READ_FLASH_BLOCK	0x86
REQUEST_RESTART	0xFE

**Error codes**

Error code	Value	Description
ERROR_LENGTH	2	The wLength parameter was not valid.
ERROR_VERIFICATION	5	Verification of the data written to flash failed.
ERROR_ADDRESS_RANGE	6	The given address was not in the application section.
ERROR_ADDRESS_ALIGNMENT	8	The given address was not properly aligned.

**Tips**

We recommend first erasing the Wixel's flash in ascending order and then writing it in descending order. The last Write Flash Block request should only write the first two bytes of flash and nothing else. Doing this makes it very unlikely that an interrupted firmware upgrade could leave the Wixel in an invalid state. If the firmware upgrade is interrupted, the first byte of flash will almost certainly be 0xFF, so the bootloader will not attempt to run the app.

The requests listed above can only operate on the application section of flash memory (0x400–0x77FF).