



GP-01 Specification

Version V1.0

Copyright ©2021

Disclaimer and copyright notice

The information in this article, including the URL address for reference, is subject to change without notice. The document is provided “as is” and is not liable for any security, including any security for merchantability, application for a particular purpose or non-tort, and any proposal, specification or sample referred to in him. This document shall not be responsible for any kind, including liability for the infringement of any patent rights arising from the use of the information in this document. This document does not hereby grant any intellectual property use license, whether express or implied, in estoppel or otherwise. The test data obtained in this article are from Ai-Thinker laboratory test, actual The results may vary slightly. It is hereby stated that all trademark names, trademarks and registered trademarks mentioned herein are the property of their respective owners.

The final interpretation right belongs to Shenzhen Ai-Thinker Technology Co., Ltd.

Note

Due to product version upgrades or other reasons, the contents of this manual may be changed. Shenzhen Ai-Thinker Technology Co., Ltd. reserves the right to modify the contents of this manual without any notice or prompt. This manual is only used as a guide. Shenzhen Ai-Thinker Technology Co., Ltd. makes every effort to provide accurate information in this manual. However, Shenzhen Ai-Thinker Technology Co., Ltd. does not guarantee that the contents of the manual are completely free of errors. All statements and information in this manual And the suggestion does not constitute any express or implied guarantee.

Document development/revision/revocation resume

Version	Date	Revised content	Make	Verify
V1.0	2021.7.15	First Edition	Qijing Zhang	Ning Guan

Content

1. Product overview	5
1.1. Major parameters	6
2. Electrical parameters	6
2.1. Performance	6
2.2. Analog characteristics	7
3. Dimensions	9
4. Pin definition	9
5. Schematic diagram	12
6. Design guidance	13
6.1. Application circuit	13
6.2. Antenna layout requirements	13
6.3. Power supply	13
6.4. Use of GPIO port	14
7. Reflow soldering curve	15
8. Packaging	16
9. Related models	16
10. Contact us	17

1. Product overview

GP-01 is a high-performance BDS/GNSS multi-mode satellite navigation receiver SOC module, which integrates RF front-end, digital baseband processor, 32-bit RISC CPU, power management and active antenna detection and protection functions. Support a variety of satellite navigation systems, including China's Beidou satellite navigation system BDS, the United States' GPS, and Russia's GLONASS, which can realize multi-system joint positioning.

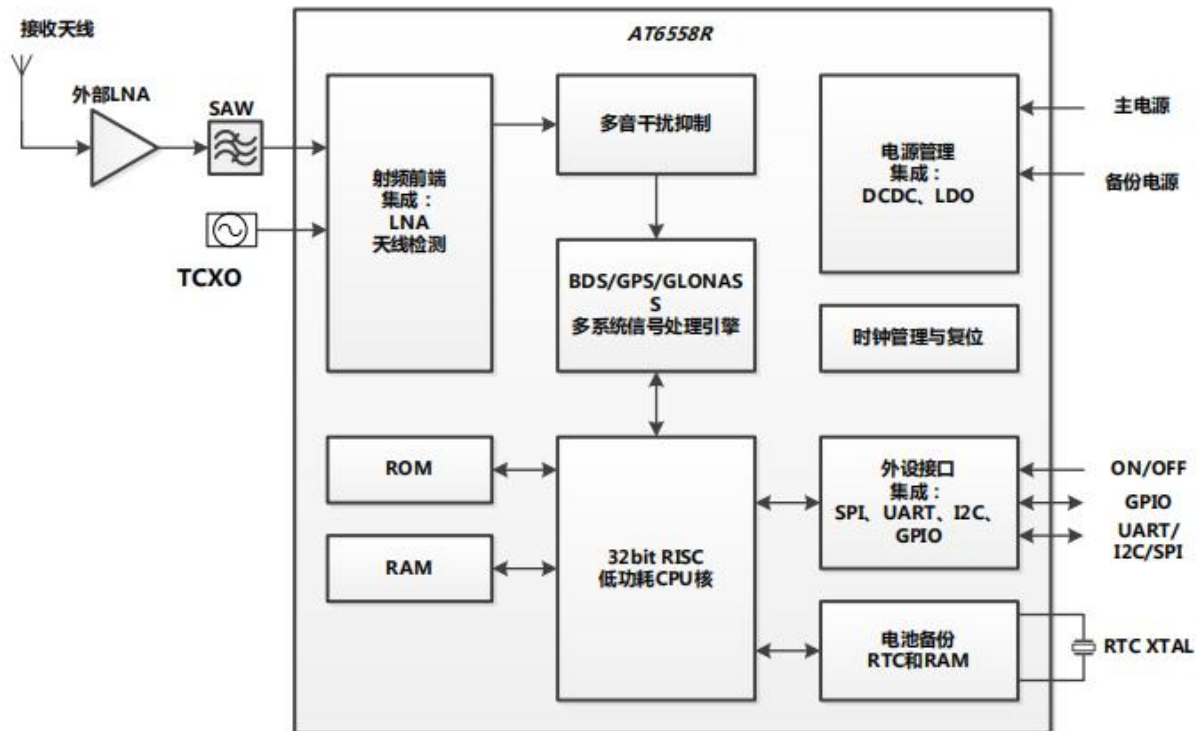

Figure 1 Chip architecture diagram

1.1. Major parameters

List 1 Major parameters description

Model	GP-01
Size	16.2*12.2*2.4(±0.2)MM
Operating temperature	-40 °C ~ 85 °C
Storage environment	-40 °C ~ 125 °C , < 90%RH
Power supply range	Supply voltage 2.7V ~ 3.6V, typical 3.3V
Serial port rate	Maximum support 256000bps
Certification	RoHS

2. Electrical parameters

2.1. Performance

List 2 Electrical parameters description

Technical parameters	Test items	Value	Unit
TTF	Cold start	≤32	s
	Hot Start	≤1	s
	Recapture	≤1	s

Sensitivity	Cold start	-148	dBm
	Hot start	-156	dBm
	Recapture	-160	dBm
	Tracking mode	-162	dBm
Accuracy	Positioning accuracy	<2	m (1 σ)
	Timing accuracy	<30	ns (1 σ)
	Speed measurement accuracy	<0.1	m/s (1 σ)
	Positioning update rate	1	Hz(Max 5Hz)
Power consumption	BDS/GPS dual-mode continuous operation	23	mA
	Sleep mode	5	mA
	Standby	8	μ A

2.2. Analog characteristics

List 3 Description of analog characteristics

No.	Parameters	Condition	Parameters			Unit
			Min	Typical	Max	
1	Reset voltage	@VDD_IO	2.35	2.45	2.6	V
2	Reset time	Crystal frequency 26MHz		160		ms
3	TCXO Crystal frequency			26		MHz

4	TCXO amplitude		0.5	1.5		Vpp
5	Active antenna detection current		2.5			mA
6	Active antenna short circuit protection current		45	50	60	mA
7	Antenna detection circuit voltage drop	input3.3V, 50mA load			0.3	V
8	Working current	@3.3V BDS+GPS		23		mA
9	Battery backup current			8		uA
10	Sleep mode current	ON_OFF=0		5		mA
11	RTC Crystal frequency			32.768		KHz
12	RTC Crystal Equivalent series resistance				80	KΩ
13	RTC Crystal Series capacitance			8		pF

3. Dimensions

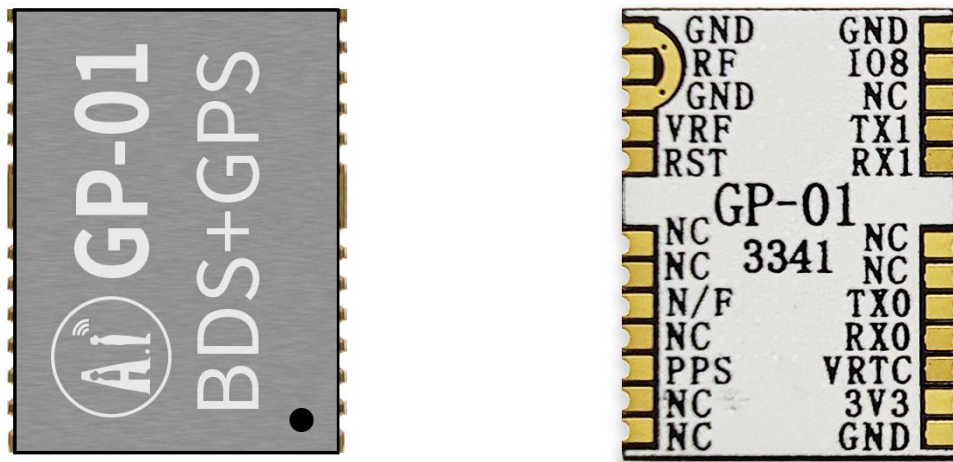

Figure 2 Appearance map (pictures and silk screens are for reference only, the actual product shall prevail)

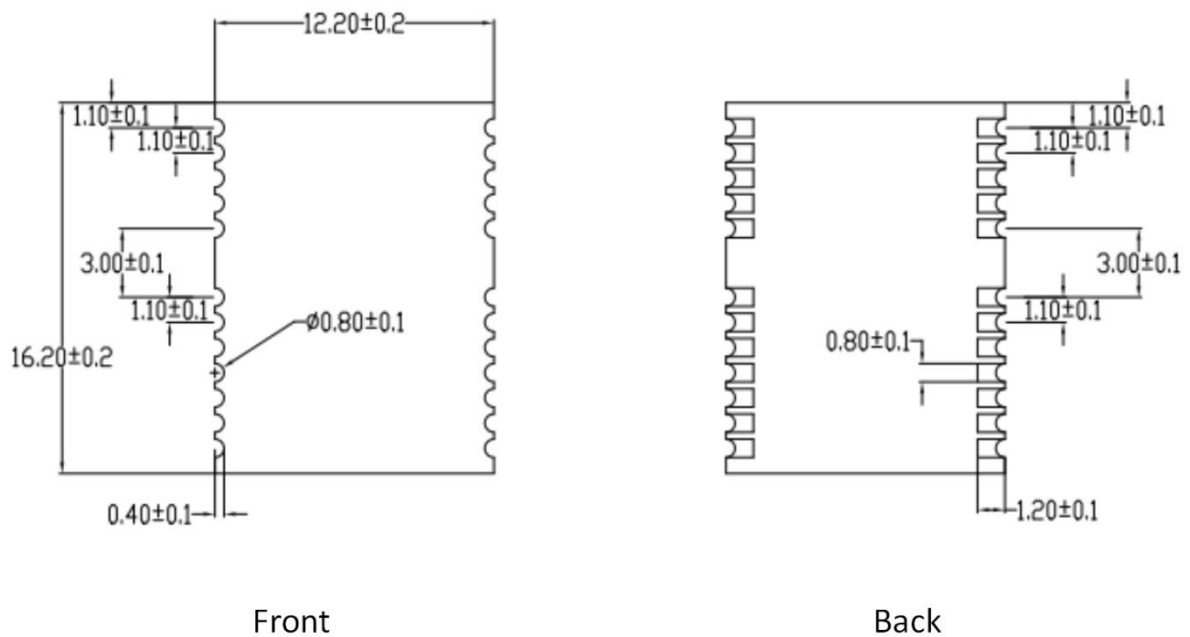

Figure 3 dimensions

4. Pin definition

The GP-01 module has a total of 24 interfaces. As shown in the pin diagram, the pin

function definition table is the interface definition.

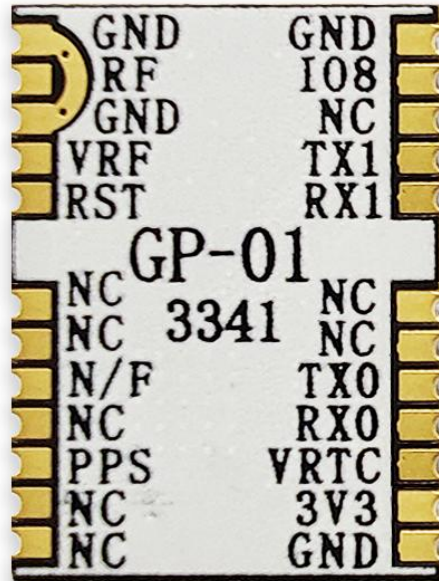

Figure 4 Pin diagram

List 4 Pin function definition

No.	Name	Function description
1	NC	No connect
2	NC	No connect
3	PPS	Time pulse signal
4	NC	No connect
5	N/F	Shutdown control, keep high level during normal operation; internal pull-up
6	NC	No connect
7	NC	No connect
8	RST	External reset input, internal pull-up, it must be left floating if not used
9	VRF	Power supply and detection of active antenna

10	GND	Grounded
11	RF	RF input
12	GND	Grounded
13	GND	Grounded
14	IO8	General-purpose GPIO, the default is the mode configuration. When high level or floating, it is BDS+GPS; when low level, it is GPS+GLONASS.
15	NC	No connect
16	TX1	General purpose GPIO, the default is TXD of UART1
17	RX1	General purpose GPIO, the default is RXD of UART1
18	NC	No connect
19	NC	No connect
20	TX0	General-purpose GPIO, the default is TXD of UART0
21	RX0	General GPIO, the default is RXD of UART0
22	VRTC	Backup power for internal RTC, 1.4~3.6V
23	3V3	3.3V power supply
24	GND	Grounded

5. Schematic diagram

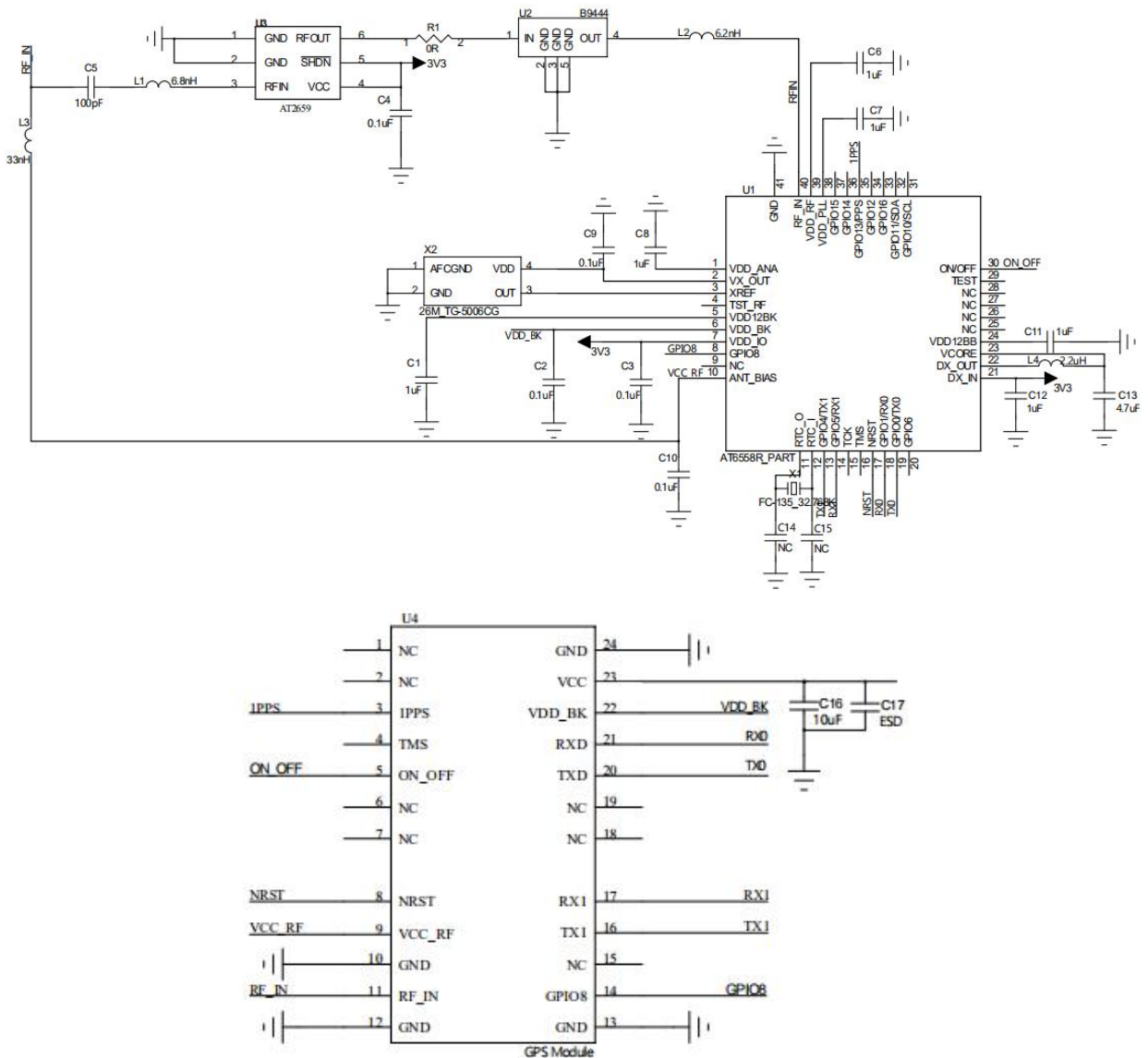

Figure 5 Module schematic

6. Design guidance

6.1. Application circuit

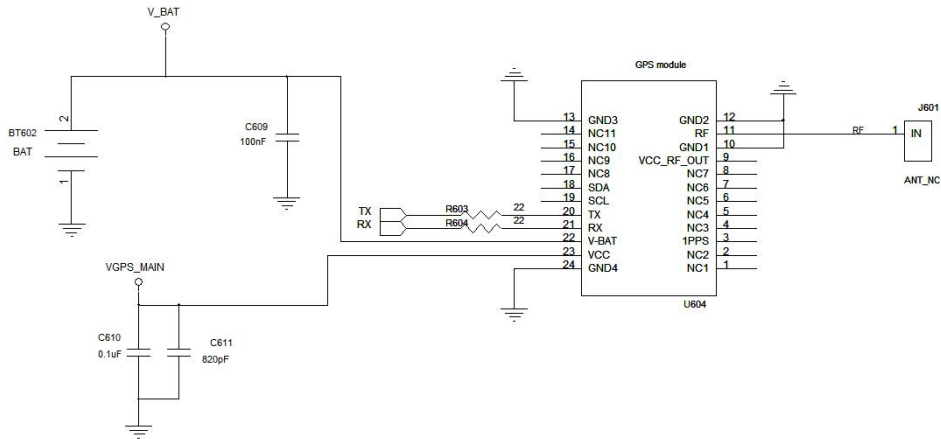

Figure 6 Application circuit schematic

6.2. Antenna layout requirements

- GP-01 needs to be used with soldering antenna, and there is an antenna pad on the module.
- In order to achieve the best effect of the antenna, the location of the antenna assembly should be far away from metal parts and high-frequency components.

6.3. Power supply

- Recommend 3.3V voltage, peak current above 30mA.
- It is recommended to use LDO for power supply; if DC-DC is used, the ripple is recommended to be controlled within 50mV.
- It is recommended to reserve the position of the dynamic response capacitor for the DC-DC power supply circuit to optimize the output ripple when the load changes greatly.
- It is recommended to add ESD devices to the 3.3V power interface.

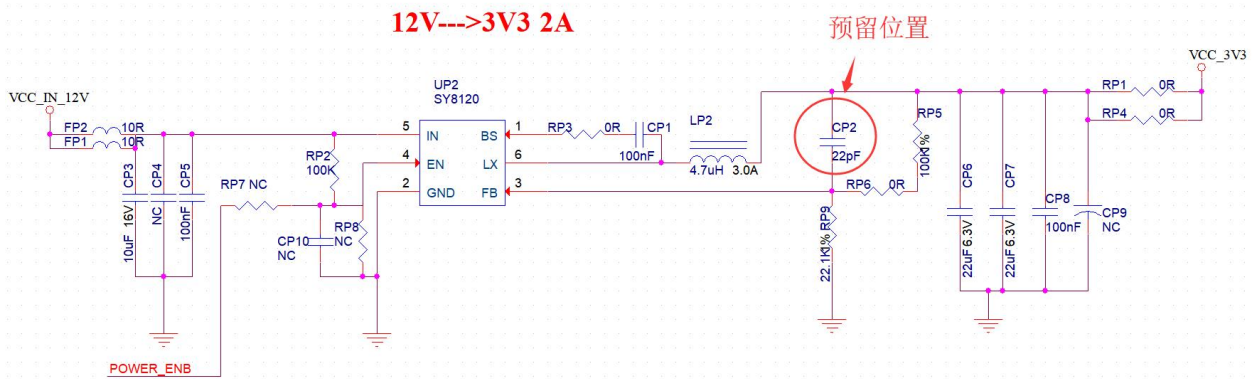

Figure 7 DC-DC Reference design drawing

6.4. Use of GPIO port

- There are some GPIO ports on the periphery of the module. If you need to use it, it is recommended to connect a 10-100 ohm resistor in series with the IO port. This can suppress overshoot and make the levels on both sides more stable. It is helpful for EMI and ESD.
- For the pull-up and pull-down of special IO ports, please refer to the instructions in the specification, which will affect the startup configuration of the module.
- The IO port of the module is 3.3V. If the main control and the IO level of the module do not match, a level conversion circuit needs to be added.
- If the IO port is directly connected to a peripheral interface or terminal such as a header, it is recommended to reserve an ESD device near the terminal on the IO trace.

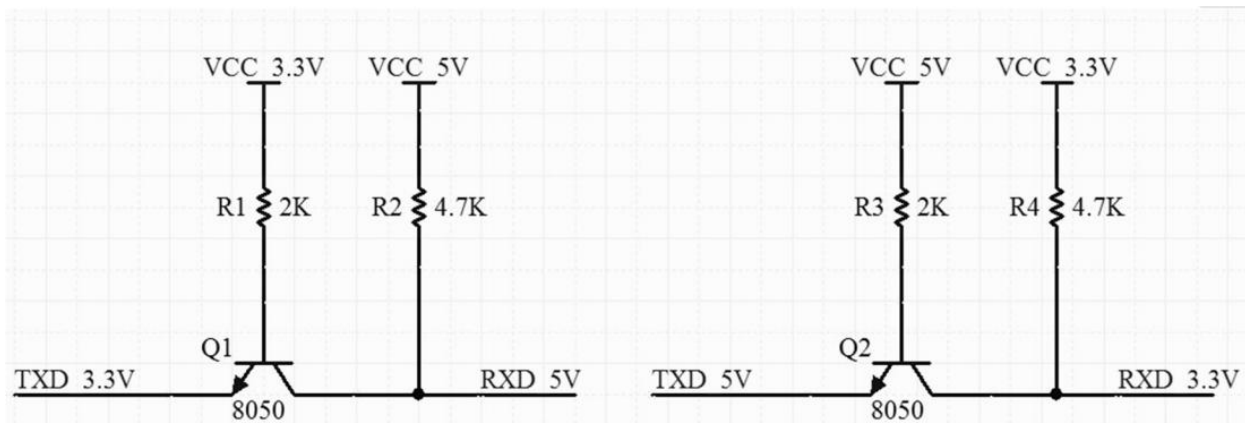

Figure 8 Level conversion circuit

7. Reflow soldering curve

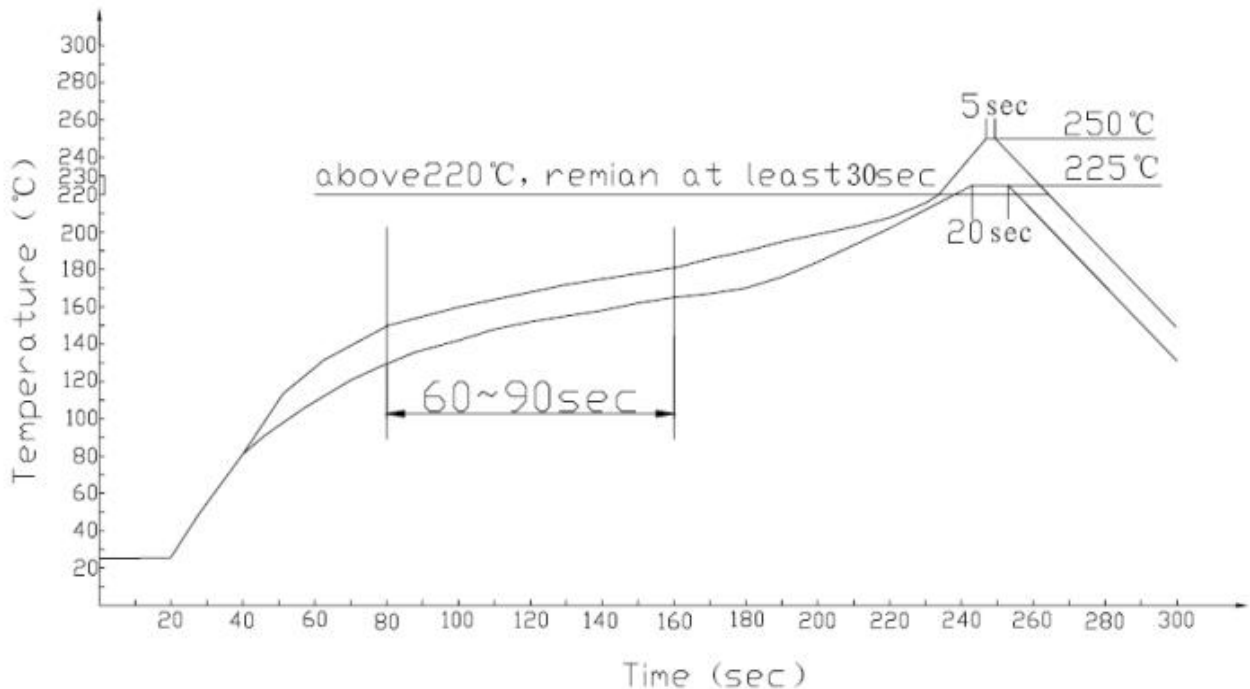

Figure 9 reflow soldering curve

! Attention

Adjust the balance time to ensure the rationalization of the gas when the solder paste melts. If there are too many gaps on the PCB, the equilibration time can be increased. Considering that the product is placed in the welding area for a long time (the temperature is above 180°C), in order to prevent damage to the components and the bottom plate, the placement time should be shortened as much as possible.

! Important characteristics of the curve:

Ascent speed=1~4°C /sec, 25°C to 150°C

Average preheat temperature=140°C to 150°C, 60sec~90sec

Temperature fluctuation=225°C to 250°C, about 30sec

Decent speed=2~6°C/sec, to 183°C, about 15sec

Total time=about 300sec

8. Packaging

As shown in the figure below, the packaging of GP-01 is braid.



Figure10 Packaging taping diagram

9. Related models

List 5 Related model table

Model	Power supply	Package	Size	Interface
GP-01 module	3.3V	SMD-24	16.2*12.2*2.4(±0.2)MM	UART
GP-02 module	3.3V	SMD-18	10.3*9.9*2.4(±0.2)MM	UART
GP-01-Kit development board	5V	SMD-8	26*24.1(±0.2)MM	UART
GP-02-Kit development board	5V	SMD-6	18*20.3(±0.2)MM	UART
Product related information: https://docs.ai-thinker.com/gps				

10. Contact us

Website: <https://www.ai-thinker.com>

Development DOCS: <https://docs.ai-thinker.com>

Forum: <http://bbs.ai-thinker.com>

Sample purchase: <https://aithinker.tmall.com>

<https://anxinke.taobao.com>

Business: overseas@aithinker.com

Technical support: support@aithinker.com

Address: Room410, Building C, Huafeng Intelligence Innovation Port,

Gushu, Xixiang, Baoan District, Shenzhen China 518126

Tel: 0755-29162996

