

# **Application Manual**

## **RV-3028-C7**

### **Extreme Low Power Real-Time Clock Module with I<sup>2</sup>C-Bus Interface**

## TABLE OF CONTENTS

<b>1. OVERVIEW .....</b>	<b>6</b>
<b>1.1. GENERAL DESCRIPTION.....</b>	<b>6</b>
<b>1.2. APPLICATIONS.....</b>	<b>7</b>
<b>1.3. ORDERING INFORMATION.....</b>	<b>7</b>
<b>2. BLOCK DIAGRAM.....</b>	<b>8</b>
<b>2.1. PINOUT.....</b>	<b>9</b>
<b>2.2. PIN DESCRIPTION.....</b>	<b>9</b>
<b>2.3. FUNCTIONAL DESCRIPTION.....</b>	<b>10</b>
<b>2.4. DEVICE PROTECTION DIAGRAM.....</b>	<b>10</b>
<b>3. REGISTER ORGANIZATION.....</b>	<b>11</b>
<b>3.1. REGISTER CONVENTIONS.....</b>	<b>11</b>
<b>3.2. REGISTER OVERVIEW.....</b>	<b>12</b>
<b>3.3. CLOCK REGISTERS.....</b>	<b>14</b>
<b>3.4. CALENDAR REGISTERS.....</b>	<b>16</b>
<b>3.5. ALARM REGISTERS.....</b>	<b>18</b>
<b>3.6. PERIODIC COUNTDOWN TIMER CONTROL REGISTERS.....</b>	<b>20</b>
<b>3.7. STATUS AND CONTROL REGISTERS.....</b>	<b>22</b>
<b>3.8. EVENT CONTROL REGISTER.....</b>	<b>26</b>
<b>3.9. TIME STAMP REGISTERS.....</b>	<b>27</b>
<b>3.10. UNIX TIME REGISTERS.....</b>	<b>30</b>
<b>3.11. RAM REGISTERS.....</b>	<b>31</b>
<b>3.12. PASSWORD REGISTERS.....</b>	<b>32</b>
<b>3.13. EEPROM MEMORY CONTROL REGISTERS.....</b>	<b>33</b>
<b>3.14. ID REGISTER.....</b>	<b>35</b>
<b>3.15. CONFIGURATION EEPROM WITH RAM MIRROR REGISTERS.....</b>	<b>35</b>
3.15.1. EEPROM RESERVED.....	35
3.15.2. EEPROM PASSWORD ENABLE REGISTER.....	35
3.15.3. EEPROM PASSWORD REGISTERS.....	36
3.15.4. EEPROM CLKOUT REGISTER.....	37
3.15.5. EEPROM OFFSET REGISTER.....	38
3.15.6. EEPROM BACKUP REGISTER.....	39
<b>3.16. USER EEPROM.....</b>	<b>40</b>
<b>3.17. RESERVED EEPROM.....</b>	<b>40</b>
<b>3.18. REGISTER RESET VALUES SUMMARY.....</b>	<b>41</b>
<b>4. DETAILED FUNCTIONAL DESCRIPTION.....</b>	<b>44</b>
<b>4.1. POWER ON RESET (POR).....</b>	<b>44</b>
<b>4.2. AUTOMATIC BACKUP SWITCHOVER FUNCTION.....</b>	<b>45</b>
4.2.1. SWITCHOVER DISABLED.....	46

4.2.2. DIRECT SWITCHING MODE (DSM) .....	46
4.2.3. LEVEL SWITCHING MODE (LSM) .....	47
<b>4.3. TRICKLE CHARGER .....</b>	<b>48</b>
<b>4.4. PROGRAMMABLE CLOCK OUTPUT .....</b>	<b>48</b>
4.4.1. CLKOUT FREQUENCY SELECTION .....	49
4.4.2. NORMAL CLOCK OUTPUT .....	49
4.4.3. INTERRUPT CONTROLLED CLOCK OUTPUT .....	49
4.4.4. SYNCHRONIZED ENABLE/DISABLE .....	50
4.4.5. CLOCK OUTPUT SCHEME .....	51
<b>4.5. SETTING AND READING THE TIME .....</b>	<b>52</b>
4.5.1. SETTING THE TIME .....	53
4.5.2. READING THE TIME .....	53
<b>4.6. EEPROM READ/WRITE .....</b>	<b>54</b>
4.6.1. POR REFRESH (ALL CONFIGURATION EEPROM → RAM) .....	54
4.6.2. AUTOMATIC REFRESH (ALL CONFIGURATION EEPROM → RAM) .....	54
4.6.3. UPDATE (ALL CONFIGURATION RAM → EEPROM) .....	54
4.6.4. REFRESH (ALL CONFIGURATION EEPROM → RAM) .....	54
4.6.5. WRITE TO ONE EEPROM BYTE (EEDATA (RAM) → EEPROM) .....	55
4.6.6. READ ONE EEPROM BYTE (EEPROM → EEDATA (RAM)) .....	55
4.6.7. EEBUSY BIT .....	56
4.6.8. EEPROM READ/WRITE CONDITIONS .....	57
4.6.9. USE OF THE CONFIGURATION REGISTERS .....	57
<b>4.7. INTERRUPT OUTPUT .....</b>	<b>58</b>
4.7.1. SERVICING INTERRUPTS .....	58
4.7.2. INTERRUPT SCHEME .....	59
<b>4.8. PERIODIC COUNTDOWN TIMER INTERRUPT FUNCTION .....</b>	<b>61</b>
4.8.1. PERIODIC COUNTDOWN TIMER DIAGRAM .....	62
4.8.2. USE OF THE PERIODIC COUNTDOWN TIMER INTERRUPT .....	63
4.8.3. FIRST PERIOD DURATION .....	65
4.8.4. SINGLE MODE (TRPT = 0) .....	65
4.8.5. REPEAT MODE (TRPT = 1) .....	65
<b>4.9. PERIODIC TIME UPDATE INTERRUPT FUNCTION .....</b>	<b>66</b>
4.9.1. PERIODIC TIME UPDATE DIAGRAM .....	66
4.9.2. USE OF THE PERIODIC TIME UPDATE INTERRUPT .....	67
<b>4.10. ALARM INTERRUPT FUNCTION .....</b>	<b>68</b>
4.10.1. ALARM DIAGRAM .....	68
4.10.2. USE OF THE ALARM INTERRUPT .....	69
<b>4.11. EXTERNAL EVENT INTERRUPT FUNCTION .....</b>	<b>70</b>
4.11.1. EXTERNAL EVENT DIAGRAM .....	71

4.11.2. USE OF THE EXTERNAL EVENT INTERRUPT .....	72
4.11.3. EDGE DETECTION (ET = 00) .....	73
4.11.4. LEVEL DETECTION WITH FILTERING (ET ≠ 00) .....	73
<b>4.12. AUTOMATIC BACKUP SWITCHOVER INTERRUPT FUNCTION.....</b>	<b>74</b>
4.12.1. AUTOMATIC BACKUP SWITCHOVER DIAGRAM .....	75
4.12.2. USE OF THE AUTOMATIC BACKUP SWITCHOVER INTERRUPT .....	76
<b>4.13. POWER ON RESET INTERRUPT FUNCTION .....</b>	<b>77</b>
4.13.1. POWER ON RESET DIAGRAM .....	77
4.13.2. USE OF THE POWER ON RESET INTERRUPT .....	78
<b>4.14. TIME STAMP FUNCTION .....</b>	<b>79</b>
<b>4.15. FREQUENCY OFFSET CORRECTION.....</b>	<b>81</b>
4.15.1. EEOFFSET VALUE DETERMINATION.....	81
4.15.2. VERIFICATION OF THE CORRECTED TIME ACCURACY .....	81
<b>4.16. UNIX TIME COUNTER.....</b>	<b>82</b>
4.16.1. SETTING THE UNIX TIME .....	82
4.16.2. READING THE UNIX TIME .....	84
<b>4.17. RESET BIT FUNCTION .....</b>	<b>85</b>
<b>4.18. USER PROGRAMMABLE PASSWORD.....</b>	<b>87</b>
4.18.1. ENABLE/DISABLE WRITE PROTECTION.....	87
4.18.2. CHANGING PASSWORD.....	88
4.18.3. FLOWCHART.....	89
<b>5. I<sup>2</sup>C INTERFACE .....</b>	<b>90</b>
<b>5.1. BIT TRANSFER .....</b>	<b>90</b>
<b>5.2. START AND STOP CONDITIONS .....</b>	<b>90</b>
<b>5.3. DATA VALID.....</b>	<b>91</b>
<b>5.4. SYSTEM CONFIGURATION.....</b>	<b>91</b>
<b>5.5. ACKNOWLEDGE.....</b>	<b>92</b>
<b>5.6. SLAVE ADDRESS .....</b>	<b>93</b>
<b>5.7. WRITE OPERATION.....</b>	<b>93</b>
<b>5.8. READ OPERATION AT SPECIFIC ADDRESS.....</b>	<b>94</b>
<b>5.9. READ OPERATION .....</b>	<b>94</b>
<b>5.10. I<sup>2</sup>C-BUS IN SWITCHOVER CONDITION.....</b>	<b>95</b>
<b>6. ELECTRICAL SPECIFICATIONS.....</b>	<b>96</b>
<b>6.1. ABSOLUTE MAXIMUM RATINGS .....</b>	<b>96</b>
<b>6.2. OPERATING PARAMETERS .....</b>	<b>97</b>
6.2.1. TYPICAL CHARACTERISTICS .....	99
<b>6.3. OSCILLATOR PARAMETERS .....</b>	<b>100</b>
6.3.1. XTAL FREQUENCY VS. TEMPERATURE CHARACTERISTICS .....	100
<b>6.4. POWER ON AC ELECTRICAL CHARACTERISTICS .....</b>	<b>101</b>

---

6.5. <i>I<sup>2</sup>C</i> -BUS CHARACTERISTICS.....	102
7. TYPICAL APPLICATION CIRCUIT .....	103
7.1. OPERATING RV-3028-C7 WITH BACKUP SUPPLY VOLTAGE.....	103
8. PACKAGE.....	104
8.1. DIMENSIONS AND SOLDER PAD LAYOUT.....	104
8.1.1. RECOMMENDED THERMAL RELIEF .....	104
8.2. MARKING AND PIN #1 INDEX.....	105
9. MATERIAL COMPOSITION DECLARATION & ENVIRONMENTAL INFORMATION .....	106
9.1. HOMOGENOUS MATERIAL COMPOSITION DECLARATION .....	106
9.2. MATERIAL ANALYSIS & TEST RESULTS .....	107
9.3. RECYCLING MATERIAL INFORMATION .....	108
9.4. ENVIRONMENTAL PROPERTIES & ABSOLUTE MAXIMUM RATINGS .....	109
10. SOLDERING INFORMATION.....	110
11. HANDLING PRECAUTIONS FOR MODULES WITH EMBEDDED CRYSTALS .....	111
12. PACKING & SHIPPING INFORMATION.....	112
13. COMPLIANCE INFORMATION .....	113
14. DOCUMENT REVISION HISTORY.....	113

## RV-3028-C7

### Extreme Low Power Real-Time Clock (RTC) Module with I<sup>2</sup>C-Bus Interface

#### 1. OVERVIEW

- RTC module with built-in 32.768 kHz “Tuning Fork” crystal oscillator
- Counters for seconds, minutes, hours, date, month, year and weekday
- 32-bit UNIX Time counter
- Automatic leap year correction: 2000 to 2099
- Aging compensation with user programmable EEPROM Offset value (Factory Calibrated value may be changed by the user)
- Periodic Countdown Timer Interrupt function; interrupt output also in VBACKUP Power state
- Periodic Time Update Interrupt function (seconds, minutes); interrupt output also in VBACKUP Power state
- Alarm Interrupts for weekday or date, hour and minute settings; interrupt output also in VBACKUP Power state
- External Event Input with Interrupt and Time Stamp function; interrupt output also in VBACKUP Power state
- Factory calibrated time accuracy:  $\pm 1$  ppm @ 25°C (EEPROM Offset value may be changed by the user)
- 32.768 kHz Xtal frequency accuracy:  $\pm 5$  ppm @ 25°C
- 43 bytes of user EEPROM
- Configuration registers stored in EEPROM and mirrored in RAM
- User programmable password for write protection of the time, control and configuration registers
- I<sup>2</sup>C-bus interface (up to 400 kHz)
- Programmable Clock Output
  - Enable/disable by CLKOE bit
  - Enable by an Interrupt function
  - 32.768 kHz, 8192 Hz, 1024 Hz, 64 Hz, 32 Hz, 1 Hz
  - Periodic countdown timer interrupt as clock output frequency
  - Synchronized enable/disable
- Automatic Backup switchover with Interrupt and Time Stamp function
- Internal Power On Reset (POR) with Interrupt function
- Trickle charger
- Wide interface operating voltage: 1.2 to 5.5 V
- Wide Timekeeping voltage range: 1.1 to 5.5 V
- Extreme low current consumption: 40 nA ( $V_{DD} = 3.0$  V,  $T_A = 25^\circ\text{C}$ )
- Operating temperature range: -40 to +85°C
- Ultra small and compact C7 package size (3.2 x 1.5 x 0.8 mm), RoHS-compliant and 100% lead-free
- Automotive qualification according to AEC-Q200 available

#### 1.1. GENERAL DESCRIPTION

The RV-3028-C7 is a CMOS real-time clock/calendar module with an automatic backup switchover circuit and is optimized for extreme low power consumption. It provides full RTC function with programmable counters, alarm, selectable interrupt and clock output functions and also a 32-bit UNIX Time counter. The internal EEPROM memory hosts all configuration settings and allows for additional user memory. An EEOffset value allows compensating the frequency deviation of the 32.768 kHz clock. Addresses and data are transmitted via an I<sup>2</sup>C-bus interface for communication with a host controller. The Address Pointer is incremented automatically after each written or read data byte.

This ultra small RTC module has been specially designed for miniature and cost sensitive high volume applications.

## 1.2. APPLICATIONS

The RV-3028-C7 RTC module combines key functions with outstanding performance in an ultra small ceramic package:

- Extreme Low Power consumption
- Smallest RTC module (embedded XTAL) in an ultra-small 3.2 x 1.5 x 0.8 mm lead-free ceramic package

These unique features make this product perfectly suitable for many applications:

- Communication: IoT / Wearables / Wireless Sensors and Tags / Handsets
- Automotive: M2M / Navigation & Tracking Systems / Dashboard / Tachometers / Engine Controller  
Car Audio & Entertainment Systems
- Metering: E-Meter / Heating Counter / Smart Meters / PV Converter/ Utility metering
- Outdoor: ATM & POS systems / Surveillance & Safety systems / Ticketing Systems
- Medical: Glucose Meter / Health Monitoring Systems
- Safety: Security & Camera Systems / Door Lock & Access Control / Tamper Detection
- Consumer: Gambling Machines / TV & Set Top Boxes / White Goods
- Automation: PLC / Data Logger / Home & Factory Automation / Industrial and Consumer Electronics

## 1.3. ORDERING INFORMATION

Example: RV-3028-C7 TA QC

Code	Operating temperature range
TA (Standard)	-40 to +85°C

Code	Qualification
QC (Standard)	Commercial Grade
QA	Automotive Grade AEC-Q200

## 2. BLOCK DIAGRAM

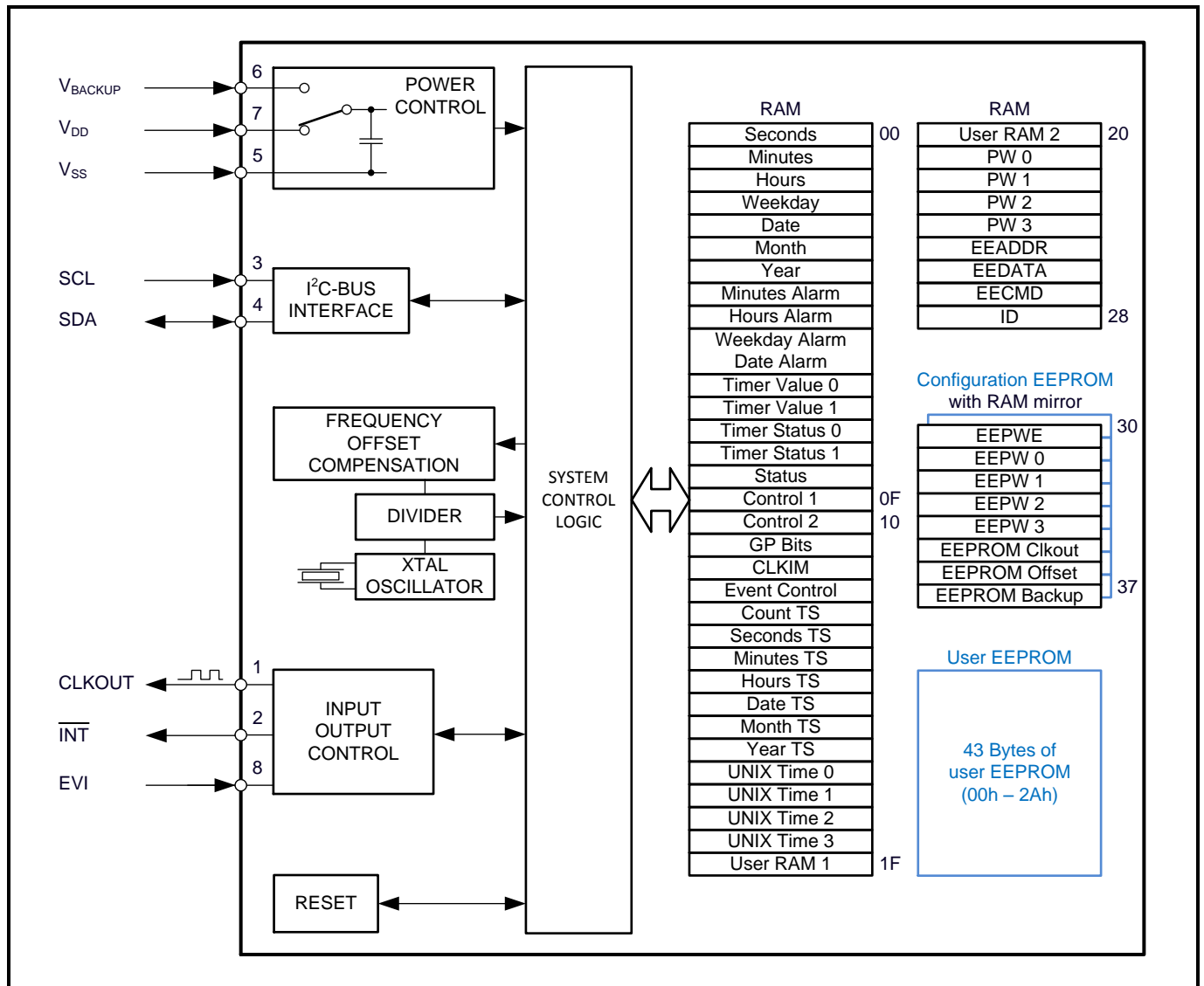



## 2.1. PINOUT

RV-3028-C7 Package: (top view)

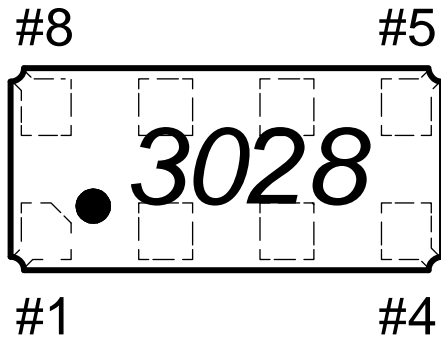

#1	CLKOUT
#2	$\overline{\text{INT}}$
#3	SCL
#4	SDA
#5	$V_{\text{SS}}$
#6	$V_{\text{BACKUP}}$
#7	$V_{\text{DD}}$
#8	EVI

## 2.2. PIN DESCRIPTION

Symbol	Pin #	Description
CLKOUT	1	<p>Clock Output; push-pull; Normal and Interrupt driven clock output can be activated concurrently.</p> <ol style="list-style-type: none"> <li>1. Normal clock output is controlled by the CLKOE bit (EEPROM 35h). When CLKOE is set to 1 (default), the CLKOUT pin drives the square wave on the CLKOUT pin. When CLKOE bit is set to 0, the CLKOUT pin is LOW.</li> <li>2. Interrupt driven clock output is controlled by an interrupt event. When CLKIE bit (10h) is set to 1 the occurrence of the interrupt selected in the Clock Interrupt Mask Register (12h) allows the square wave output on the CLKOUT pin. Writing 0 to CLKIE will disable new interrupts from driving square wave on CLKOUT. When CLKF flag is cleared, the CLKOUT pin is LOW.</li> </ol> <p>Depending of the settings in the FD field (EEPROM 35h), the CLKOUT pin can drive the square wave of 32.768 kHz (default), 8192 Hz, 1024 Hz, 64 Hz, 32 Hz or 1 Hz, or the predefined periodic countdown timer interrupt. When FD field is 111 the CLKOUT pin is LOW.</p> <p>When CLKSYS bit (EEPROM 35h) set to 1, the enabling and disabling of the clock output is synchronized. CLKSYS has no effect on the timer interrupt signal.</p> <p>In VBACKUP Power state, the CLKOUT pin is LOW.</p>
$\overline{\text{INT}}$	2	Interrupt Output; open-drain; active LOW; requires pull-up resistor; used to output Periodic Countdown Timer, Periodic Time Update, Alarm, External Event, Automatic Backup Switchover and Power On Reset Interrupt signals. Interrupt output also in VBACKUP Power state.
SCL	3	I <sup>2</sup> C Serial Clock Input; requires pull-up resistor. In VBACKUP Power state, the SCL pin is disabled.
SDA	4	I <sup>2</sup> C Serial Data Input-Output; open-drain; requires pull-up resistor. In VBACKUP Power state, the SDA pin is disabled (high impedance).
$V_{\text{SS}}$	5	Ground.
$V_{\text{BACKUP}}$	6	Backup Supply Voltage. When the backup switchover function is not needed, $V_{\text{BACKUP}}$ must be tied to $V_{\text{SS}}$ with a 10 k $\Omega$ resistor.
$V_{\text{DD}}$	7	Power Supply Voltage.
EVI	8	External Event Input; used for interrupt generation, interrupt driven clock output and time stamp function. Remains active also in VBACKUP Power state. This pin should not be left floating.

### 2.3. FUNCTIONAL DESCRIPTION

The RV-3028-C7 is an extreme-low power CMOS based Real-Time-Clock Module with embedded 32.768 kHz crystal oscillator. It includes an Automatic Backup switchover function with a Trickle charger where the interrupt output pin  $\overline{\text{INT}}$  is also working in VBACKUP Power state. The clock output on CLKOUT pin can be enabled normally via command over I<sup>2</sup>C interface or can be interrupt driven and synchronized clock output enable/disable on CLKOUT pin can be freely selected. The configuration registers are stored permanently in EEPROM and mirrored in RAM in order that the RTC module is still configured correctly even after power down. For safety against inadvertent overwriting the time, control and configuration registers can be protected by a User Programmable Password. Additionally, there is an EEPROM Offset value customer use for aging correction.

The RV-3028-C7 provides standard Clock & Calendar function including seconds, minutes, hours (12 or 24 h), weekdays, date, months, years (with leap year correction) and interrupt functions for the Periodic Countdown Timer, Periodic Time Update, Alarm, External Event, Automatic Backup Switchover and Power On Reset. All is accessible via I<sup>2</sup>C-bus (2-wire Interface). The interrupt functions and the Time Stamp of the External Event function are also working in VBACKUP Power state. Beside the standard RTC functions a 32-bit UNIX Time counter and 43 Bytes of User Memory EEPROM and 2 Bytes of User RAM are provided. A further Byte can be used as User RAM when the Periodic Countdown Timer is not used (Timer Value register 0Ah) and a further Byte when the Alarm function is not used (Alarm register 07h).

The registers are accessed by selecting a register address and then performing read or write operations. Multiple reads or writes can be performed in a single access, with the address automatically incremented after each byte by the Address Pointer. When address is automatically incremented, wrap around occurs from address 3Fh to address 00h (see figure below). All registers are designed as addressable 8-bit registers despite the fact that not all registers and bits are implemented.

Handling address registers:

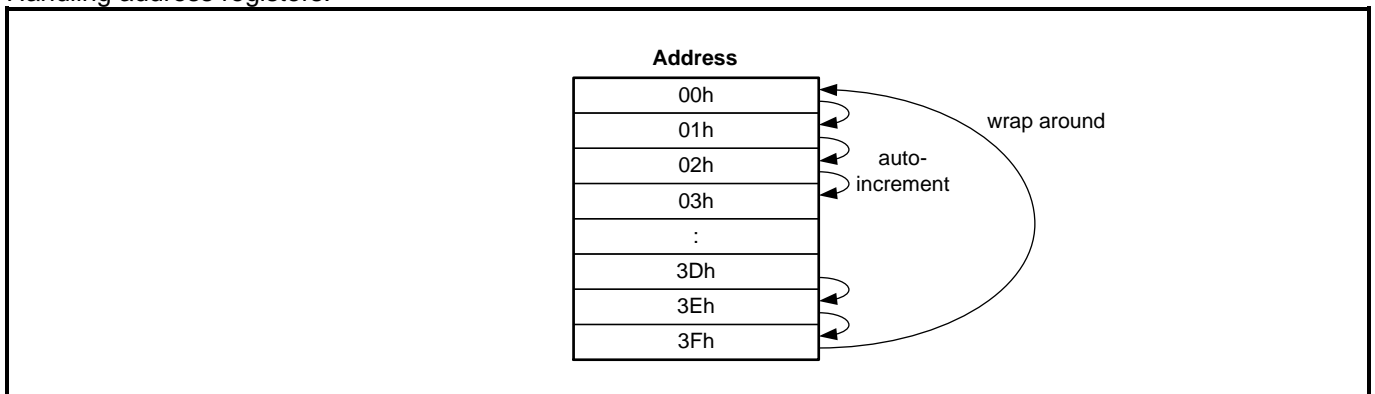

### 2.4. DEVICE PROTECTION DIAGRAM

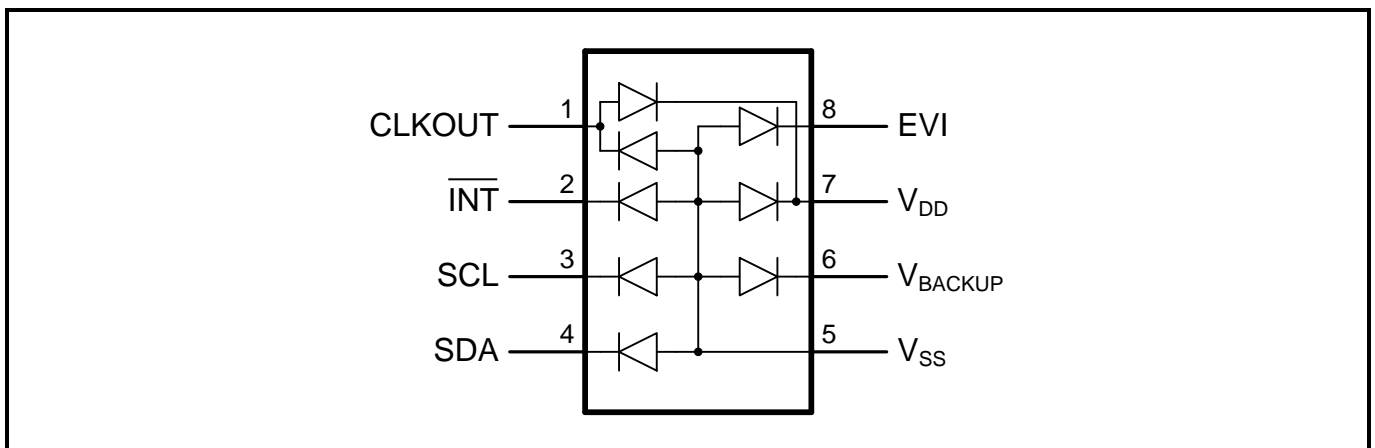

### 3. REGISTER ORGANIZATION

- RAM Registers at addresses 00h to 28h are accessed by selecting a register address and then performing read or write operations. Multiple reads or writes may be executed in a single access, with the address automatically incrementing after each byte.
- The Configuration Registers at addresses 30h to 37h are memorized in EEPROM and mirrored in RAM. For the RAM mirror, multiple reads or writes may be executed in a single access, with the address automatically incrementing after each byte.
- There are 43 bytes of non-volatile user memory EEPROM at addresses 00h to 2Ah for general use.

The following tables summarize the function of each register.

#### 3.1. REGISTER CONVENTIONS

The conventions in this table serve as a key for the register overview and individual register diagrams:

Convention (Conv.)	Description
R	Read only. Writing to this register has no effect.
W	Write only. Returns 0 when read.
R/WP	Read: Always readable. Write: Can be write-protected by password.
WP	Write only. Returns 0 when read. Can be write-protected by password.
*WP	EEPW registers: RAM mirror is Write only. Returns 0 when read. EEPROM can be READ when Unlocked
Prot.	Protected. Writing to this register has no effect.

### 3.2. REGISTER OVERVIEW

After reset, all registers are set according to Table in section REGISTER RESET VALUES SUMMARY.

#### Register Definitions; RAM, Address 00h to 3Fh:

Address	Function	Conv.	Bit 7	Bit 6	Bit 5	Bit 4	Bit 3	Bit 2	Bit 1	Bit 0
00h	Seconds	R/WP	○	40	20	10	8	4	2	1
01h	Minutes	R/WP	○	40	20	10	8	4	2	1
02h	Hours (24 hour)	R/WP	○	○	20	10	8	4	2	1
	Hours (12 hour)				AMPM	10	8	4	2	1
03h	Weekday	R/WP	○	○	○	○	○	4	2	1
04h	Date	R/WP	○	○	20	10	8	4	2	1
05h	Month	R/WP	○	○	○	10	8	4	2	1
06h	Year	R/WP	80	40	20	10	8	4	2	1
07h	Minutes Alarm	R/WP	AE_M	40	20	10	8	4	2	1
08h	Hours Alarm (24h)	R/WP	AE_H	○	20	10	8	4	2	1
	Hours Alarm (12h)				AMPM	10	8	4	2	1
09h	Weekday Alarm	R/WP	AE_WD	○	○	○	○	4	2	1
	Date Alarm				20	10	8	4	2	1
0Ah	Timer Value 0	R/WP	128	64	32	16	8	4	2	1
0Bh	Timer Value 1	R/WP	○	○	○	○	2048	1024	512	256
0Ch	Timer Status 0	R	128	64	32	16	8	4	2	1
0Dh	Timer Status 1 shadow	R	○	○	○	○	2048	1024	512	256
0Eh	Status	R/WP	EEbusy	CLKF	BSF	UF	TF	AF	EVF	PORF
0Fh	Control 1	R/WP	TRPT	-	WADA	USEL	EERD	TE	TD	
10h	Control 2	R/WP	TSE	CLKIE	UIE	TIE	AIE	EIE	12_24	RESET
11h	GP Bits	R/WP	-	GP6	GP5	GP4	GP3	GP2	GP1	GP0
12h	Clock Int. Mask	R/WP	-	-	-	-	CEIE	CAIE	CTIE	CUIE
13h	Event Control	R/WP	○	EHL	ET		○	TSR	TSOW	TSS
14h	Count TS	R	128	64	32	16	8	4	2	1
15h	Seconds TS	R	○	40	20	10	8	4	2	1
16h	Minutes TS	R	○	40	20	10	8	4	2	1
17h	Hours TS (24h)	R	○	○	20	10	8	4	2	1
	Hours TS (12h)				AMPM	10	8	4	2	1
18h	Date TS	R	○	○	20	10	8	4	2	1
19h	Month TS	R	○	○	○	10	8	4	2	1
1Ah	Year TS	R	80	40	20	10	8	4	2	1
1Bh	UNIX Time 0	R/WP	UNIX 0 [7:0]							
1Ch	UNIX Time 1	R/WP	UNIX 1 [15:8]							
1Dh	UNIX Time 2	R/WP	UNIX 2 [23:16]							
1Eh	UNIX Time 3	R/WP	UNIX 3 [31:24]							
1Fh	User RAM 1	R/WP	RAM 1 data							
20h	User RAM 2	R/WP	RAM 2 data							
21h	Password 0	W	PW 0 [7:0]							
22h	Password 1	W	PW 1 [15:8]							
23h	Password 2	W	PW 2 [23:16]							
24h	Password 3	W	PW 3 [31:24]							
25h	EE Address	R/WP	EEADDR							
26h	EE Data	R/WP	EEDATA							
27h	EE Command	WP	EECMD							
28h	ID	R	HID				VID			
29h and 2Ah	RESERVED	Prot.	RESERVED							
2Ch to 2Fh	RESERVED	Prot.	RESERVED							
38h to 3Fh	RESERVED	Prot.	RESERVED							

○ Read only. Always 0.  
- Bit not implemented. Will return a 0 when read.

**Register Definitions; Configuration EEPROM with RAM mirror, Address 2Bh and 30h to 37h:**

Address	Function	Conv.	Bit 7	Bit 6	Bit 5	Bit 4	Bit 3	Bit 2	Bit 1	Bit 0
2Bh	EEPROM Reserved	R/WP	RESERVED (Must not be overwritten)							
30h	EEPROM PW Enable	R/WP	EEPWE							
31h	EEPROM Password 0	*WP	EEPW 0 [7:0]							
32h	EEPROM Password 1	*WP	EEPW 1 [15:8]							
33h	EEPROM Password 2	*WP	EEPW 2 [23:16]							
34h	EEPROM Password 3	*WP	EEPW 3 [31:24]							
35h	EEPROM Clkout	R/WP	CLKOE	CLKSY	-	-	PORIE	FD		
36h	EEPROM Offset	R/WP	EEOffset [8:1]							
37h	EEPROM Backup	R/WP	EEOffset [0]	BSIE	TCE	FEDE	BSM		TCR	

- Bit not implemented. Will return a 0 when read.  
\* EEPW registers: RAM mirror is Write only. Returns 0 when read. EEPROM can be READ when Unlocked.

**Register Definitions; User EEPROM, Address 00h to 2Ah:**

Address	Function	Conv.	Bit 7	Bit 6	Bit 5	Bit 4	Bit 3	Bit 2	Bit 1	Bit 0
00h to 2Ah	User EEPROM (43 Bytes)	R/WP	43 Bytes of non-volatile User EEPROM							

**Register Definitions; Reserved EEPROM, Address 2Ch to 2Fh and 38h to 3Fh:**

Address	Function	Conv.	Bit 7	Bit 6	Bit 5	Bit 4	Bit 3	Bit 2	Bit 1	Bit 0
2Ch to 2Fh	Reserved EEPROM	Prot.	RESERVED							
38h to 3Fh	Reserved EEPROM	Prot.	RESERVED							

### 3.3. CLOCK REGISTERS

#### 00h – Seconds

This register holds the count of seconds, in two binary coded decimal (BCD) digits. Values will be from 00 to 59.  
Read: Always readable. Write: Can be write-protected by password.

Address	Function	Conv.	Bit 7	Bit 6	Bit 5	Bit 4	Bit 3	Bit 2	Bit 1	Bit 0
00h	Seconds	R/WP	○	40	20	10	8	4	2	1
	Reset		0	0	0	0	0	0	0	0
Bit	Symbol	Value	Description							
7	○	0	Read only. Always 0.							
6:0	Seconds	00 to 59	Holds the count of seconds, coded in BCD format. When writing to the Seconds register an eventual present memorized 1 Hz update is reset and the prescaler frequencies from 8192 Hz to 1 Hz will be reset (same effect as RESET BIT FUNCTION). When writing 1 to the RESET bit (10h) the Seconds register value remains unchanged.							

#### 01h – Minutes

This register holds the count of minutes, in two binary coded decimal (BCD) digits. Values will be from 00 to 59.  
Read: Always readable. Write: Can be write-protected by password.

Address	Function	Conv.	Bit 7	Bit 6	Bit 5	Bit 4	Bit 3	Bit 2	Bit 1	Bit 0
01h	Minutes	R/WP	○	40	20	10	8	4	2	1
	Reset		0	0	0	0	0	0	0	0
Bit	Symbol	Value	Description							
7	○	0	Read only. Always 0.							
6:0	Minutes	00 to 59	Holds the count of minutes, coded in BCD format.							

**02h – Hours**

This register holds the count of hours, in two binary coded decimal (BCD) digits. If the 12\_24 bit is cleared (default) (see STATUS AND CONTROL REGISTERS, 10h – Control 2) the values will be from 0 to 23. If the 12\_24 bit is set, the hour values will range from 1 to 12 and the AMPM bit will be 0 for AM hours and 1 for PM hours.

The value in the Hours register changes automatically between 12 and 24 hour mode when 12\_24 bit is changed.

The value in the Hours Alarm register (08h) however must be rewritten.

Read: Always readable. Write: Can be write-protected by password.

Address	Function	Conv.	Bit 7	Bit 6	Bit 5	Bit 4	Bit 3	Bit 2	Bit 1	Bit 0
02h	Hours (24 hour mode) – default value	R/WP	○	○	20	10	8	4	2	1
	Hours (12 hour mode)		○	○	AMPM	10	8	4	2	1
	Reset		0	0	0	0	0	0	0	0

**Hours (24 hour mode), 12\_24 = 0 – default value**

Bit	Symbol	Value	Description
7:6	○	0	Read only. Always 0.
5:0	Hours (24 hour mode) – default value	0 to 23	Holds the count of hours, coded in BCD format.

**Hours (12 hour mode), 12\_24 = 1**

Bit	Symbol	Value	Description
7:6	○	0	Read only. Always 0.
5	AMPM	0	AM hours.
		1	PM hours.
4:0	Hours (12 hour mode)	1 to 12	Holds the count of hours, coded in BCD format.

**Hours values:**

24 hour mode	12 hour mode	24 hour mode	12 hour mode
00	12 (AM 12)	12	32 (PM 12)
01	01 (AM 1)	13	21 (PM 1)
02	02 (AM 2)	14	22 (PM 2)
:	:	:	:
10	10 (AM 10)	22	30 (PM 10)
11	11 (AM 11)	23	31 (PM 11)

### 3.4. CALENDAR REGISTERS

#### 03h – Weekday

This register holds the current day of the week. Each value represents one weekday that is assigned by the user. Values will range from 0 to 6. The weekday counter is simply a 3-bit counter which counts up to 6 and then resets to 0.

Read: Always readable. Write: Can be write-protected by password.

Address	Function	Conv.	Bit 7	Bit 6	Bit 5	Bit 4	Bit 3	Bit 2	Bit 1	Bit 0
03h	Weekday	R/WP	○	○	○	○	○	4	2	1
	Reset		0	0	0	0	0	0	0	0
Bit	Symbol	Value	Description							
7:3	○	0	Read only. Always 0.							
2:0	Weekday	0 to 6	Holds the weekday counter value.							
Weekday			Bit 7	Bit 6	Bit 5	Bit 4	Bit 3	Bit 2	Bit 1	Bit 0
Weekday 1 – Default value			0	0	0	0	0	0	0	0
Weekday 2								0	0	1
Weekday 3								0	1	0
Weekday 4								0	1	1
Weekday 5								1	0	0
Weekday 6								1	0	1
Weekday 7								1	1	0

#### 04h – Date

This register holds the current day of the month, in two binary coded decimal (BCD) digits. Values will range from 01 to 31. Leap years are correctly handled from 2000 to 2099.

Read: Always readable. Write: Can be write-protected by password.

Address	Function	Conv.	Bit 7	Bit 6	Bit 5	Bit 4	Bit 3	Bit 2	Bit 1	Bit 0
04h	Date	R/WP	○	○	20	10	8	4	2	1
	Reset		0	0	0	0	0	0	0	1
Bit	Symbol	Value	Description							
7:6	○	0	Read only. Always 0.							
5:0	Date	01 to 31	Holds the current date of the month, coded in BCD format. – Default value = 01							



**05h – Month**

This register holds the current month, in two binary coded decimal (BCD) digits. Values will range from 01 to 12. Read: Always readable. Write: Can be write-protected by password.

Address	Function	Conv.	Bit 7	Bit 6	Bit 5	Bit 4	Bit 3	Bit 2	Bit 1	Bit 0
05h	Month	R/WP	○	○	○	10	8	4	2	1
	Reset		0	0	0	0	0	0	0	1
Bit	Symbol	Value	Description							
7:5	○	0	Read only. Always 0.							
4:0	Month	01 to 12	Holds the current month, coded in BCD format.							
Months			Bit 7	Bit 6	Bit 5	Bit 4	Bit 3	Bit 2	Bit 1	Bit 0
January – Default value			0	0	0	0	0	0	0	1
February						0	0	0	1	0
March						0	0	0	1	1
April						0	0	1	0	0
May						0	0	1	0	1
June						0	0	1	1	0
July						0	0	1	1	1
August						0	1	0	0	0
September						0	1	0	0	1
October						1	0	0	0	0
November						1	0	0	0	1
December						1	0	0	1	0

**06h – Year**

This register holds the current year, in two binary coded decimal (BCD) digits. Values will range from 00 to 99. Leap years are correctly handled from 2000 to 2099.

Read: Always readable. Write: Can be write-protected by password.

Address	Function	Conv.	Bit 7	Bit 6	Bit 5	Bit 4	Bit 3	Bit 2	Bit 1	Bit 0
06h	Year	R/WP	80	40	20	10	8	4	2	1
	Reset		0	0	0	0	0	0	0	0
Bit	Symbol	Value	Description							
7:0	Year	00 to 99	Holds the current year, coded in BCD format. – Default value = 00							

### 3.5. ALARM REGISTERS

#### 07h – Minutes Alarm

This register holds the Minutes Alarm Enable bit AE\_M and the alarm value for minutes, in two binary coded decimal (BCD) digits. Values will range from 00 to 59.

Read: Always readable. Write: Can be write-protected by password.

Address	Function	Conv.	Bit 7	Bit 6	Bit 5	Bit 4	Bit 3	Bit 2	Bit 1	Bit 0
07h	Minutes Alarm	R/WP	AE_M	40	20	10	8	4	2	1
	Reset		1	0	0	0	0	0	0	0
Bit	Symbol	Value	Description							
7	AE_M	Minutes Alarm Enable bit. Enables alarm together with AE_H and AE_WD (see USE OF THE ALARM INTERRUPT).								
		0	Minutes Alarm is enabled.							
		1	Minutes Alarm is disabled. – Default value							
6:0	Minutes Alarm	00 to 59	Holds the alarm value for minutes, coded in BCD format.							

#### 08h – Hours Alarm

This register holds the Hours Alarm Enable bit AE\_H and the alarm value for hours, in two binary coded decimal (BCD) digits. If the 12\_24 bit is cleared (default value) (see STATUS AND CONTROL REGISTERS, 10h – Control 2) the values will range from 0 to 23. If the 12\_24 bit is set, the hour values will be from 1 to 12 and the AMPM bit will be 0 for AM hours and 1 for PM hours.

If the 12\_24 hour mode bit is changed then the value in the Hours Alarm register must be re-initialized.

Read: Always readable. Write: Can be write-protected by password.

Address	Function	Conv.	Bit 7	Bit 6	Bit 5	Bit 4	Bit 3	Bit 2	Bit 1	Bit 0
08h	Hours Alarm (24 hour mode) – default value	R/WP	AE_H	○	20	10	8	4	2	1
	Hours Alarm (12 hour mode)				AMPM	10	8	4	2	1
	Reset		1	0	0	0	0	0	0	0
Hours Alarm (24 hour mode), 12_24 = 0 – default value										
Bit	Symbol	Value	Description							
7	AE_H	Hours Alarm Enable bit (see USE OF THE ALARM INTERRUPT).								
		0	Enabled							
		1	Disabled – Default value							
6	○	0	Read only. Always 0.							
5:0	Hours Alarm (24 hour mode) – default value	0 to 23	Holds the alarm value for hours, coded in BCD format.							
Hours Alarm (12 hour mode), 12_24 = 1										
Bit	Symbol	Value	Description							
7	AE_H	Hours Alarm Enable bit (see USE OF THE ALARM INTERRUPT).								
		0	Enabled							
		1	Disabled – Default value							
6	○	0	Read only. Always 0.							
5	AMPM	0	AM hours.							
		1	PM hours.							
4:0	Hours Alarm (12 hour mode)	1 to 12	Holds the alarm value for hours, coded in BCD format.							

**09h – Weekday/Date Alarm**

This register holds the Weekday/Date Alarm Enable bit AE\_WD. If the WADA bit is 0 (Bit 5 in Register 0Fh), it holds the alarm value for the weekday (weekdays assigned by the user), in two binary coded decimal (BCD) digits. Values will range from 0 to 6. If the WADA bit is 1, it holds the alarm value for the date, in two binary coded decimal (BCD) digits. Values will range from 01 to 31. Leap years are correctly handled from 2000 to 2099.

Read: Always readable. Write: Can be write-protected by password.

Address	Function	Conv.	Bit 7	Bit 6	Bit 5	Bit 4	Bit 3	Bit 2	Bit 1	Bit 0
09h	Weekday Alarm – default value	R/WP	AE_WD	○	○	○	○	4	2	1
	Date Alarm				20	10	8	4	2	1
	Reset		1	0	0	0	0	0	0	0
<b>Weekday Alarm, WADA = 0 – default value</b>										
Bit	Symbol	Value	Description							
7	AE_WD	Weekday/Date Alarm Enable bit. Enables alarm together with AE_M and AE_H (see USE OF THE ALARM INTERRUPT).								
		0	Enabled							
		1	Disabled – Default value							
6:3	○	0	Read only. Always 0.							
2:0	Weekday Alarm	0 to 6	Holds the weekday alarm value, coded in BCD format.							
<b>Date Alarm, WADA = 1</b>										
Bit	Symbol	Value	Description							
7	AE_WD	Weekday/Date Alarm Enable bit. Enables alarm together with AE_M and AE_H (see USE OF THE ALARM INTERRUPT).								
		0	Enabled							
		1	Disabled – Default value							
6	○	0	Read only. Always 0.							
5:0	Date Alarm	01 to 31	Holds the alarm value for the date, coded in BCD format. The Reset value 00 after POR has to be replaced by a valid value (01 to 31).							

### 3.6. PERIODIC COUNTDOWN TIMER CONTROL REGISTERS

#### 0Ah – Timer Value 0

This register is used to set the lower 8 bits of the 12 bit Timer Value (preset value) for the Periodic Countdown Timer. This value will be automatically reloaded into the Countdown Timer when it reaches zero if the TRPT bit is 1. This allows for periodic timer interrupts (see calculation below).

Read: Always readable. Write: Can be write-protected by password.

Address	Function	Conv.	Bit 7	Bit 6	Bit 5	Bit 4	Bit 3	Bit 2	Bit 1	Bit 0
0Ah	Timer Value 0	R/WP	128	64	32	16	8	4	2	1
	Reset		0	0	0	0	0	0	0	0
Bit	Symbol	Value	Description							
7:0	Timer Value 0	00h to FFh	The Timer Value for the Periodic Countdown Timer in binary format (lower 8 bit) (see USE OF THE PERIODIC COUNTDOWN TIMER). When read, only the preset value is returned and not the actual value. When the Periodic Countdown Timer Interrupt function is not used, register 0Ah can be used as RAM byte.							

#### 0Bh – Timer Value 1

This register is used to set the upper 4 bits of the 12 bit Timer Value (preset value) for the Periodic Countdown Timer. This value will be automatically reloaded into the Countdown Timer when it reaches zero if the TRPT bit is 1. This allows for periodic timer interrupts (see calculation below).

Read: Always readable. Write: Can be write-protected by password.

Address	Function	Conv.	Bit 7	Bit 6	Bit 5	Bit 4	Bit 3	Bit 2	Bit 1	Bit 0
0Bh	Timer Value 1	R/WP	○	○	○	○	2048	1024	512	256
	Reset		0	0	0	0	0	0	0	0
Bit	Symbol	Value	Description							
7:4	○	0	Read only. Always 0.							
3:0	Timer Value 1	0h to Fh	The Timer Value for the Periodic Countdown Timer in binary format (upper 4 bit) (see USE OF THE PERIODIC COUNTDOWN TIMER). When read, only the preset value is returned and not the actual value.							

Countdown Period in seconds:

$$\text{Countdown Period} = \frac{\text{Timer Value}}{\text{Timer Clock Frequency}}$$

**0Ch – Timer Status 0**

This register holds the lower 8 bits of the current 12 bit value of the Periodic Countdown Timer.  
Read only. Writing to this register has no effect.

Address	Function	Conv.	Bit 7	Bit 6	Bit 5	Bit 4	Bit 3	Bit 2	Bit 1	Bit 0
0Ch	Timer Status 0	R	128	64	32	16	8	4	2	1
	Reset		0	0	0	0	0	0	0	0
Bit	Symbol	Value	Description							
7:0	Timer Status 0	00h to FFh	The current value of the Periodic Countdown Timer in binary format (lower 8 bit) (see USE OF THE PERIODIC COUNTDOWN TIMER).							

**0Dh – Timer Status 1 shadow**

This register holds the upper 4 bits of the current 12 bit value of the Periodic Countdown Timer.  
Read only. Writing to this register has no effect.

Address	Function	Conv.	Bit 7	Bit 6	Bit 5	Bit 4	Bit 3	Bit 2	Bit 1	Bit 0
0Dh	Timer Status 1	R	○	○	○	○	2048	1024	512	256
	Reset		0	0	0	0	0	0	0	0
Bit	Symbol	Value	Description							
7:4	○	0	Read only. Always 0.							
3:0	Timer Status 1	0h to Fh	The current value of the Periodic Countdown Timer in binary format (upper 4 bit) (see USE OF THE PERIODIC COUNTDOWN TIMER).							

When TE bit (0Fh) is set to 1, the Timer Status 0 and Timer Status 1 shadow registers hold the current countdown value. When a 0 is written to the TE bit, the Timer Status 0 and Timer Status 1 registers store the last updated value.

Reading the Timer Status 0 value updates the Timer Status 1 shadow register. Reading only the Timer Status 1 shadow register will return the not-updated Timer Status 1 shadow register value, memorized while reading Timer Status 0.

### 3.7. STATUS AND CONTROL REGISTERS

#### 0Eh – Status

This register is used to detect the occurrence of various interrupt events and reliability problems in internal data.  
Read: Always readable. Write: Can be write-protected by password.

Address	Function	Conv.	Bit 7	Bit 6	Bit 5	Bit 4	Bit 3	Bit 2	Bit 1	Bit 0	
0Eh	Status	R/WP	EEbusy	CLKF	BSF	UF	TF	AF	EVF	PORF	
	Reset		1 → 0	0	0	0 → 1	0	0	0	1	
Bit	Symbol	Value	Description								
7	EEbusy	EEPROM Memory Busy Status Bit – (Read Only) (see EEPROM READ/WRITE)									
		0	The transfer is finished.								
		1	Indicates that the EEPROM is currently handling a read or write request and will ignore any further commands until the current one is finished. At power up (POR) a refresh is automatically generated. The time of this first refreshment is $t_{PREFR} = \sim 66$ ms. After the refreshment is finished; EEbusy is cleared to 0 automatically.								
6	CLKF	Clock Output Interrupt Flag (see PROGRAMMABLE CLOCK OUTPUT)									
		0	No event detected. When cleared to 0 the frequency output will stop depending on CLKSY and CLKOUT settings.								
		1	If set to 0 beforehand, indicates the occurrence of an interrupt driven clock output on CLKOUT pin. The value 1 is retained until a 0 is written by the user.								
5	BSF	Backup Switch Flag (see AUTOMATIC BACKUP SWITCHOVER FUNCTION)									
		0	No backup switchover detected. At power up (POR) this flag is automatically cleared to 0. When the backup switchover function is disabled (PM field = 00) BSF is always logic 0.								
		1	If set to 0 beforehand, indicates that a switchover from main power $V_{DD}$ to $V_{BACKUP}$ has occurred. The value 1 can be cleared by writing a 0 to the bit if RTC module is in VDD Power state. Caution: The EVF flag is also set by an event of the Backup Switchover function when bits TSS (13h) and TSE (10h) are set to 1.								
4	UF	Periodic Time Update Flag (see PERIODIC TIME UPDATE INTERRUPT FUNCTION)									
		0	No event detected.								
		1	If set to 0 beforehand, indicates the occurrence of a Periodic Time Update Interrupt event. The value 1 is retained until a 0 is written by the user. After power up (POR) the Second update is selected and the UF flag is set to 1 within one second.								
3	TF	Periodic Countdown Timer Flag (see PERIODIC COUNTDOWN TIMER INTERRUPT FUNCTION)									
		0	No event detected. When the $\overline{INT}$ and CLKOUT pins are LOW because of a Countdown Timer event, their $t_{RTN1}$ – signals are cancelled as soon as TF flag is cleared to 0.								
		1	If set to 0 beforehand, indicates the occurrence of a Periodic Countdown Timer Interrupt event. The value 1 is retained until a 0 is written by the user.								
2	AF	Alarm Flag (see ALARM INTERRUPT FUNCTION)									
		0	No event detected.								
		1	If set to 0 beforehand, indicates the occurrence of an Alarm Interrupt event. The value 1 is retained until a 0 is written by the user.								
1	EVF	Event Flag (see EXTERNAL EVENT INTERRUPT FUNCTION)									
		0	No event detected.								
		1	If set to 0 beforehand, indicates the occurrence of an External Event or a Backup Switchover. The value 1 is retained until a 0 is written by the user. The EVF flag is set to 1 when: <ul style="list-style-type: none"> <li>External event occurs and TSS = 0 and (EIE = 1 or TSE = 1).</li> <li>Backup switchover occurs and TSS = 1 and (EIE = 1 or TSE = 1).</li> </ul>								
0	PORF	Power On Reset Flag									
		0	No voltage drop detected.								
		1	If set to 0 beforehand, indicates a voltage drop below $V_{POR}$ . The data in the device are no longer valid and all registers must be initialized. The value 1 is retained until a 0 is written by the user. At power up (POR) the value is set to 1, the user has to write 0 to the flag to use it.								

**0Fh – Control 1**

This register is used to specify the target for the Alarm Interrupt function and the Periodic Time Update Interrupt function and to select or set operations for the Periodic Countdown Timer.

Read: Always readable. Write: Can be write-protected by password.

Address	Function	Conv.	Bit 7	Bit 6	Bit 5	Bit 4	Bit 3	Bit 2	Bit 1	Bit 0
0Fh	Control 1	R/WP	TRPT	-	WADA	USEL	EERD	TE	TD	
	Reset		0	0	0	0	0	0	0	0
Bit	Symbol	Value	Description							
7	TRPT		Timer Repeat bit. Specifies either Single or Repeat Mode for the Periodic Countdown Timer Interruption function (see PERIODIC COUNTDOWN TIMER INTERRUPT FUNCTION).							
		0	Single Mode is selected. When the Countdown Timer is enabled (TE = 1) it will halt when it reaches zero and TE is automatically cleared. – Default value							
		1	Repeat Mode is selected. When the Countdown Timer is enabled (TE = 1) it automatically reloads the value from the Timer Value registers upon reaching 0, and continues counting.							
6	-	0	Bit not implemented. Will return a 0 when read.							
5	WADA		Weekday Alarm / Date Alarm selection bit. This bit is used to specify either the Weekday or Date as the source for the Alarm Interrupt function (see ALARM INTERRUPT FUNCTION).							
		0	Weekday is the source for the Alarm Interrupt function. – Default value							
		1	Date is the source for the Alarm Interrupt function.							
4	USEL		Update Interrupt Select bit. Specifies either Second or Minute update for the Periodic Time Update Interrupt function (see PERIODIC TIME UPDATE INTERRUPT FUNCTION). Writing 1 to the RESET bit or writing to the Seconds register affects the length of the current update period (see RESET BIT FUNCTION).							
		0	Second update (Auto reset time $t_{RTN2} = 500$ ms). – Default value							
		1	Minute update (Auto reset time $t_{RTN2} = 7.813$ ms).							
3	EERD		EEPROM Memory Refresh Disable bit. When 1, disables the automatic refresh of the Configuration Registers from the EEPROM Memory (see AUTOMATIC REFRESH (ALL CONFIGURATION EEPROM → RAM)).							
		0	Refresh is active. All data in the Configuration Registers are refreshed by the data stored in the EEPROM each 24 hours, at date increment (at the beginning of the last second before midnight). The time of this automatic refreshment is $t_{REFR} = \sim 3.5$ ms. Refresh is only active when RTC is not in VBACKUP mode. – Default value							
		1	Refresh is disabled.							
2	TE		Periodic Countdown Timer Enable bit. This bit controls the start/stop setting for the Periodic Countdown Timer Interruption function (see PERIODIC COUNTDOWN TIMER INTERRUPT FUNCTION).							
		0	Stops the Periodic Countdown Timer Interrupt function. TE is also automatically cleared when Single Mode is selected (TRPT = 0) and when the Countdown Timer reaches zero. – Default value							
		1	Starts the Periodic Countdown Timer Interrupt function (a countdown starts from the preset value set in Timer Value registers).							
1:0	TD	00 to 11	Timer Clock Frequency selection. Sets the countdown source clock for the Periodic Countdown Timer Interrupt function. With this setting the Auto reset time $t_{RTN1}$ is also defined. When the clock source has been set to Second update (1 Hz) or Minute update (1/60 Hz), the timing of both, countdown and interrupts, is coordinated with the clock update timing. See table below (see also PERIODIC COUNTDOWN TIMER INTERRUPT FUNCTION). Writing 1 to the RESET bit or writing to the Seconds register affects the length of the current countdown period (see RESET BIT FUNCTION).							
TD value	Timer Clock Frequency	Countdown period	$t_{RTN1}$		Effect when writing 1 to the RESET bit or when writing to the Seconds register					
00	4096 Hz – Default value	244.14 $\mu$ s	122 $\mu$ s		Affects current period					
01	64 Hz	15.625 ms	7.813 ms							
10	1 Hz	1 s								
11	1/60 Hz	60 s								

**10h – Control 2**

This register is used to control the interrupt event output for the  $\overline{\text{INT}}$  pin, the stop/start status of clock and calendar operations, the interrupt controlled clock output on CLKOUT pin, the hour mode and the time stamp enable.

Read: Always readable. Write: Can be write-protected by password.

Address	Function	Conv.	Bit 7	Bit 6	Bit 5	Bit 4	Bit 3	Bit 2	Bit 1	Bit 0	
10h	Control 2	R/WP	TSE	CLKIE	UIE	TIE	AIE	EIE	12_24	RESET	
	Reset		0	0	0	0	0	0	0	0	
Bit	Symbol	Value	Description								
7	TSE	Time Stamp Enable bit (see TIME STAMP FUNCTION)									
		0	Disables the time stamp function. – Default value								
		1	Enables the Time stamp function.								
6	CLKIE	Interrupt Controlled Clock Output Enable bit. When enabled, it is possible to wake-up an external system by outputting a frequency. (see PROGRAMMABLE CLOCK OUTPUT)									
		0	Disabled – Default value								
		1	When set to 1, the clock output on CLKOUT pin is automatically enabled when an interrupt occurs, based on the Clock Interrupt Mask Register (12h) and according to clock setting defined by the FD field. This function is disabled in VBACKUP Power state.								
5	UIE	Periodic Time Update Interrupt Enable bit (see PERIODIC TIME UPDATE INTERRUPT FUNCTION)									
		0	No interrupt signal is generated on $\overline{\text{INT}}$ pin when a Periodic Time Update event occurs or the $t_{\text{RTN2}}$ - signal on $\overline{\text{INT}}$ pin is cancelled. – Default value								
		1	An interrupt signal is generated on $\overline{\text{INT}}$ pin when a Periodic Time Update event occurs. The low-level output signal is automatically cleared after $t_{\text{RTN2}} = 500 \text{ ms}$ (Second update) or $t_{\text{RTN2}} = 7.813 \text{ ms}$ (Minute update).								
4	TIE	Periodic Countdown Timer Interrupt Enable bit (see PERIODIC COUNTDOWN TIMER INTERRUPT FUNCTION)									
		0	No interrupt signal is generated on $\overline{\text{INT}}$ pin when a Countdown Timer event occurs or the $t_{\text{RTN1}}$ - signal on $\overline{\text{INT}}$ pin is cancelled. – Default value								
		1	An interrupt signal is generated on $\overline{\text{INT}}$ pin when a Periodic Countdown Timer event occurs. The low-level output signal is automatically cleared after $t_{\text{RTN1}} = 122 \mu\text{s}$ (TD = 00) or $t_{\text{RTN1}} = 7.813 \text{ ms}$ (TD = 01, 10, 11).								
3	AIE	Alarm Interrupt Enable bit (see ALARM INTERRUPT FUNCTION)									
		0	No interrupt signal is generated on $\overline{\text{INT}}$ pin when an Alarm event occurs or the signal is cancelled on $\overline{\text{INT}}$ pin. – Default value								
		1	An interrupt signal is generated on $\overline{\text{INT}}$ pin when an Alarm event occurs. This setting is retained until the AF flag is cleared to 0 (no automatic cancellation).								
2	EIE	Event Interrupt Enable bit (see EXTERNAL EVENT INTERRUPT FUNCTION and INTERRUPT SCHEME)									
		0	No interrupt signal is generated on $\overline{\text{INT}}$ pin when an External Event on EVI pin occurs or when an Automatic Backup Switchover occurs or the signal is cancelled on $\overline{\text{INT}}$ pin. – Default value								
		1	An interrupt signal is generated on $\overline{\text{INT}}$ pin when an External Event on EVI pin occurs and TSS = 0, or when an Automatic Backup Switchover occurs and TSS = 1. The signal on $\overline{\text{INT}}$ pin is retained until the EVF flag is cleared to 0 (no automatic cancellation).								
1	12_24	12 or 24 hour mode (see CLOCK REGISTERS and ALARM REGISTERS). The value in the Hours register changes automatically between 12 and 24 hour mode when 12_24 bit is changed. The value in the Hours Alarm register (08h) however must be rewritten.									
		0	24 hour mode is selected (0 to 23). – Default value								
		1	12 hour mode is selected (1 to 12).								
0	RESET	Reset bit. This bit is used for a software-based time adjustment (synchronization). (see RESET BIT FUNCTION).									
		0	No reset. – Default value								
		1	Resets the clock prescaler frequencies from 8192 Hz to 1 Hz (writing to the Seconds register has same effect). This bit always returns 0 when read. An eventual present memorized 1 Hz update is also reset. Because the upper stage of the prescaler is not reset (16.384 kHz) and the I <sup>2</sup> C interface is asynchronous, the first 1 Hz period after reset will be 0 to 244 $\mu\text{s}$ shorter than 1 second. Resetting the prescaler will have an influence on the length of the current clock period on all subsequent peripherals (clock and calendar, CLKOUT, timer clock, update timer clock, UNIX clock, EVI input filter).								



**11h – GP Bits**

This register holds the bits for general purpose use (7 bits).

Read: Always readable. Write: Can be write-protected by password.

Address	Function	Conv.	Bit 7	Bit 6	Bit 5	Bit 4	Bit 3	Bit 2	Bit 1	Bit 0
11h	GP Bits	R/WP	-	GP6	GP5	GP4	GP3	GP2	GP1	GP0
	Reset		0	0	0	0	0	0	0	0
Bit	Symbol	Value	Description							
7	-	0	Bit not implemented. Will return a 0 when read.							
6:0	GPx	0 or 1	Register bits for general purpose use (7 bits).							

**12h – Clock Interrupt Mask**

This register is used to select a predefined interrupt for automatic clock output. Setting a bit to 1 selects the corresponding interrupt. Multiple interrupts can be selected. After power on, no interrupt is selected (see CLOCK OUTPUT SCHEME).

Read: Always readable. Write: Can be write-protected by password.

Address	Function	Conv.	Bit 7	Bit 6	Bit 5	Bit 4	Bit 3	Bit 2	Bit 1	Bit 0
12h	Clock Interrupt Mask	R/WP	-	-	-	-	CEIE	CAIE	CTIE	CUIE
	Reset		0	0	0	0	0	0	0	0
Bit	Symbol	Value	Description							
7:4	-	0	Bit not implemented. Will return a 0 when read.							
3	CEIE	Clock output when Event Interrupt bit. The source for the Event Interrupt can be the External Event from EVI pin or the Automatic Backup Switchover (see INTERRUPT SCHEME).								
		0	Disabled – Default value							
		1	Enabled. Internal signal EI is selected.							
2	CAIE	Clock output when Alarm Interrupt bit.								
		0	Disabled – Default value							
		1	Enabled. Internal signal AI is selected.							
1	CTIE	Clock output when Periodic Countdown Timer Interrupt bit.								
		0	Disabled – Default value							
		1	Enabled: Internal signal TI is selected.							
0	CUIE	Clock output when Periodic Time Update Interrupt bit.								
		0	Disabled – Default value							
		1	Enabled. Internal signal UI is selected.							

### 3.8. EVENT CONTROL REGISTER

#### 13h – Event Control

This register controls the event detection on the EVI pin. Depending of the EHL bit, high or low level (or rising or falling edge) can be detected. Moreover a digital glitch filtering can be applied to the EVI signal by selecting a sampling period  $t_{SP}$  in the ET field. Furthermore this register holds control functions for the Time Stamp data. And the switching over to VBACKUP Power state can be selected as source for an event.

Read: Always readable. Write: Can be write-protected by password.

Address	Function	Conv.	Bit 7	Bit 6	Bit 5	Bit 4	Bit 3	Bit 2	Bit 1	Bit 0	
13h	Event Control	R/WP	○	EHL	ET		○	TSR	TSOW	TSS	
	Reset		0	0	0	0	0	0	0	0	
Bit	Symbol	Value	Description								
7	○	0	Read only. Always 0.								
6	EHL	Event High/Low Level (Rising/Falling Edge) selection for detection (see EXTERNAL EVENT INTERRUPT FUNCTION)									
		0	The falling edge (ET = 00) or low level (ET ≠ 00) is regarded as the External Event on pin EVI. – Default value								
		1	The rising edge (ET = 00) or high level (ET ≠ 00) is regarded as the External Event on pin EVI.								
5:4	ET	Event Filtering Time set. Applies a digital filtering to the EVI pin by sampling the EVI signal. (see EXTERNAL EVENT INTERRUPT FUNCTION).									
		00	No filtering. Edge detection. – Default value								
		01	Sampling period $t_{SP} = 3.9$ ms (256 Hz). Level detection.								
		10	Sampling period $t_{SP} = 15.6$ ms (64 Hz). Level detection.								
		11	Sampling period $t_{SP} = 125$ ms (8 Hz). Level detection.								
3	○	0	Read only. Always 0.								
2	TSR	Time Stamp Reset bit (see TIME STAMP FUNCTION)									
		0	Disables the Time Stamp Reset. – Default value								
		1	Resets all seven time stamp registers (Count TS to Year TS) to 00h; this bit always returns 0 when read.								
1	TSOW	Time Stamp Overwrite bit. Controls the overwrite function of the TS registers (Seconds TS to Year TS). The counter Count TS is always working, independent of the settings of the overwrite bit TSOW. (see TIME STAMP FUNCTION)									
		0	The time stamp of the first occurred event is recorded and remains in TS registers. To initialize or reinitialize the first event detection function, the EVF has to be cleared. – Default value								
		1	The time stamp of the last occurred event is recorded and TS registers are overwritten. The EVF flag does not need to be cleared.								
0	TSS	Time Stamp Source Selection bit (see TIME STAMP FUNCTION)									
		0	External Event is selected as Time Stamp source. A time stamp is generated (when TSE = 1) and an interrupt is issued (when EIE = 1) when an External Event on EVI pin occurs – Default value								
		1	Automatic Backup Switchover is selected as Time Stamp source. A time stamp is generated (when TSE = 1) and an Interrupt is issued (when BSIE = 1) when the circuit goes to VBACKUP Power state.								

### 3.9. TIME STAMP REGISTERS

Seven Time Stamp registers (Count TS to Year TS), (see TIME STAMP FUNCTION).

#### 14h – Count TS

This register contains the number of occurrences of the corresponding event in standard binary format. The values range from 0 to 255.

Read only. Writing to this register has no effect.

Address	Function	Conv.	Bit 7	Bit 6	Bit 5	Bit 4	Bit 3	Bit 2	Bit 1	Bit 0
14h	Count TS	R	128	64	32	16	8	4	2	1
	Reset		0	0	0	0	0	0	0	0
Bit	Symbol	Value	Description							
7:0	Count TS	0 to 255	Number of occurrences of the corresponding event, coded in binary. In case of an overflow the counter starts again with 00h When bit TSE = 0, the counter stops counting events. When bit TSE = 1, the counter is increased when event occurs. The counter Count TS is always working, independent of the settings of the overwrite bit TSOW. The Count TS register is reset to 00h when 1 is written to the Time Stamp Reset bit TSR (see TIME STAMP FUNCTION).							

#### 15h – Seconds TS

This register holds a recorded Time Stamp of the Seconds register, in two binary coded decimal (BCD) digits. The values are from 00 to 59.

Read only. Writing to this register has no effect.

Address	Function	Conv.	Bit 7	Bit 6	Bit 5	Bit 4	Bit 3	Bit 2	Bit 1	Bit 0
15h	Seconds TS	R	0	40	20	10	8	4	2	1
	Reset		0	0	0	0	0	0	0	0
Bit	Symbol	Value	Description							
7	0	0	Read only. Always 0.							
6:0	Seconds TS	00 to 59	Holds a recorded Time Stamp of the Seconds register, coded in BCD format. When enabled (bit TSE = 1), Depending on the setting of the TSOW bit it contains the time stamp of the first or last occurred event. The Seconds TS register is reset to 00h when 1 is written to the Time Stamp Reset bit TSR.							

#### 16h – Minutes TS

This register holds a recorded Time Stamp of the Minutes register, in two binary coded decimal (BCD) digits. The values are from 00 to 59.

Read only. Writing to this register has no effect.

Address	Function	Conv.	Bit 7	Bit 6	Bit 5	Bit 4	Bit 3	Bit 2	Bit 1	Bit 0
16h	Minutes TS	R	0	40	20	10	8	4	2	1
	Reset		0	0	0	0	0	0	0	0
Bit	Symbol	Value	Description							
7	0	0	Read only. Always 0.							
6:0	Minutes TS	00 to 59	Holds a recorded Time Stamp of the Minutes register, coded in BCD format. When enabled (bit TSE = 1), Depending on the setting of the TSOW bit it contains the time stamp of the first or last occurred event. The Minutes TS register is reset to 00h when 1 is written to the Time Stamp Reset bit TSR.							

**17h – Hours TS**

This register holds a recorded Time Stamp of the Hours register, in two binary coded decimal (BCD) digits. If the 12\_24 bit is cleared (default) (see STATUS AND CONTROL REGISTERS, 10h – Control 2) the values will be from 0 to 23. If the 12\_24 bit is set, the hour values will range from 1 to 12 and the AMPM bit will be 0 for AM hours and 1 for PM hours.

Read only. Writing to this register has no effect.

Address	Function	Conv.	Bit 7	Bit 6	Bit 5	Bit 4	Bit 3	Bit 2	Bit 1	Bit 0
17h	Hours TS (24 hour mode) – default value	R	○	○	20	10	8	4	2	1
	Hours TS (12 hour mode)		AMPM	10	8	4	2	1		
	Reset		0	0	0	0	0	0	0	0
<b>Hours TS (24 hour mode) – default value</b>										
Bit	Symbol	Value	Description							
7:6	○	0	Read only. Always 0.							
5:0	Hours TS (24 hour mode) – default value	0 to 23	Holds a recorded Time Stamp of the Hours register, coded in BCD format. When enabled (bit TSE = 1), Depending on the setting of the TSOW bit it contains the time stamp of the first or last occurred event. The Hours TS register is reset to 00h when 1 is written to the Time Stamp Reset bit TSR.							
<b>Hours TS (12 hour mode)</b>										
Bit	Symbol	Value	Description							
7:6	○	0	Read only. Always 0.							
5	AMPM	0	AM hours, from the recorded Time Stamp of the Hours register.							
		1	PM hours, from the recorded Time Stamp of the Hours register.							
4:0	Hours TS (12 hour mode)	1 to 12	Holds a recorded Time Stamp of the Hours register, coded in BCD format. When enabled (bit TSE = 1), Depending on the setting of the TSOW bit it contains the time stamp of the first or last occurred event. The Hours TS register is reset to 00h when 1 is written to the Time Stamp Reset bit TSR.							

**18h – Date TS**

This register holds a recorded Time Stamp of the Date register, in two binary coded decimal (BCD) digits. The values will range from 01 to 31.

Read only. Writing to this register has no effect.

Address	Function	Conv.	Bit 7	Bit 6	Bit 5	Bit 4	Bit 3	Bit 2	Bit 1	Bit 0
18h	Date TS	R	○	○	20	10	8	4	2	1
	Reset		0	0	0	0	0	0	0	0
Bit	Symbol	Value	Description							
7:6	○	0	Read only. Always 0.							
5:0	Date TS	01 to 31	Holds a recorded Time Stamp of the Date register, coded in BCD format. When enabled (bit TSE = 1), Depending on the setting of the TSOW bit it contains the time stamp of the first or last occurred event. The Date TS register is reset to 00h when 1 is written to the Time Stamp Reset bit TSR. After POR or when reset with TSR bit and when a Time Stamp is recorded, the value 00 will be replaced by a valid value (01 to 31).							

**19h – Month TS**

This register holds a recorded Time Stamp of the Month register, in two binary coded decimal (BCD) digits. The values will range from 01 to 12.

Read only. Writing to this register has no effect.

Address	Function	Conv.	Bit 7	Bit 6	Bit 5	Bit 4	Bit 3	Bit 2	Bit 1	Bit 0
19h	Month TS	R	○	○	○	10	8	4	2	1
	Reset		0	0	0	0	0	0	0	0
Bit	Symbol	Value	Description							
7:5	○	0	Read only. Always 0.							
4:0	Month TS	01 to 12	Holds a recorded Time Stamp of the Month register, coded in BCD format. When enabled (bit TSE = 1), Depending on the setting of the TSOW bit it contains the time stamp of the first or last occurred event. The Month TS register is reset to 00h when 1 is written to the Time Stamp Reset bit TSR. After POR or when reset with TSR bit and when a Time Stamp is recorded, the value 00 will be replaced by a valid value (01 to 12).							

**1Ah – Year TS**

This register holds a recorded Time Stamp of the Year register, in two binary coded decimal (BCD) digits. Values will range from 00 to 99.

Read only. Writing to this register has no effect.

Address	Function	Conv.	Bit 7	Bit 6	Bit 5	Bit 4	Bit 3	Bit 2	Bit 1	Bit 0
1Ah	Year TS	R	80	40	20	10	8	4	2	1
	Reset		0	0	0	0	0	0	0	0
Bit	Symbol	Value	Description							
7:0	Year TS	00 to 99	Holds a recorded Time Stamp of the Year register, coded in BCD format. When enabled (bit TSE = 1), Depending on the setting of the TSOW bit it contains the time stamp of the first or last occurred event. The Year TS register is reset to 00h when 1 is written to the Time Stamp Reset bit TSR.							

### 3.10. UNIX TIME REGISTERS

The UNIX Time counter is a 32-bit counter with the value in binary format. The counter will roll-over to 00000000h when reaching FFFFFFFFh. The 4 counter registers are fully readable and writable. The counter source clock is the digitally offset compensated 1 Hz clock frequency. The UNIX Time counter increment is inhibited during I<sup>2</sup>C write access to the 4 UNIX Time registers to allow coherent data values (see UNIX TIME COUNTER and SETTING AND READING THE TIME).

Read: Always readable. Write: Can be write-protected by password.

#### 1Bh – UNIX Time 0

Bit 0 to 7 from 32-bit UNIX Time counter.

Address	Function	Conv.	Bit 7	Bit 6	Bit 5	Bit 4	Bit 3	Bit 2	Bit 1	Bit 0
1Bh	UNIX Time 0	R/WP	UNIX 0 [7:0]							
	Reset		0	0	0	0	0	0	0	0
Bit	Symbol	Value	Description							
7:0	UNIX 0 [7:0]	00h to FFh	Bit 0 to 7 from 32-bit UNIX counter.							

#### 1Ch – UNIX Time 1

Bit 8 to 15 from 32-bit UNIX Time counter.

Address	Function	Conv.	Bit 7	Bit 6	Bit 5	Bit 4	Bit 3	Bit 2	Bit 1	Bit 0
1Ch	UNIX Time 1	R/WP	UNIX 1 [15:8]							
	Reset		0	0	0	0	0	0	0	0
Bit	Symbol	Value	Description							
7:0	UNIX 1 [15:8]	00h to FFh	Bit 8 to 15 from 32-bit UNIX counter.							

#### 1Dh – UNIX Time 2

Bit 16 to 23 from 32-bit UNIX Time counter.

Address	Function	Conv.	Bit 7	Bit 6	Bit 5	Bit 4	Bit 3	Bit 2	Bit 1	Bit 0
1Dh	UNIX Time 2	R/WP	UNIX 2 [23:16]							
	Reset		0	0	0	0	0	0	0	0
Bit	Symbol	Value	Description							
7:0	UNIX 2 [23:16]	00h to FFh	Bit 16 to 23 from 32-bit UNIX counter.							

#### 1Eh – UNIX Time 3

Bit 24 to 31 from 32-bit UNIX Time counter.

Address	Function	Conv.	Bit 7	Bit 6	Bit 5	Bit 4	Bit 3	Bit 2	Bit 1	Bit 0
1Eh	UNIX Time 3	R/WP	UNIX 3 [31:24]							
	Reset		0	0	0	0	0	0	0	0
Bit	Symbol	Value	Description							
7:0	UNIX 3 [31:24]	00h to FFh	Bit 24 to 31 from 32-bit UNIX counter.							

### 3.11. RAM REGISTERS

Two free RAM bytes, which can be used for any purpose, for example, status bytes of the system.

#### 1Fh – User RAM 1

This register holds the bits for general purpose use.

Read: Always readable. Write: Can be write-protected by password.

Address	Function	Conv.	Bit 7	Bit 6	Bit 5	Bit 4	Bit 3	Bit 2	Bit 1	Bit 0
1Fh	User RAM 1	R/WP	RAM 1							
	Reset		0	0	0	0	0	0	0	0
Bit	Symbol	Value	Description							
7:0	RAM 1	00h to FFh	RAM 1 data							

#### 20h – User RAM 2

This register holds the bits for general purpose use.

Read: Always readable. Write: Can be write-protected by password.

Address	Function	Conv.	Bit 7	Bit 6	Bit 5	Bit 4	Bit 3	Bit 2	Bit 1	Bit 0
20h	User RAM 2	R/WP	RAM 2							
	Reset		0	0	0	0	0	0	0	0
Bit	Symbol	Value	Description							
7:0	RAM 2	00h to FFh	RAM 2 data							

### 3.12. PASSWORD REGISTERS

After a Power up and the first refreshment time  $t_{\text{PREFR}} = \sim 66$  ms, the PW 0 to PW 3 registers are reset to 00h. When enabled by writing 255 into the EEPROM Password Enable register EEPWE (EEPROM 30h) the Password registers are used to be written with the 32-Bit Password necessary to be able to write in all writable registers (time, control and configuration registers). This 32-Bit Password is compared to the 32 bits stored in the RAM mirror of the EEPROM Password registers EEPW 0 to EEPW 3 (EEPROM 31h to 34h) (see EEPROM PASSWORD REGISTERS).

#### 21h – Password 0

Bit 0 to 7 from 32-bit Password.  
Write only. Returns 0 when read.

Address	Function	Conv.	Bit 7	Bit 6	Bit 5	Bit 4	Bit 3	Bit 2	Bit 1	Bit 0
21h	Password 0	W	PW 0 [7:0]							
	Reset		0	0	0	0	0	0	0	0
Bit	Symbol	Value	Description							
7:0	PW 0 [7:0]	00h to FFh	Bit 0 to 7 from 32-bit Password							

#### 22h – Password 1

Bit 8 to 15 from 32-bit Password.  
Write only. Returns 0 when read.

Address	Function	Conv.	Bit 7	Bit 6	Bit 5	Bit 4	Bit 3	Bit 2	Bit 1	Bit 0
22h	Password 1	W	PW 1 [15:8]							
	Reset		0	0	0	0	0	0	0	0
Bit	Symbol	Value	Description							
7:0	PW 1 [15:8]	00h to FFh	Bit 8 to 15 from 32-bit Password							

#### 23h – Password 2

Bit 16 to 23 from 32-bit Password.  
Write only. Returns 0 when read.

Address	Function	Conv.	Bit 7	Bit 6	Bit 5	Bit 4	Bit 3	Bit 2	Bit 1	Bit 0
23h	Password 2	W	PW 2 [23:16]							
	Reset		0	0	0	0	0	0	0	0
Bit	Symbol	Value	Description							
7:0	PW 2 [23:16]	00h to FFh	Bit 16 to 23 from 32-bit Password							

#### 24h – Password 3

Bit 24 to 31 from 32-bit Password.  
Write only. Returns 0 when read.

Address	Function	Conv.	Bit 7	Bit 6	Bit 5	Bit 4	Bit 3	Bit 2	Bit 1	Bit 0
24h	Password 3	W	PW 3 [31:24]							
	Reset		0	0	0	0	0	0	0	0
Bit	Symbol	Value	Description							
7:0	PW 3 [31:24]	00h to FFh	Bit 24 to 31 from 32-bit Password							



### 3.13. EEPROM MEMORY CONTROL REGISTERS

See also EEPROM READ/WRITE.

#### 25h – EE Address

This register holds the Address used for read or write from/to a single EEPROM Memory byte.

Read: Always readable. Write: Can be write-protected by password.

Address	Function	Conv.	Bit 7	Bit 6	Bit 5	Bit 4	Bit 3	Bit 2	Bit 1	Bit 0
25h	EE Address	R/WP	EEADDR							
	Reset		0	0	0	0	0	0	0	0
Bit	Symbol	Value	Description							
7:0	EEADDR	00h to FFh	Address for direct read or write one EEPROM Memory byte.							

#### 26h – EE Data

This register holds the Data that are read from, or that are written to a single EEPROM Memory byte.

Read: Always readable. Write: Can be write-protected by password.

Address	Function	Conv.	Bit 7	Bit 6	Bit 5	Bit 4	Bit 3	Bit 2	Bit 1	Bit 0
26h	EE Data	R/WP	EEDATA							
	Reset		X	X	X	X	X	X	X	X
Bit	Symbol	Value	Description							
7:0	EEDATA	00h to FFh	Data from direct read or for direct write to one EEPROM Memory byte.							

**27h – EE Command**

This register must be written with specific values, in order to Update or Refresh all (readable/writeable) Configuration EEPROM registers or to read or write from/to a single EEPROM Memory byte.

Before using this commands, the automatic refresh function has to be disabled (EERD = 1) and the busy status bit EEbusy has to indicate, that the last transfer has been finished (EEbusy = 0). Before entering the command 11h, 12h, 21h or 22h, EECMD has to be written with 00h.

Write only. Can be write-protected by password.

Address	Function	Conv.	Bit 7	Bit 6	Bit 5	Bit 4	Bit 3	Bit 2	Bit 1	Bit 0
27h	EE Command	WP	EECMD							
	Reset		0	0	0	0	0	0	0	0
Bit	Symbol	Value	Description							
7:0	EECMD		Commands for EEPROM Memory (see EEPROM READ/WRITE)							
		00h	First command must be 00h. – Default value							
		11h	UPDATE (ALL CONFIGURATION RAM → EEPROM). When writing a value of 11h, data from all Configuration RAM mirror bytes (address 30h to 37h) are written (stored) into the corresponding Configuration EEPROM bytes. See also USE OF THE CONFIGURATION REGISTERS.							
		12h	REFRESH (ALL CONFIGURATION EEPROM → RAM). When writing a value of 12h, data from all Configuration EEPROM bytes are read and copied into the corresponding Configuration RAM mirror bytes (address 30h to 37h). Functions become active as soon as the RAM bytes are written.							
		21h	WRITE TO ONE EEPROM BYTE (EEDATA (RAM) → EEPROM). When writing a value of 21h, data from the EEDATA (RAM) byte are written (stored) into the EEPROM byte with the address specified in the EEADDR byte. For Configuration EEPROM (address 30h to 37h) and User EEPROM (address 00h to 2Ah).							
		22h	READ ONE EEPROM BYTE (EEPROM → EEDATA (RAM)). When writing a value of 22h, data from the EEPROM byte with the address specified in EEADDR byte are read and copied into the EEDATA (RAM) byte. For Configuration EEPROM (address 30h to 37h) and User EEPROM (address 00h to 2Ah).							

### 3.14. ID REGISTER

#### 28h – ID

This register holds the 4 bit Hardware Identification number (HID) and the 4 bit Version Identification number (VID). The ID can be used to monitor a hardware modification and the version in the production line. Read only. Writing to this register has no effect.

Address	Function	Conv.	Bit 7	Bit 6	Bit 5	Bit 4	Bit 3	Bit 2	Bit 1	Bit 0
28h	ID	R	HID				VID			
	Reset		Preconfigured Value				Preconfigured Value			
Bit	Symbol	Value	Description							
7:4	HID	0 to 15	Hardware Identification number.							
3:0	VID	0 to 15	Version Identification number.							

### 3.15. CONFIGURATION EEPROM WITH RAM MIRROR REGISTERS

All Configuration EEPROM at addresses 2Bh and 30h to 37h are memorized in the EEPROM and mirrored in the RAM. Functions become active as soon as the RAM mirror bytes are written. See also USE OF THE CONFIGURATION REGISTERS.

#### 3.15.1. EEPROM RESERVED

##### 2Bh – EEPROM RESERVED

This preconfigured (Factory Calibrated) value must not be overwritten. Read: Always readable. Write: Can be write-protected by password.

Address	Function	Conv.	Bit 7	Bit 6	Bit 5	Bit 4	Bit 3	Bit 2	Bit 1	Bit 0
2Bh	EEPROM Reserved	R/WP	RESERVED (Must not be overwritten)							
	Default value on delivery		Preconfigured (Factory Calibrated)							
Bit	Symbol	Value	Description							
7:0	RESERVED		Preconfigured (Factory Calibrated) – Must not be overwritten.							

#### 3.15.2. EEPROM PASSWORD ENABLE REGISTER

After a Power up and the first refreshment time  $t_{PREFR} = \sim 66$  ms, the Password Enable value EEPWE is copied from the EEPROM to the corresponding RAM mirror. The default value preset on delivery is 00h.

##### 30h – EEPROM Password Enable

Read: Always readable. Write: Can be write-protected by password.

Address	Function	Conv.	Bit 7	Bit 6	Bit 5	Bit 4	Bit 3	Bit 2	Bit 1	Bit 0
30h	EEPROM Password Enable	R/WP	EEPWE							
	Default value on delivery		0	0	0	0	0	0	0	0
Bit	Symbol	Value	Description							
7:0	EEPWE		EEPROM Password Enable							
		0 to 254	Password function disabled. When writing a value not equal 255, the password function is disabled. – 00h is the default value preset on delivery							
		255	Password function enabled. When writing a value of 255, the Password registers (21h to 24h) can be used to enter the 32-bit Password.							

### 3.15.3. EEPROM PASSWORD REGISTERS

After a Power up and the first refreshment time  $t_{PREFR} = \sim 66$  ms, the EEPROM Password values EEPROM 0 to EEPROM 3 are copied from the EEPROM to the corresponding RAM mirror. The default values preset on delivery are 00h.

#### 31h – EEPROM Password 0

Bit 0 to 7 from 32-bit EEPROM Password.

Write only. Can be write-protected by password.

Address	Function	Conv.	Bit 7	Bit 6	Bit 5	Bit 4	Bit 3	Bit 2	Bit 1	Bit 0
31h	EEPROM Password 0	*WP	EEPW 0 [7:0]							
	Default value on delivery		0	0	0	0	0	0	0	0
Bit	Symbol	Value	Description							
7:0	EEPW 0 [7:0]	00h to FFh	Bit 0 to 7 from 32-bit EEPROM Password							

\* EEPROM registers: RAM mirror is Write only. Returns 0 when read. EEPROM can be READ when Unlocked.

#### 32h – EEPROM Password 1

Bit 8 to 15 from 32-bit EEPROM Password.

Write only. Can be write-protected by password.

Address	Function	Conv.	Bit 7	Bit 6	Bit 5	Bit 4	Bit 3	Bit 2	Bit 1	Bit 0
32h	EEPROM Password 1	*WP	EEPW 1 [15:8]							
	Default value on delivery		0	0	0	0	0	0	0	0
Bit	Symbol	Value	Description							
7:0	EEPW 1 [15:8]	00h to FFh	Bit 8 to 15 from 32-bit EEPROM Password							

\* EEPROM registers: RAM mirror is Write only. Returns 0 when read. EEPROM can be READ when Unlocked.

#### 33h – EEPROM Password 2

Bit 16 to 23 from 32-bit EEPROM Password.

Write only. Can be write-protected by password.

Address	Function	Conv.	Bit 7	Bit 6	Bit 5	Bit 4	Bit 3	Bit 2	Bit 1	Bit 0
33h	EEPROM Password 2	*WP	EEPW 2 [23:16]							
	Default value on delivery		0	0	0	0	0	0	0	0
Bit	Symbol	Value	Description							
7:0	EEPW 2 [23:16]	00h to FFh	Bit 16 to 23 from 32-bit EEPROM Password							

\* EEPROM registers: RAM mirror is Write only. Returns 0 when read. EEPROM can be READ when Unlocked.

#### 34h – EEPROM Password 3

Bit 24 to 31 from 32-bit EEPROM Password.

Write only. Can be write-protected by password.

Address	Function	Conv.	Bit 7	Bit 6	Bit 5	Bit 4	Bit 3	Bit 2	Bit 1	Bit 0
34h	EEPROM Password 3	*WP	EEPW 3 [31:24]							
	Default value on delivery		0	0	0	0	0	0	0	0
Bit	Symbol	Value	Description							
7:0	EEPW 3 [31:24]	00h to FFh	Bit 24 to 31 from 32-bit EEPROM Password							

\* EEPROM registers: RAM mirror is Write only. Returns 0 when read. EEPROM can be READ when Unlocked.

## 3.15.4. EEPROM CLKOUT REGISTER

## 35h – EEPROM Clkout

A programmable square wave output is available at CLKOUT pin. Operation is enabled by the CLKOE bit (see PROGRAMMABLE CLOCK OUTPUT). After a Power up and the first refreshment time  $t_{PREFR} = \sim 66$  ms, the EEPROM Clkout values CLKOE, CLKS Y, PORIE and FD are copied from the EEPROM to the corresponding RAM mirror. The default values preset on delivery are: CLKOUT = enabled, synchronization enabled, F = 32.768 kHz. Read: Always readable. Write: Can be write-protected by password.

Address	Function	Conv.	Bit 7	Bit 6	Bit 5	Bit 4	Bit 3	Bit 2	Bit 1	Bit 0	
35h	EEPROM Clkout	R/WP	CLKOE	CLKSY	-	-	PORIE	FD			
	Default value on delivery		1	1	0	0	0	0	0	0	
Bit	Symbol	Value	Description								
7	CLKOE	CLKOUT Enable bit (see PROGRAMMABLE CLOCK OUTPUT)									
		0	The CLKOUT pin is LOW.								
		1	The clock output signal on CLKOUT pin is enabled. – Default value on delivery								
6	CLKSY	CLKOUT Synchronized enable/disable (see SYNCHRONIZED ENABLE/DISABLE)									
		0	Disabled								
		1	Enables the Synchronized enable/disable (by CLKOE) of the CLKOUT frequency. – Default value on delivery								
5:4	-	0	Bit not implemented. Will return a 0 when read.								
3	PORIE	Power On Reset Interrupt Enable bit (see POWER ON RESET INTERRUPT FUNCTION)									
		0	No interrupt signal is generated on $\overline{INT}$ pin when a Power On Reset occurs or the signal is cancelled on $\overline{INT}$ pin. – Default value on delivery								
		1	An interrupt signal is generated on $\overline{INT}$ pin when a Power On Reset occurs. This setting is retained until the PORF flag is cleared to 0 (no automatic cancellation).								
2:0	FD	000 to 111	CLKOUT Frequency Selection (see CLKOUT FREQUENCY SELECTION)								
FD value	CLKOUT Frequency Selection		Effect when writing 1 to the RESET bit or when writing to the Seconds register								
000	32.768 kHz – Default value on delivery		No effect								
001	8192 Hz <sup>(1)</sup>		Affects current period								
010	1024 Hz <sup>(1)</sup>		Affects current period								
011	64 Hz <sup>(1)</sup>		Affects current period								
100	32 Hz <sup>(1)</sup>		Affects current period								
101	1 Hz <sup>(1)</sup>		Affects current period								
110	Predefined periodic countdown timer interrupt <sup>(1)</sup> <sup>(2)</sup>		Affects current period								
111	CLKOUT = LOW		No effect								
<sup>(1)</sup> 8192 Hz to 1 Hz clock pulses and the timer interrupt pulses can be affected by compensation pulses (see FREQUENCY OFFSET CORRECTION). <sup>(2)</sup> CLKS Y bit has no effect.											

### 3.15.5. EEPROM OFFSET REGISTER

The registers EEPROM Offset and EEPROM Backup hold the EEOffset value to digitally compensate the initial frequency deviation of the 32.768 kHz oscillator or for aging adjustment. EEOffset defines correction pulses in steps. Each pulse introduces a deviation of 0.9537 ppm, the maximum range is from +243.2 ppm to -244.1 ppm. The value of 0.9537 ppm is based on a nominal 32.768 kHz clock (see FREQUENCY OFFSET CORRECTION). The preconfigured (Factory Calibrated) EEOffset value may be changed by the user.

#### 36h – EEPROM Offset

This register holds the upper 8 bits of the EEOffset value. The preconfigured (Factory Calibrated) EEOffset value may be changed by the user. The least significant bit (LSB) of the EEOffset value is located in register EEPROM Backup (37h) (see also EEPROM BACKUP REGISTER).

After a Power up and the first refreshment time  $t_{PREFR} = \sim 66$  ms, the EEPROM Offset value is copied from the EEPROM to the corresponding RAM mirror.

Read: Always readable. Write: Can be write-protected by password.

Address	Function	Conv.	Bit 7	Bit 6	Bit 5	Bit 4	Bit 3	Bit 2	Bit 1	Bit 0
36h	EEPROM Offset	R/WP	EEOffset [8:1]							
	Default value on delivery		Preconfigured (Factory Calibrated)							
<b>Bit</b>	<b>Symbol</b>	<b>Value</b>	<b>Description</b>							
7:0	EEOffset [8:1]	00h to FFh	Upper 8 bits of the EEOffset value. See table below.							

Address	Function	Conv.	Bit 7	Bit 6	Bit 5	Bit 4	Bit 3	Bit 2	Bit 1	Bit 0
37h	EEPROM Backup	R/WP	EEOffset [0]	BSIE	TCE	FEDE	BSM		TCR	
	Default value on delivery		Preconfigured	0	0	1	0	0	0	0
<b>Bit</b>	<b>Symbol</b>	<b>Value</b>	<b>Description</b>							
7	EEOffset [0]	0 or 1	LSB of the EEOffset value. See table below.							

EEOffset (9 bits):

EEOffset [8:0]	EEOffset correction value in decimal	Correction pulses in steps	CLKOUT frequency correction in ppm <sup>(*)</sup>
01111111	255	255	243.187
01111110	254	254	242.233
:	:	:	:
00000001	1	1	0.954
00000000	0	0	0.000
11111111	511	-1	-0.954
11111110	510	-2	-1.907
:	:	:	:
10000001	257	-255	-243.187
10000000	256	-256	-244.141

(\*) Each correction pulse corresponds to  $1 / (16384 \times 64) = 0.9537$  ppm.

The frequency deviation measured at CLKOUT pin can be compensated by computing the correction value EEOffset and writing it into the EEPROM Offset and EEPROM Backup registers (see FREQUENCY OFFSET CORRECTION).

## 3.15.6. EEPROM BACKUP REGISTER

## 37h – EEPROM Backup

This register is used to control the switchover function and the trickle charger and it holds bit 0 (LSB) of the EEOffset value. The preconfigured (Factory Calibrated) EEOffset value may be changed by the user.

After a Power up and the first refreshment time  $t_{PREFR} = \sim 66$  ms, the EEPROM Backup value is copied from the EEPROM to the corresponding RAM mirror.

Read: Always readable. Write: Can be write-protected by password.

Address	Function	Conv.	Bit 7	Bit 6	Bit 5	Bit 4	Bit 3	Bit 2	Bit 1	Bit 0
37h	EEPROM Backup	R/WP	EEOffset [0]	BSIE	TCE	FEDE	BSM		TCR	
	Default value on delivery		Preconfigured	0	0	1	0	0	0	0
Bit	Symbol	Value	Description							
7	EEOffset [0]	0 to 1	LSB of the EEOffset value (see EEPROM OFFSET REGISTER).							
6	BSIE	Backup Switchover Interrupt Enable bit (see AUTOMATIC BACKUP SWITCHOVER FUNCTION and AUTOMATIC BACKUP SWITCHOVER INTERRUPT FUNCTION)								
		0	No interrupt signal is generated on $\overline{INT}$ pin when an Automatic Backup Switchover occurs or the signal is cancelled on $\overline{INT}$ pin. – Default value on delivery							
		1	An interrupt signal is generated on $\overline{INT}$ pin when an Automatic Backup Switchover occurs. This setting is retained until the BSF flag is cleared to 0 (no automatic cancellation).							
5	TCE	Trickle Charger Enable bit (see TRICKLE CHARGER)								
		0	Disabled – Default value on delivery							
1		Enabled								
		4	FEDE	Fast Edge Detection Enable bit (see AUTOMATIC BACKUP SWITCHOVER FUNCTION and AUTOMATIC BACKUP SWITCHOVER INTERRUPT FUNCTION)						
0	Disabled.									
1	FEDE should always be set to 1. When the FEDE bit is 1, the Fast Edge Detection for the Automatic Backup Switchover function is enabled. A voltage on $V_{DD}$ power supply pin with an increasing or falling edge with a slew rate typically greater than 7 V/ms can be correctly detected and the Automatic Backup Switchover function is adapted to this particular situation. – Default value on delivery									
3:2	BSM	Backup Switchover Mode (see AUTOMATIC BACKUP SWITCHOVER FUNCTION and AUTOMATIC BACKUP SWITCHOVER INTERRUPT FUNCTION) To read/write from/to the EEPROM, the user has to disable the Backup Switchover function by setting the BSM field to 00 or 10 (see routine in EEPROM READ/WRITE CONDITIONS)								
		00	Switchover Disabled. – Default value on delivery							
		01	Enables the Direct Switching Mode (DSM). Switchover when $V_{DD} < V_{BACKUP-}$ .							
		10	Switchover Disabled.							
		11	Enables the Level Switching Mode (LSM). Switchover when $V_{DD} < V_{TH,LSM}$ (2.0 V) AND $V_{BACKUP} > V_{TH,LSM}$ (2.0 V).							
1:0	TCR	Trickle Charger Series Resistance (see TRICKLE CHARGER)								
		00	TCR 3 k $\Omega$ – Default value on delivery							
		01	TCR 5 k $\Omega$							
		10	TCR 9 k $\Omega$							
		11	TCR 15 k $\Omega$							

### 3.16. USER EEPROM

#### 00h – 2Ah – User EEPROM

43 Bytes of User EEPROM for general purpose storage are provided.

Read: Always readable. Write: Can be write-protected by password.

Address	Function	Conv.	Bit 7	Bit 6	Bit 5	Bit 4	Bit 3	Bit 2	Bit 1	Bit 0
00h to 2Ah	User EEPROM	R/WP	43 Bytes of non-volatile User EEPROM							

### 3.17. RESERVED EEPROM

#### 2Ch – 2Fh and 38h – 3Fh – Reserved EEPROM

Protected. Writing to this register has no effect.

Address	Function	Conv.	Bit 7	Bit 6	Bit 5	Bit 4	Bit 3	Bit 2	Bit 1	Bit 0
2Ch to 2Fh	Reserved EEPROM	Prot.	RESERVED							
38h to 3Fh	Reserved EEPROM	Prot.	RESERVED							



## 3.18. REGISTER RESET VALUES SUMMARY

Reset values; RAM, Address 00h to 3Fh:

Address	Function	Conv.	Bit 7	Bit 6	Bit 5	Bit 4	Bit 3	Bit 2	Bit 1	Bit 0
00h	Seconds	R/WP	0	0	0	0	0	0	0	0
01h	Minutes	R/WP	0	0	0	0	0	0	0	0
02h	Hours (24h / 12h)	R/WP	0	0	0	0	0	0	0	0
03h	Weekday	R/WP	0	0	0	0	0	0	0	0
04h	Date	R/WP	0	0	0	0	0	0	0	1
05h	Month	R/WP	0	0	0	0	0	0	0	1
06h	Year	R/WP	0	0	0	0	0	0	0	0
07h	Minutes Alarm	R/WP	1	0	0	0	0	0	0	0
08h	Hours Alarm (24h / 12h)	R/WP	1	0	0	0	0	0	0	0
09h	Weekday Alarm / Date Alarm	R/WP	1	0	0	0	0	0	0	0
0Ah	Timer Value 0	R/WP	0	0	0	0	0	0	0	0
0Bh	Timer Value 1	R/WP	0	0	0	0	0	0	0	0
0Ch	Timer Status 0	R	0	0	0	0	0	0	0	0
0Dh	Timer Status 1 shadow	R	0	0	0	0	0	0	0	0
0Eh	Status	R/WP	1 → 0	0	0	0 → 1	0	0	0	1
0Fh	Control 1	R/WP	0	0	0	0	0	0	0	0
10h	Control 2	R/WP	0	0	0	0	0	0	0	0
11h	GP Bits	R/WP	0	0	0	0	0	0	0	0
12h	Clock Int. Mask	R/WP	0	0	0	0	0	0	0	0
13h	Event Control	R/WP	0	0	0	0	0	0	0	0
14h	Count TS	R	0	0	0	0	0	0	0	0
15h	Seconds TS	R	0	0	0	0	0	0	0	0
16h	Minutes TS	R	0	0	0	0	0	0	0	0
17h	Hours TS (24h / 12h)	R	0	0	0	0	0	0	0	0
18h	Date TS	R	0	0	0	0	0	0	0	0
19h	Month TS	R	0	0	0	0	0	0	0	0
1Ah	Year TS	R	0	0	0	0	0	0	0	0
1Bh	UNIX Time 0	R/WP	0	0	0	0	0	0	0	0
1Ch	UNIX Time 1	R/WP	0	0	0	0	0	0	0	0
1Dh	UNIX Time 2	R/WP	0	0	0	0	0	0	0	0
1Eh	UNIX Time 3	R/WP	0	0	0	0	0	0	0	0
1Fh	User RAM 1	R/WP	0	0	0	0	0	0	0	0
20h	User RAM 2	R/WP	0	0	0	0	0	0	0	0
21h	Password 1	W	0	0	0	0	0	0	0	0
22h	Password 2	W	0	0	0	0	0	0	0	0
23h	Password 3	W	0	0	0	0	0	0	0	0
24h	Password 4	W	0	0	0	0	0	0	0	0
25h	EE Address	R/WP	0	0	0	0	0	0	0	0
26h	EE Data	R/WP	X	X	X	X	X	X	X	X
27h	EE Command	WP	0	0	0	0	0	0	0	0
28h	ID	R	Preconfigured Value				Preconfigured Value			
29h and 2Ah	RESERVED	Prot.	XXh							
2Ch to 2Fh	RESERVED	Prot.	XXh							
38h to 3Fh	RESERVED	Prot.	XXh							

X = not defined

Default values on delivery; **Configuration EEPROM** with RAM mirror, Address 2Bh and 30h to 37h:

Address	Function	Conv.	Bit 7	Bit 6	Bit 5	Bit 4	Bit 3	Bit 2	Bit 1	Bit 0
2Bh	EEPROM Reserved	R/WP	Preconfigured (Factory Calibrated) – Must not be overwritten.							
30h	EEPROM PW Enable	R/WP	0	0	0	0	0	0	0	0
31h	EEPROM Password 0	WP	0	0	0	0	0	0	0	0
32h	EEPROM Password 1	WP	0	0	0	0	0	0	0	0
33h	EEPROM Password 2	WP	0	0	0	0	0	0	0	0
34h	EEPROM Password 3	WP	0	0	0	0	0	0	0	0
35h	EEPROM Clkout	R/WP	1	1	0	0	0	0	0	0
36h	EEPROM Offset	R/WP	0	0	0	0	0	0	0	0
37h	EEPROM Backup	R/WP	0	0	0	1	0	0	0	0

Default values on delivery; **User EEPROM**, Address 00h to 2Ah:

Address	Function	Conv.	Bit 7	Bit 6	Bit 5	Bit 4	Bit 3	Bit 2	Bit 1	Bit 0
00h to 2Ah	User EEPROM (43 Bytes)	R/WP	00h							

Default values on delivery; **Reserved EEPROM**, Address 2Ch to 2Fh and 38h to 3Fh:

Address	Function	Conv.	Bit 7	Bit 6	Bit 5	Bit 4	Bit 3	Bit 2	Bit 1	Bit 0
2Ch to 2Fh	Reserved EEPROM	Prot.	XXh							
38h to 3Fh	Reserved EEPROM	Prot.	XXh							
X = not defined										

RV-3028-C7 reset values after power on (RAM) and default values on delivery (EEPROM):

**RAM, reset values:**

Time (hh:mm:ss)	=	00:00:00
Date (YY-MM-DD)	=	00-01-01
Weekday	=	0
Hour mode	=	24 hour mode (0 to 23)
Count TS	=	0 (read only)
Time TS (hh:mm:ss)	=	00:00:00 (read only)
Date TS (YY-MM-DD)	=	00-00-00 (read only)
UNIX Time	=	00000000h
Alarm function	=	disabled, weekday is selected
Timer function	=	disabled, Timer Clock Frequency = 4096 Hz, Single Mode selected
Update function	=	Second update is selected
External Event function	=	Falling edge is regarded as External Event on pin EVI, first event is recorded
Time Stamp function	=	disabled, External Event selected, Time Stamp overwrite disabled, Time Stamp Reset disabled
EEPROM Memory Refresh	=	enabled
Interrupts	=	disabled
EEbusy status bit	=	1 → 0 (1 for the time $t_{PREFR} = \sim 66$ ms, then it is cleared to 0 automatically)
UF Flag	=	0 → 1 (Second update is selected)
EVF Flag	=	0
PORF Flag	=	1 (can be cleared by writing 0 to the bit)
Int. Controlled Clock	=	disabled, no interrupt selected
Password	=	00000000h (write only)
EE Address	=	00h
EE Data	=	XXh
EE Command	=	00h (first command) (write only)
ID	=	Preconfigured Value (read only)
General Purpose Bits	=	0 (7 bits)
User RAM 1, 2	=	00h (2 bytes)

**Configuration EEPROM with RAM mirror, default values on delivery:**

EEPROM Reserved (2Bh)	=	Preconfigured Value – Must not be overwritten
EEPROM Password Enable	=	disabled
EEPROM Password	=	00000000h (write only)
CLKOUT	=	enabled, synchronization enabled, F = 32.768 kHz
Power On Reset Interrupt	=	disabled
EEOffset value	=	Preconfigured Value (9 bits) (may be changed by the user)
Backup Switchover	=	disabled, interrupt disabled, Fast Edge Detection enabled
Trickle charger	=	disabled, TCR 3 kΩ is selected

**User EEPROM, default values on delivery:**

User EEPROM (43 Bytes)	=	00h
------------------------	---	-----

**Reserved EEPROM, Address 2Ch to 2Fh and 38h to 3Fh, default values on delivery:**

Reserved EEPROM	=	XXh (protected)
-----------------	---	-----------------

## 4. DETAILED FUNCTIONAL DESCRIPTION

### 4.1. POWER ON RESET (POR)

The power on reset (POR) is generated at start-up (see POWER ON AC ELECTRICAL CHARACTERISTICS). All RAM registers including the Counter Registers are initialized to their reset values and the Configuration EEPROM registers with the RAM mirror registers are set to their preset default values. At power up a refresh of the RAM mirror values by the values in the Configuration EEPROM is automatically generated. The time of this first refreshment is  $t_{\text{PREFR}} = \sim 66$  ms. The EEBusy bit in the Status register (0Eh) can be used to monitor the status of the refreshment (see REGISTER RESET VALUES SUMMARY).

The Power On Reset Flag PORF indicates the occurrence of a voltage drop of the internal power supply voltage below  $V_{\text{POR}}$  threshold needed to cause the generation of the device POR. A PORF value of 1 indicates that the voltage had dropped below the threshold level  $V_{\text{POR}}$  and that the time information is corrupted. The value 1 is retained until a 0 is written by the user.

When PORIE bit (EEPROM 35h) is set and the PORF flag was cleared beforehand, an interrupt signal on  $\overline{\text{INT}}$  pin can be generated when a Power On Reset occurs (see POWER ON RESET INTERRUPT FUNCTION).

## 4.2. AUTOMATIC BACKUP SWITCHOVER FUNCTION

### Basic Hardware Definitions:

- The RV-3028-C7 has two power supply pins.
  - $V_{DD}$  is the main power supply input pin.
  - $V_{BACKUP}$  is the backup power supply input pin.
- $V_{TH:LSM}$  (typical value 2.0 V) is the backup switchover threshold voltage in Level Switching Mode.
- A debounce logic provides a debounce time  $t_{DEB}$  of 122  $\mu$ s to 183  $\mu$ s, which will filter  $V_{DD}$  oscillation when the backup switchover will switch back from  $V_{BACKUP}$  to  $V_{DD}$ . I<sup>2</sup>C access is possible in VDD Power state after the debounce time  $t_{DEB}$ .
- The FEDE bit (EEPROM 37h) should always be set to 1, so that Fast Edge Detection ( $\geq 7$  V/ms) is always enabled. – Default value on delivery

### Switchover Modes:

The RV-3028-C7 has three backup switchover modes. The desired mode can be selected by the BSM field in the Configuration EEPROM, see EEPROM BACKUP REGISTER:

- BSM = 00 Switchover disabled (default value on delivery), see SWITCHOVER DISABLED.
- BSM = 01 Direct Switching Mode (DSM): when  $V_{DD} < V_{BACKUP}$ , switchover occurs from  $V_{DD}$  to  $V_{BACKUP}$  without requiring  $V_{DD}$  to drop below  $V_{TH:LSM}$  (2.0 V), see DIRECT SWITCHING MODE (DSM).
- BSM = 10 Switchover disabled, see SWITCHOVER DISABLED.
- BSM = 11 Level Switching Mode (LSM): when  $V_{DD} < V_{TH:LSM}$  (2.0 V) AND  $V_{BACKUP} > V_{TH:LSM}$  (2.0 V), switchover occurs from  $V_{DD}$  to  $V_{BACKUP}$ , see LEVEL SWITCHING MODE (LSM).

### Function Overview:

When a valid backup switchover condition occurs (Direct or Level Switching Mode) and the internal power supply switches to the  $V_{BACKUP}$  voltage (VBACKUP Power state) the following sequence applies:

- The Backup Switch Flag BSF is set and, if BSIE bit is 1 (EEPROM 37h), an interrupt will be generated on  $\overline{INT}$  pin and remains as long as BSF is not cleared to 0. If BSIE is 0 no interrupt will be generated (see AUTOMATIC BACKUP SWITCHOVER INTERRUPT FUNCTION).
- The I<sup>2</sup>C-bus interface is automatically disabled (high impedance) and reset.
- EVI input remains active for interrupt generation, interrupt driven clock output and time stamp function
- CLKOUT pin is held LOW during VBACKUP Power state.
- The interrupt output pin  $\overline{INT}$  remains active in VBACKUP Power state for any previously configured interrupt condition.
- Going into VBACKUP Power state can be used as a time stamp condition (see TIME STAMP FUNCTION).
- The backup switchover condition can also be used to enable the clock output on CLKOUT pin automatically, when again in VDD Power state (see AUTOMATIC BACKUP SWITCHOVER INTERRUPT FUNCTION).

The Backup Switch Flag BSF can be cleared using the I<sup>2</sup>C-bus interface as soon as the circuit resumes from VBACKUP Power state and switched back to  $V_{DD}$ .

Note: After the device has switched back from VBACKUP Power state to VDD Power state the I<sup>2</sup>C interface has to be reinitialized by sending a STOP followed by a START (see also I<sup>2</sup>C-BUS IN SWITCHOVER CONDITION).

### 4.2.1.SWITCHOVER DISABLED

The switchover function is disabled when BSM field (EEPROM 37h) is set to 00 or 10 (BSM = 00 is the default value on delivery).

1. Used when only one power supply is available (device is always in V<sub>DD</sub> Power state). The power supply is applied on V<sub>DD</sub> pin and the V<sub>BACKUP</sub> pin must be tied to V<sub>SS</sub> with a 10 kΩ resistor. The Backup Switch Flag BSF is always logic 0.
2. Used when V<sub>DD</sub> is turned off and V<sub>BACKUP</sub> is still present and the device must not draw any current from the backup source (I<sub>BACKUP</sub> = 0 nA). The backup source on V<sub>BACKUP</sub> pin is in standby mode until the device is powered up again from main supply V<sub>DD</sub> and a switchover mode is selected (see also TYPICAL CHARACTERISTICS).

When the device is first powered up from the backup supply (V<sub>BACKUP</sub>) but without a main supply (V<sub>DD</sub>), switchover is also disabled and the backup source is automatically in standby mode (I<sub>BACKUP</sub> = 0 nA).

### 4.2.2.DIRECT SWITCHING MODE (DSM)

This mode is selected with BSM = 01 (EEPROM 37h).

- If V<sub>DD</sub> > V<sub>BACKUP</sub> the internal power supply is V<sub>DD</sub>.
- If V<sub>DD</sub> < V<sub>BACKUP</sub> the internal power supply is V<sub>BACKUP</sub>.

The Direct Switching Mode is useful in systems where V<sub>DD</sub> is normally higher than V<sub>BACKUP</sub> (for example, V<sub>DD</sub> = 5.0 V, V<sub>BACKUP</sub> = 3.5 V). If the V<sub>DD</sub> and V<sub>BACKUP</sub> values are similar (for example, V<sub>DD</sub> = 3.3 V, V<sub>BACKUP</sub> ≥ 3.0 V), the Direct Switching Mode is not recommended as this can lead to unnecessary switching.

In Direct Switching Mode, the power consumption is reduced compared to the Level Switching Mode (LSM) because V<sub>DD</sub> is not monitored and compared to the threshold voltage V<sub>TH:LSM</sub> = 2.0 V (typical I<sub>DD:DSM</sub> = 95 nA). See also OPERATING PARAMETERS and TYPICAL CHARACTERISTICS.

Note that the circuit needs in worst case 2 ms to react when changing from disabled switchover to DSM.

Backup switchover in Direct Switching Mode and Backup Switchover Interrupt enabled, BSIE = 1 (EEPROM 37h):

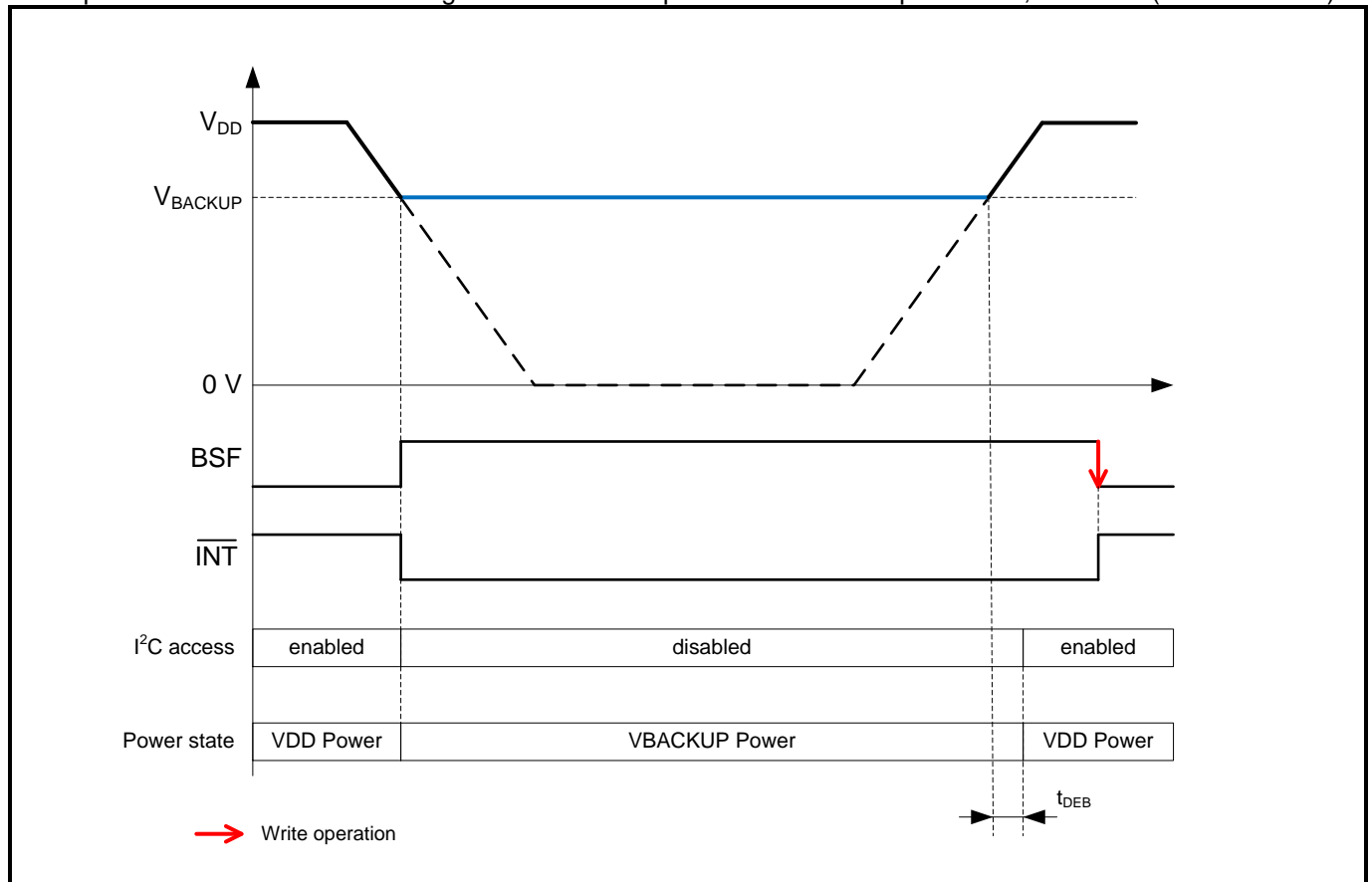

### 4.2.3.LEVEL SWITCHING MODE (LSM)

This mode is selected with BSM = 11 (EEPROM 37h).

- If  $V_{DD} > V_{TH:LSM}$  (2.0 V), the internal power supply is  $V_{DD}$ .
- If  $V_{DD} < V_{TH:LSM}$  (2.0 V) AND  $V_{BACKUP} > V_{TH:LSM}$  (2.0 V), the internal power supply is  $V_{BACKUP}$ .

In Level Switching Mode, the power consumption is slightly increased compared to the Direct Switching Mode (DSM) because  $V_{DD}$  is monitored and compared to the threshold voltage  $V_{TH:LSM} = 2.0$  V (typical  $I_{DD:LSM} = 115$  nA). See also OPERATING PARAMETERS and TYPICAL CHARACTERISTICS.

Note that the circuit needs in worst case 15.625 ms to react when changing from disabled switchover to LSM.

Backup switchover in Level Switching Mode and Backup Switchover Interrupt enabled, BSIE = 1 (EEPROM 37h):

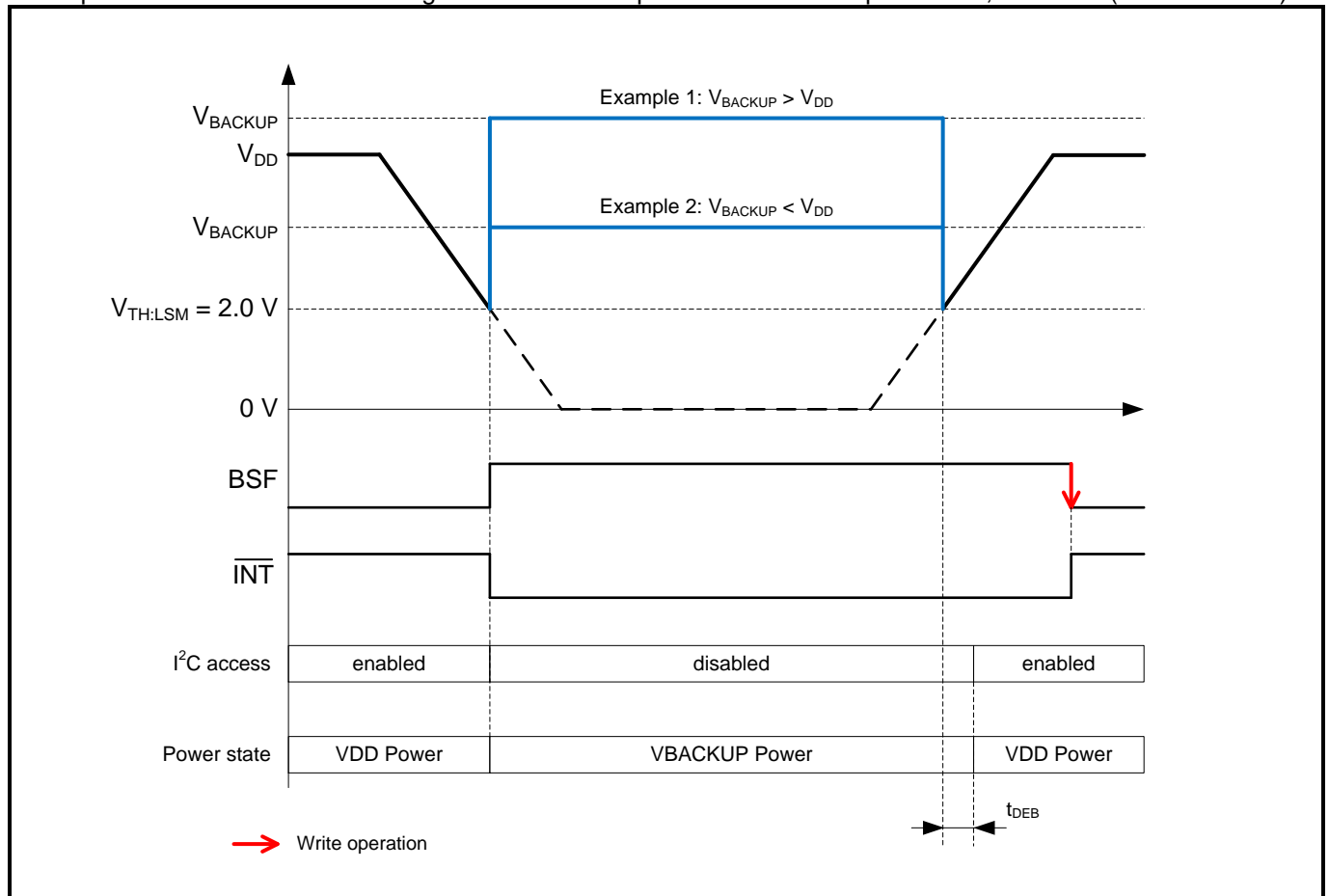

### 4.3. TRICKLE CHARGER

The device supporting the  $V_{\text{BACKUP}}$  pin include a trickle charging circuit which allows a battery or supercapacitor connected to the  $V_{\text{BACKUP}}$  pin to be charged from the power supply connected to the  $V_{\text{DD}}$  pin. See figure below. In the register EEPROM 37h the Trickle Charger is enabled with bit TCE (default value on delivery is disabled) and the series current limiting resistor is selected by the TCR field (default value on delivery is 3 k $\Omega$ ). A schottky diode, with a typical voltage drop of 0.25 V, is inserted in the charging path.

Trickle Charger:

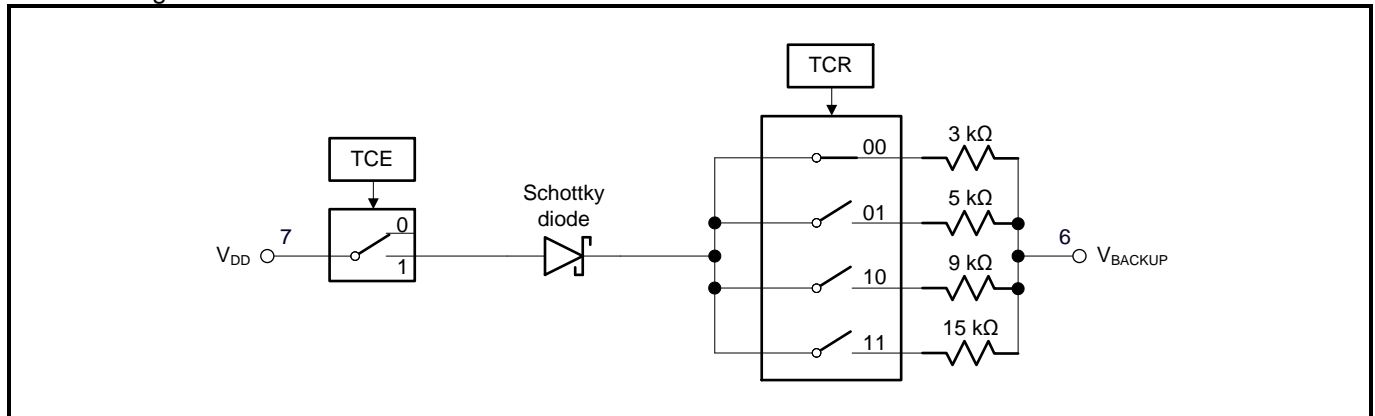

The trickle charger is disabled when the device is in VBACKUP Power state.

### 4.4. PROGRAMMABLE CLOCK OUTPUT

Six different frequencies or the countdown timer interrupt signal can be output on CLKOUT pin, the signal selection is done in the FD field (EEPROM 35h).

- 32.768 kHz, direct from Xtal oscillator, not offset compensated.
- 8192 Hz, 1024 Hz, 64 Hz, 32 Hz, 1 Hz; divided Xtal oscillator frequencies, digitally compensated according to the oscillator offset value EEOffset (EEPROM 36h and 37h).
- Timer interrupt is controlled by the Countdown Timer Control Registers and the Control 1 register.

The negative edge of the original 32,768 kHz clock signal is used to turn on and off a subsequent selected clock signal. The negative edge is also used to control the clock signal with the bits CLKF, CLKOE and the FD field. Whenever the clock signal is LOW, it is pulled to  $V_{\text{SS}}$ .

CLKOUT is tied to  $V_{\text{SS}}$  in VBACKUP Power state independent of the CLKOUT configuration settings.

The frequency output can be controlled directly via the I<sup>2</sup>C-bus interface commands (normal operation) or can be interrupt driven to allow waking up an external system by supplying a clock.

At POR the synchronization function is active since the bit CLKS<sub>Y</sub> is set to 1 (default), the 32.768 kHz frequency is output to CLKOUT pin since the bit CLKOE is set to 1 (default) and FD field is set to 000 (default). Hint: These are the default values on delivery, stored in the Configuration EEPROM with RAM mirror. To customize these POR values, the user can change the values in the Configuration EEPROM.



#### 4.4.1. CLKOUT FREQUENCY SELECTION

A programmable square wave is available at pin CLKOUT. Operation is controlled by the FD field (EEPROM 35h). Frequencies from 32.768 kHz (Default value on delivery) to 1 Hz and countdown timer interrupt can be generated for use as a system clock, microcontroller clock, input to a charge pump, or for calibration of the crystal oscillator.

Pin CLKOUT is a push-pull output that is enabled at power on (Default value on delivery). CLKOUT can be disabled by setting CLKOE bit to 0 or FD field to 111. When disabled, the CLKOUT pin is LOW.

The RESET bit function can affect the CLKOUT signal depending on the selected frequency. When writing 1 to the RESET bit or when writing to the Seconds register and the CLKOUT is enabled, the current period of the frequencies 8192 Hz to 1 Hz are affected (for more details, see RESET BIT FUNCTION).

CLKOUT Frequency Selection:

FD value	CLKOUT Frequency Selection	Effect when writing 1 to the RESET bit or when writing to the Seconds register
000	32.768 kHz –Default value on delivery	No effect
001	8192 Hz <sup>(1)</sup>	Affects current period
010	1024 Hz <sup>(1)</sup>	Affects current period
011	64 Hz <sup>(1)</sup>	Affects current period
100	32 Hz <sup>(1)</sup>	Affects current period
101	1 Hz <sup>(1)</sup>	Affects current period
110	Predefined periodic countdown timer interrupt <sup>(1)</sup> <sup>(2)</sup>	Affects current period
111	CLKOUT = LOW	No effect

<sup>(1)</sup> 8192 Hz to 1 Hz clock pulses and the timer interrupt pulses can be affected by correction pulses (see FREQUENCY OFFSET CORRECTION).  
<sup>(2)</sup> CLKSYS bit has no effect.

#### 4.4.2. NORMAL CLOCK OUTPUT

Setting bit CLKOE to 1 will drive the selected frequency on CLKOUT, setting CLKOE to 0 will clear the selected frequency on CLKOUT.

#### 4.4.3. INTERRUPT CONTROLLED CLOCK OUTPUT

Writing 1 to CLKIE the occurrence of the selected interrupt condition allows frequency output on CLKOUT. This function allows waking up an external system by outputting a clock.

Writing 0 to CLKIE will disable new interrupts from driving frequencies on CLKOUT, but if there is already an active interrupt driven frequency output (CLKF flag is set), the active frequency output will not be stopped. Writing the CLKF flag to 0 will clear the flag and frequency output will stop. Normal (CLKOE) and Interrupt controlled clock output can be activated concurrently (logic OR).

#### 4.4.4.SYNCHRONIZED ENABLE/DISABLE

The enabled Synchronized CLKOUT Enable/Disable function (CLKSY = 1) consists of two sub-functions.

- Synchronized CLKOUT enable ( $t_{CKH}$ ). For enabling clock output on CLKOUT pin the internal first negative clock edge of the selected clock source (FD field) is detected after CLKF or CLKOE are set.
- Synchronized CLKOUT disable ( $t_{CKL}$ ). Clock output on CLKOUT will be disabled at the next negative clock edge of the selected clock source (FD field) after both CLKF and CLKOE are cleared and after the I<sup>2</sup>C-bus interface stop condition. When disabled, CLKOUT is tied to V<sub>SS</sub>.  
(CLKF and CLKOE = 0 → disable condition → next negative clock edge → CLKOUT driven to V<sub>SS</sub>)

Synchronized CLKOUT Enable/Disable times (CLKSY = 1):

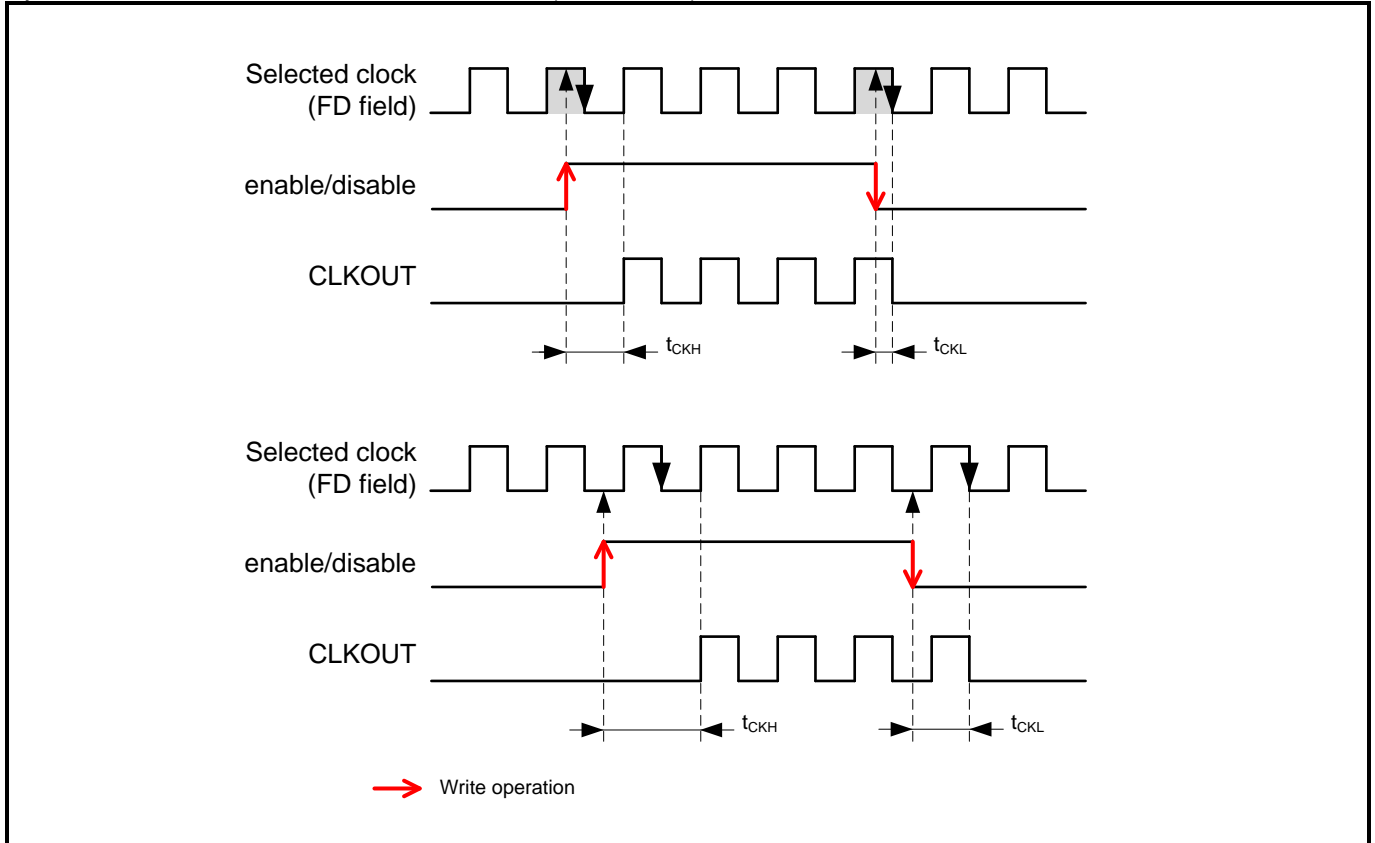

Hint: Glitch free frequency change on CLKOUT requires clearing flag CLKF and bit CLKOE to 0 before the new clock is selected in FD field.

(CLKF and CLKOE = 0 → disable condition → next negative clock edge → CLKOUT driven to V<sub>SS</sub> → FD field selection → CLKF and/or CLKOE = 1 → enable condition → next negative clock edge)

4.4.5.CLOCK OUTPUT SCHEME

Frequency output scheme:

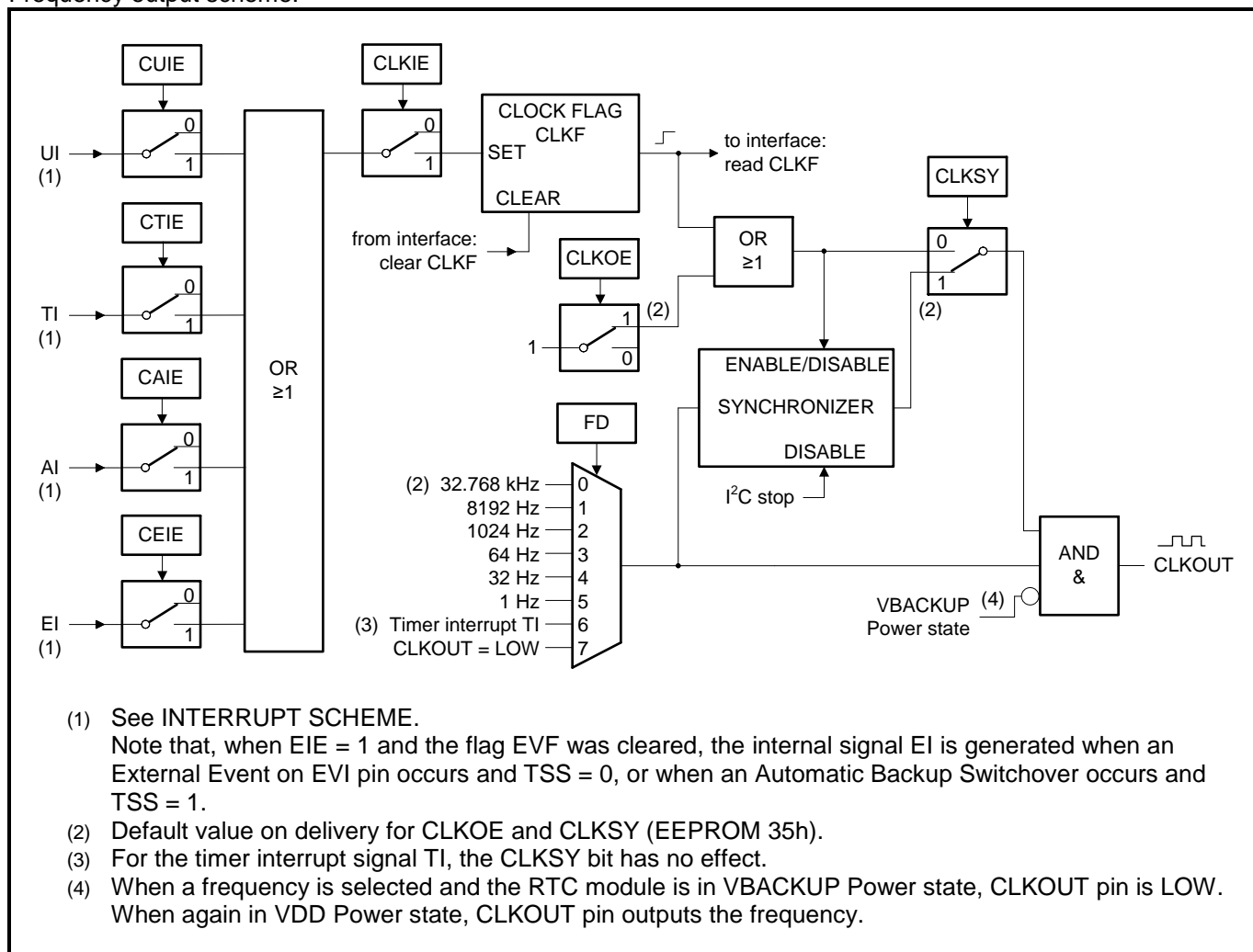

#### 4.5. SETTING AND READING THE TIME

Data flow and data dependencies starting from the 1 Hz clock tick:

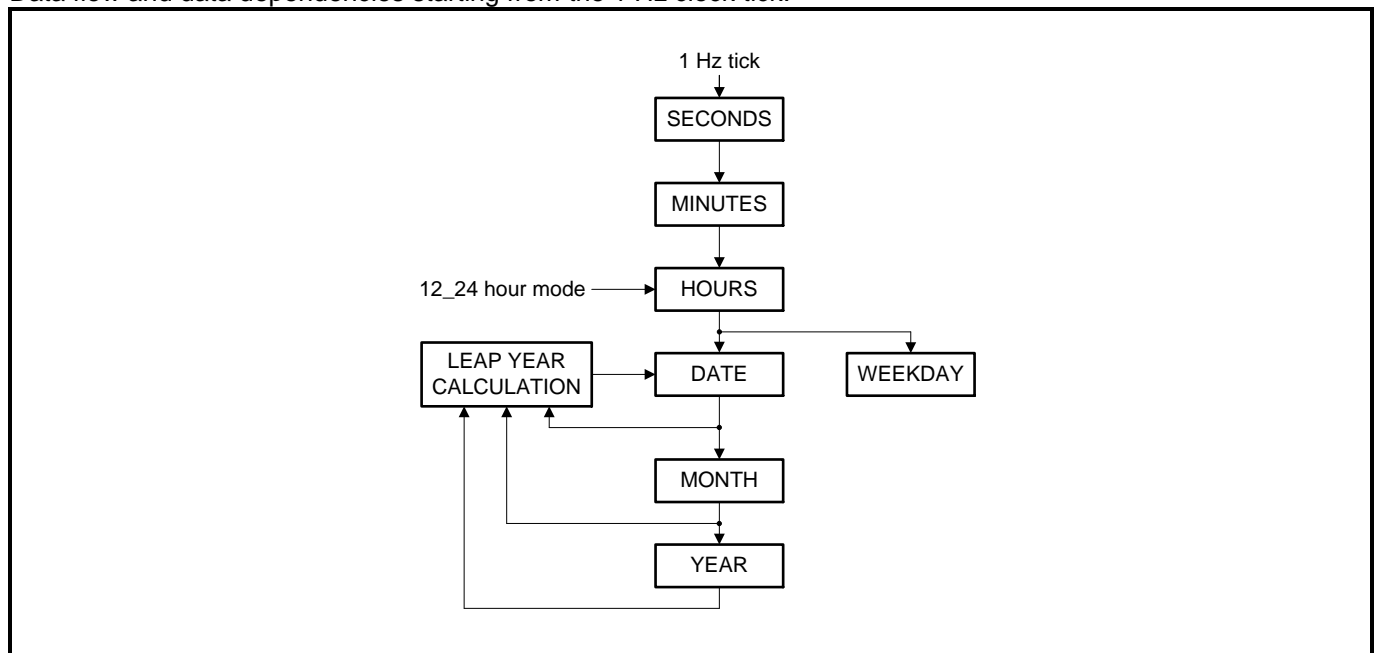

For an I<sup>2</sup>C read/write access that lasts less than 950 milliseconds, all time counters (clock and calendar registers 00h to 06h) of the RV-3028-C7 are blocked. During this time the clock counter increment (1 Hz tick) is inhibited to allow coherent data values. One counter increment (maximum one 1 Hz tick) occurring during inhibition time is memorized and will be realized after the I<sup>2</sup>C STOP condition.

Exception: If during the inhibition time a 1 is written to the RESET bit or a value is written to the Seconds register an eventual present memorized 1 Hz update is reset and the prescaler frequencies from 8192 Hz to 1 Hz are reset. Resetting the prescaler will have an influence on the length of the current clock period on all subsequent peripherals (clock and calendar, CLKOUT, timer clock, update timer clock, UNIX clock, EVI input filter), (see also RESET BIT FUNCTION).

When I<sup>2</sup>C read/write access has been terminated within 950 milliseconds ( $t < 950$  ms), the time counters are unblocked with the I<sup>2</sup>C STOP condition and a pending request to increment the time counters that occurred during read or write access is correctly applied. Maximum one 1 Hz tick can be handled (see following Figure).

Access time for read/write operations:

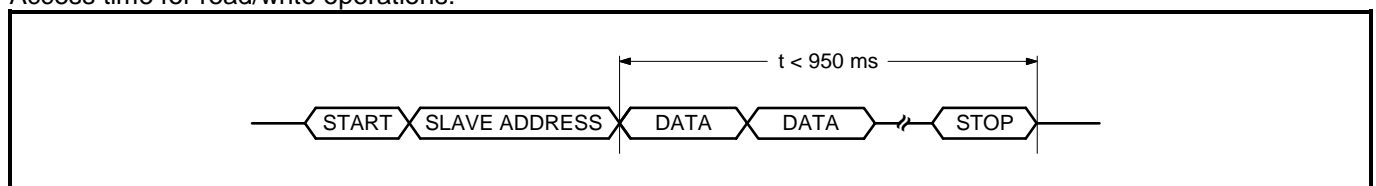

Because of this method, it is very important to make a read or write access in one go, that is, setting or reading seconds through to years should be made in one single access. Failing to comply with this method could result in the time becoming corrupted.

Hint: The UNIX Time counter does not know such register blocking (see UNIX TIME COUNTER).

#### 4.5.1.SETTING THE TIME

During I<sup>2</sup>C write access with an access time smaller than 950 ms the time counters are blocked. After I<sup>2</sup>C STOP condition a possibly memorized 1 Hz tick is realized.

Advantage of register blocking:

- Prevents faulty writing to the clock and calendar registers during an I<sup>2</sup>C write access (no incrementing of time registers during the write access).
- After writing, one memorized 1 Hz tick is handled. Clock and calendar are updated.
- No reading is needed for control. The written data are coherent.

If the I<sup>2</sup>C write access takes longer than 950 ms the I<sup>2</sup>C bus interface is reset by the internal bus timeout function. In this case the previous time counter values are maintained, the pending 1 Hz tick is realized and the clock counter increment (1 Hz tick) continues to operate normally. Restarting of communications begins with transfer of the START condition again.

The I<sup>2</sup>C auto increment Address Pointer is not reset by the I<sup>2</sup>C STOP condition nor by the internal stop forced after timeout.

Two methods for setting the time can be distinguished:

1. Setting the time registers including Seconds register. Writing to the Seconds register resets an eventual present memorized 1 Hz update and resets the prescaler frequencies from 8192 Hz to 1 Hz (synchronization).
2. Setting the time registers without Seconds register. A possibly memorized 1 Hz tick during write access will be realized. Old synchronicity persists.

Hint: Instead of writing to the Seconds register to synchronize the time counters the RESET BIT FUNCTION can be applied. When writing 1 to the RESET bit, the value in the Seconds register does not change, but it also resets the prescaler frequencies from 8192 Hz to 1 Hz (synchronization).

#### 4.5.2.READING THE TIME

During I<sup>2</sup>C read access with an access time smaller than 950 ms the time counters are blocked. After I<sup>2</sup>C STOP condition a possibly memorized 1 Hz tick is realized.

Advantage of register blocking:

- Prevents faulty reading of the clock and calendar registers during an I<sup>2</sup>C read access (no incrementing of time registers during the read access).
- After reading, one memorized 1 Hz tick is handled. Clock and calendar are updated.
- No second reading is needed for control. The read data are coherent.

If the I<sup>2</sup>C read access takes longer than 950 ms the I<sup>2</sup>C bus interface is reset by the internal bus timeout function. In this case all data that is read has a value of FFh, the pending 1 Hz tick is realized and the clock counter increment (1 Hz tick) continues to operate normally. Restarting of communications begins with transfer of the START condition again.

The I<sup>2</sup>C auto increment Address Pointer is not reset by the I<sup>2</sup>C STOP condition nor by the internal stop forced after timeout.

## 4.6. EEPROM READ/WRITE

### 4.6.1.POR REFRESH (ALL CONFIGURATION EEPROM → RAM)

Automatic read of all Configuration EEPROM registers at Power On Reset (POR):

- At power up a refresh of the Configuration RAM mirror values by the values in the Configuration EEPROM is automatically generated (see REGISTER RESET VALUES SUMMARY).
- The time of this first refreshment is  $t_{PREFR} = \sim 66$  ms.
- The EEbusy bit in the register Status (0Eh) can be used to monitor the status of the refreshment.

### 4.6.2.AUTOMATIC REFRESH (ALL CONFIGURATION EEPROM → RAM)

Read all Configuration EEPROM registers automatically:

- To keep the integrity of the configuration data, all data of the Configuration RAM are refreshed by the data in the Configuration EEPROM each 24 hours, at date increment (at the beginning of the last second before midnight).
- The time of this automatic refreshment is  $t_{AREFR} = \sim 3.5$  ms.
- Refresh is only active when RV-3028-C7 is not in VBACKUP mode and not disabled by EERD (EEPROM Memory Refresh Disable) bit.
- Hint: It is not always necessary/meaningful to turn off the auto-refresh (EERD = 1) before an EEPROM access. e.g. if the current RTC time is 1 hour AM, etc.

### 4.6.3.UPDATE (ALL CONFIGURATION RAM → EEPROM)

Write to all Configuration EEPROM registers (see also USE OF THE CONFIGURATION REGISTERS):

- Before starting to change the configuration stored in the EEPROM, the auto refresh of the registers from the EEPROM has to be disabled by writing 1 into the EERD control bit.
- Then the new configuration can be written into the configuration RAM registers, when the whole new configuration is in the registers, writing the command 00h into the register EECMD, then the second command 11h into the register EECMD will start the copy of the configuration into the EEPROM.
- The time of the update is  $t_{UPDATE} = \sim 63$  ms.
- When the transfer is finished (EEbusy = 0), the user can enable again the auto refresh of the registers by writing 0 into the EERD bit in the Control 1 register.

### 4.6.4.REFRESH (ALL CONFIGURATION EEPROM → RAM)

Read all Configuration EEPROM registers:

- Before starting to read the configuration stored in the EEPROM, the auto refresh of the registers from the EEPROM has to be disabled by writing 1 into the EERD control bit.
- Then the actual configuration can be read from the Configuration EEPROM registers, writing the command 00h into the register EECMD, and then the second command 12h into the register EECMD will start the copy of the configuration into the RAM.
- The time of this controlled refreshment is  $t_{REFR} = \sim 3.5$  ms.
- Functions become active as soon as the RAM bytes are written.
- When the transfer is finished (EEbusy = 0), the user can enable again the auto refresh of the registers by writing 0 into the EERD bit in the Control 1 register.

#### 4.6.5. WRITE TO ONE EEPROM BYTE (EEDATA (RAM) → EEPROM)

Write to one EEPROM byte of the Configuration EEPROM or User EEPROM registers:

- Before starting to change data stored in the EEPROM, the auto refresh of the registers from the EEPROM has to be disabled by writing 1 into the EERD control bit.
- In order to write a single byte to the EEPROM, the address to which the data must be written is entered in the EEADDR register and the data to be written is entered in the EEDATA register, then the command 00h is written in the EECMD register, then a second command 21h is written in the EECMD register to start the EEPROM write.
- The time to write to one EEPROM byte is  $t_{\text{WRITE}} = \sim 16$  ms.
- When the transfer is finished (EEbusy = 0), the user can enable again the auto refresh of the registers by writing 0 into the EERD bit in the Control 1 register.

#### 4.6.6. READ ONE EEPROM BYTE (EEPROM → EEDATA (RAM))

Read one EEPROM byte from Configuration EEPROM or User EEPROM registers:

- Before starting to read a byte in the EEPROM, the auto refresh of the registers from the EEPROM has to be disabled by writing 1 into the EERD control bit.
- In order to read a single byte from the EEPROM, the address to be read is entered in the EEADDR register, then the command 00h is written in the EECMD register, then the second command 22h is written in the EECMD register and the resulting byte can be read from the EEDATA register.
- The time to read one EEPROM byte is  $t_{\text{READ}} = \sim 1.4$  ms.
- When the transfer is finished (EEbusy = 0), the user can enable again the auto refresh of the registers by writing 0 into the EERD bit in the Control 1 register.

4.6.7.EEBUSY BIT

The set EEBusy status bit (bit 7 in the Status register 0Eh) indicates that the EEPROM is currently handling a read or write request and will ignore any further commands until the current one is finished. At power up a refresh is automatically generated. The time of this first refreshment is  $t_{PREFR} = \sim 66$  ms. After the refreshment is finished; EEBusy is cleared to 0 automatically. The cleared EEBusy status bit indicates that the EEPROM transfer is finished. To prevent access collision between the internal automatic EEPROM refresh cycle (EERD = 0) and external EEPROM read/write access through interface the following procedures have to be applied.

- Set EERD = 1 Automatic EEPROM Refresh needs to be disabled before EEPROM access.
- Check for EEBusy = 0 Access EEPROM only if not busy.
- Clear EERD = 0 It is recommended to enable Automatic EEPROM Refresh at the end of read/write access.
- Write EEPROM Wait 10 ms after each written EEPROM register before checking for EEBusy = 0 to allow internal data transfer (for Read EEPROM, wait 1 ms).

EEbusy bit flowcharts:

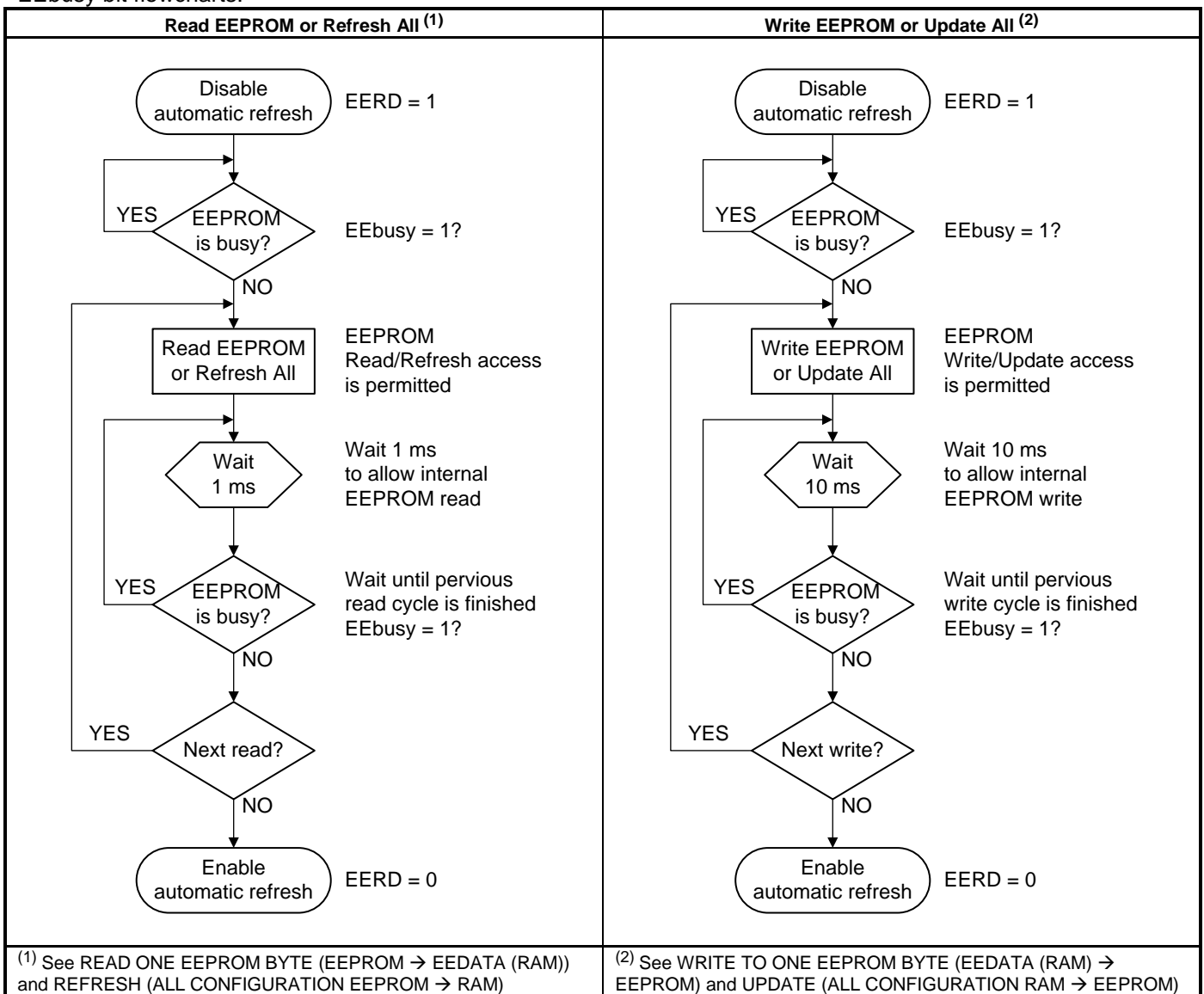

Note: A minimum power supply voltage of  $V_{DD:WRITE} = 1.5$  V during the whole EEPROM write procedure is required; i.e. until EEBusy = 0.



#### 4.6.8. EEPROM READ/WRITE CONDITIONS

During a read/write of the EEPROM, if the  $V_{DD}$  supply drops, the device will continue to operate and communicate until a switchover to  $V_{BAT}$  occurs (in DSM or LSM mode). It is not recommended to operate during this time and all I<sup>2</sup>C communication should be halted as soon as  $V_{DD}$  failure is detected.

During the time that data is being written to the EEPROM,  $V_{DD}$  should remain above the minimum write voltage  $V_{DD:WRITE} = 1.5$  V. If at any time  $V_{DD}$  drops below this voltage, the data written to the device get corrupted.

To write to the EEPROM, the backup switchover circuit must switch back to the main power supply  $V_{DD}$ . See also AUTOMATIC BACKUP SWITCHOVER FUNCTION.

#### 4.6.9. USE OF THE CONFIGURATION REGISTERS

The best practice method to use the Configuration EEPROM with RAM mirror registers at addresses 30h to 37h is to make all Configuration settings in the RAM first and then to update all Configuration EEPROMs by the Update EEPROM command.

Update all Configuration EEPROMs:

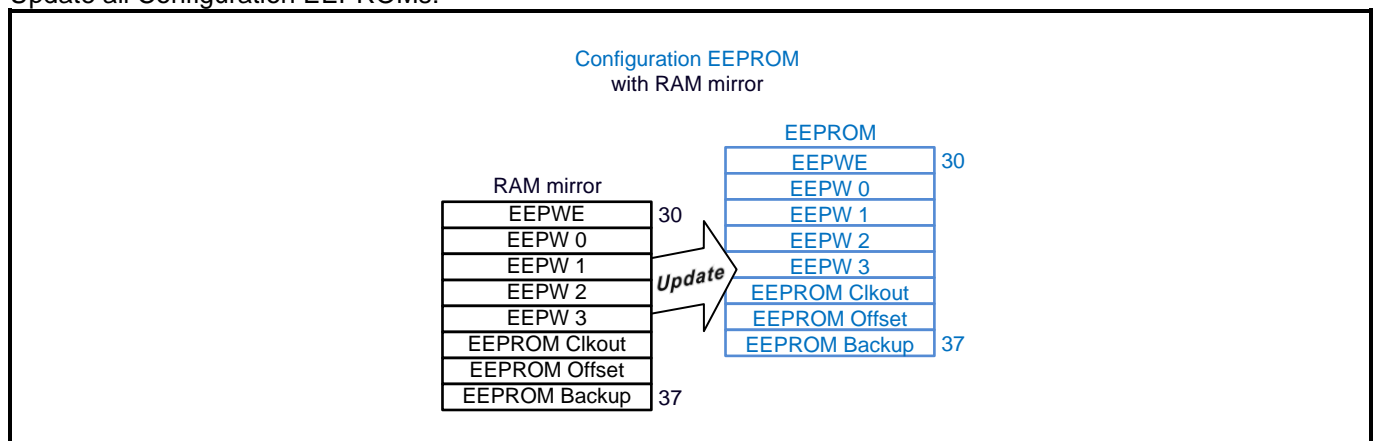

The method, how to enable/disable write protection and how to change the reference password can be found in section USER PROGRAMMABLE PASSWORD (Configuration Registers 30h to 34h).

Configuration Registers 35h to 37h:

- EEPROM CLKOUT REGISTER, 35h – EEPROM Clkout
- EEPROM OFFSET REGISTER, 36h – EEPROM Offset
- EEPROM BACKUP REGISTER, 37h – EEPROM Backup

Edit the Configuration settings (example, when write protection is enabled (EEPWE = 255)):

1. Enter the correct password PW (PW = EEPW) to unlock write protection
2. Disable automatic refresh by setting EERD = 1
3. Edit Configuration settings in registers 35h to 37h (RAM)
4. Update EEPROM (all Configuration RAM → EEPROM) by setting EECMD = 00h followed by 11h
5. Enable automatic refresh by setting EERD = 0
6. Enter an incorrect password PW (PW ≠ EEPW) to lock the device

Note: RAM mirror of the Configuration registers defines the active zone. By writing only to the EEPROM, the configurations are not active. The configurations are activated as soon as a refresh occurs (POR refresh, Automatic refresh or Refresh by software).

Note: To perform certain tests, it is sufficient to use only the RAM mirror. But the new, changed configurations are lost as soon as a refresh occurs (POR refresh, Automatic refresh or Refresh by software).

## 4.7. INTERRUPT OUTPUT

The interrupt pin  $\overline{\text{INT}}$  can be triggered by six different functions:

- PERIODIC COUNTDOWN TIMER INTERRUPT FUNCTION
- PERIODIC TIME UPDATE INTERRUPT FUNCTION
- ALARM INTERRUPT FUNCTION
- EXTERNAL EVENT INTERRUPT FUNCTION
- AUTOMATIC BACKUP SWITCHOVER INTERRUPT FUNCTION
- POWER ON RESET INTERRUPT FUNCTION

### 4.7.1. SERVICING INTERRUPTS

The  $\overline{\text{INT}}$  pin can indicate six types of interrupts. It outputs the logic OR operation result of these interrupt outputs. When an interrupt is detected (when  $\overline{\text{INT}}$  pin produces a negative pulse or is at low level), the TF, UF, AF, EVF, BSF and PORF flags can be read to determine which interrupt event has occurred.

To keep  $\overline{\text{INT}}$  pin from changing to low level, clear the TIE, UIE, AIE, EIE and BSIE (EEPROM 37h) and PORIE (EEPROM 35h) bits. To check whether an event has occurred without outputting any interrupts via the  $\overline{\text{INT}}$  pin, software can read the TF, UF, AF, EVF, BSF and PORF interrupt flags (polling).

Caution: The EVF flag is also set by an event of the Backup Switchover function when bits TSS and TSE are set to 1.

4.7.2. INTERRUPT SCHEME

Interrupt Scheme (Part 1):

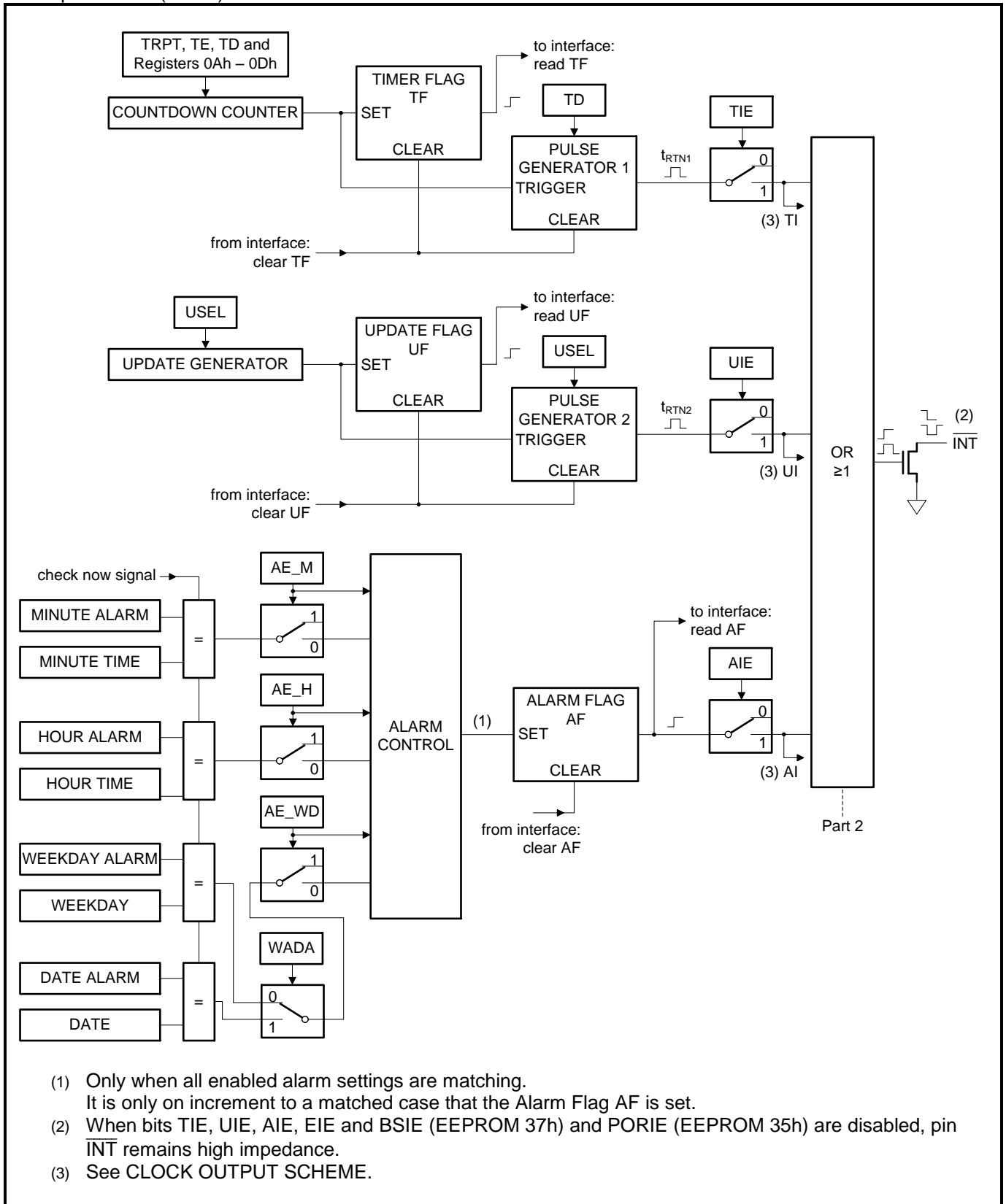

Interrupt Scheme (Part 2):

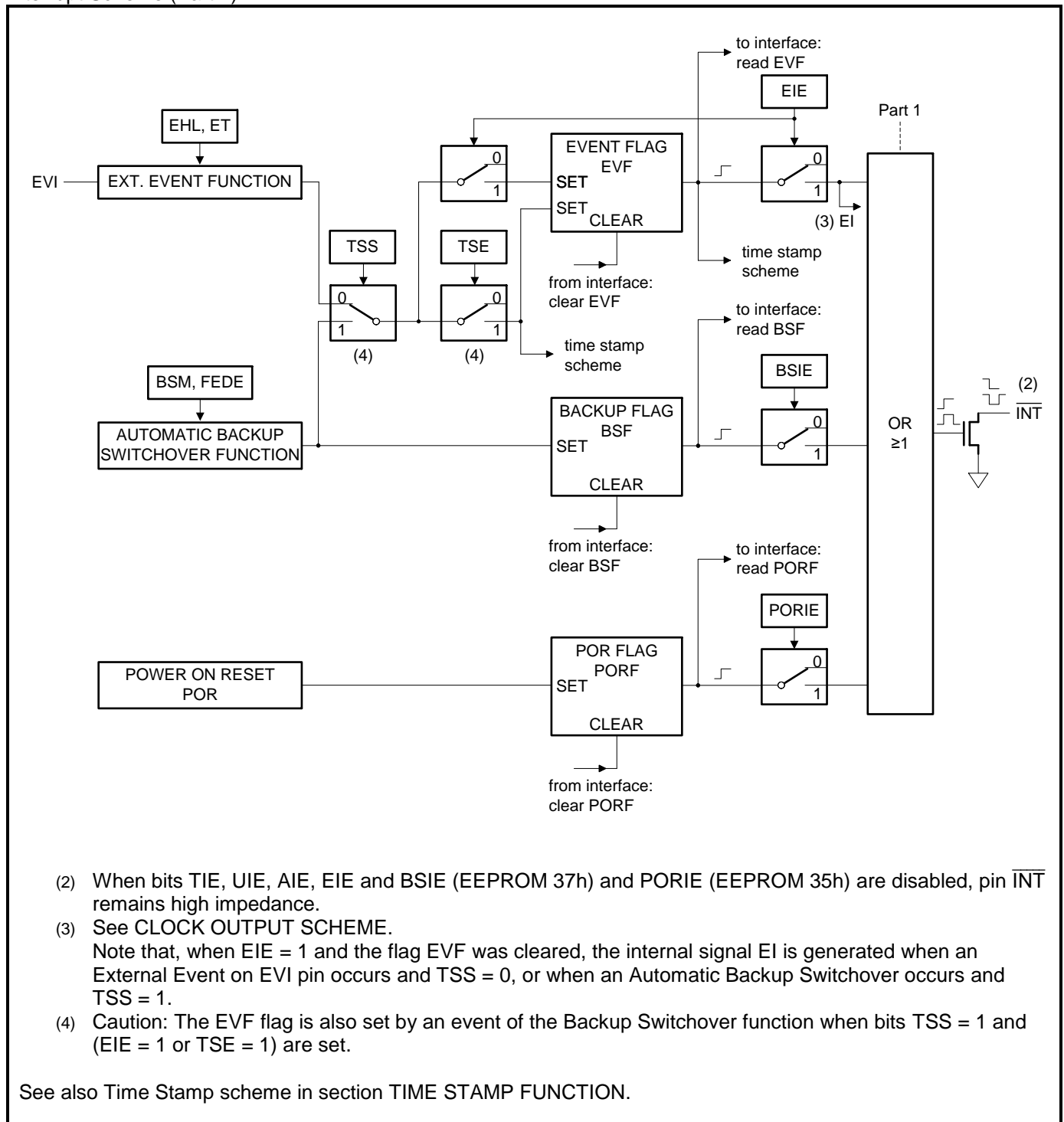

#### 4.8. PERIODIC COUNTDOWN TIMER INTERRUPT FUNCTION

The Periodic Countdown Timer Interrupt function generates an interrupt event once (see SINGLE MODE (TRPT = 0)) or periodically (see REPEAT MODE (TRPT = 1)) at any period set from 244.14  $\mu$ s to 4095 minutes.

When starting the countdown timer for the first time, only the first period does not have a fixed duration. The amount of inaccuracy for the first timer period depends on the selected source clock (see FIRST PERIOD DURATION).

When an interrupt event is generated, the  $\overline{\text{INT}}$  pin goes to the low level and the TF flag is set to 1 to indicate that an event has occurred. The output on the  $\overline{\text{INT}}$  pin is only effective if the TIE bit in the Control 2 register is set to 1. The low-level output signal on  $\overline{\text{INT}}$  pin (and on CLKOUT pin, when driven by TI signal) is automatically cleared after the Auto reset time  $t_{\text{RTN1}}$  or it is cancelled when TF flag is cleared to 0.

- When TD = 00,  $t_{\text{RTN1}} = 122 \mu\text{s}$
- When TD = 01, 10 or 11,  $t_{\text{RTN1}} = 7.813 \text{ ms}$

When bit TIE is set to 1, the internal countdown timer interrupt pulse (TI) can be used to enable the clock output on CLKOUT pin automatically, when bits CTIE, CLKIE and CLKOE are set to 1 and a frequency is selected in the FD field. The interrupt pulses (TI) can even be used as CLKOUT frequency, when selecting 110 in the FD field (see CLOCK OUTPUT SCHEME).

4.8.1.PERIODIC COUNTDOWN TIMER DIAGRAM

Diagram of the Periodic Countdown Timer Interrupt function: Example with Repeat Mode (TRPT = 1), Interrupt on  $\overline{\text{INT}}$  pin (TIE = 1) and Countdown Timer Signal on CLKOUT pin (CLKOE = 1, FD = 110).

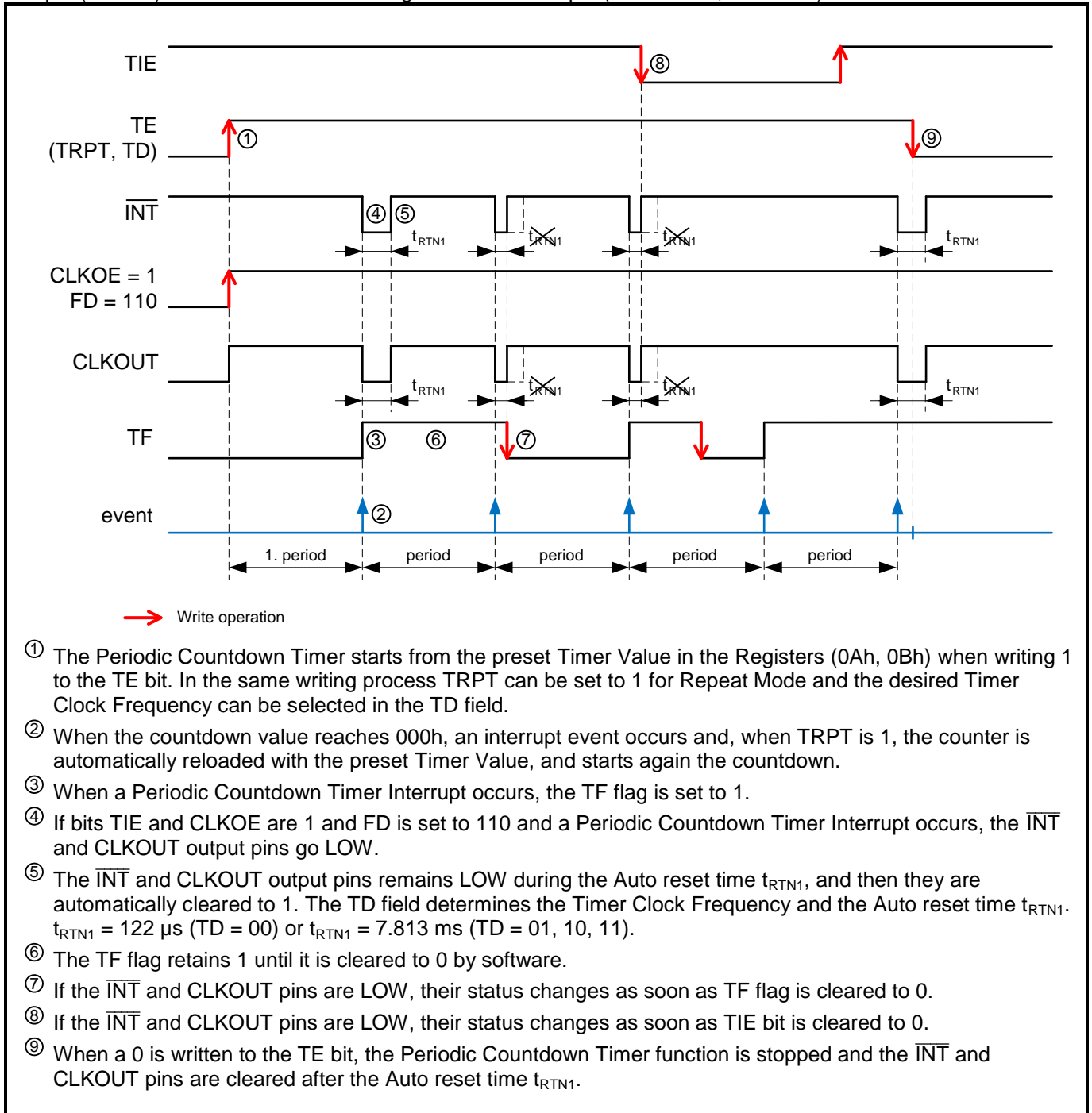

#### 4.8.2.USE OF THE PERIODIC COUNTDOWN TIMER INTERRUPT

The following registers, fields and bits are related to the Periodic Countdown Timer Interrupt and Automatic Clock output function:

- Timer Value 0 Register (0Ah) (see PERIODIC COUNTDOWN TIMER CONTROL REGISTERS)
- Timer Value 1 Register (0Bh) (see PERIODIC COUNTDOWN TIMER CONTROL REGISTERS)
- Timer Status 0 Register (0Ch) (see PERIODIC COUNTDOWN TIMER CONTROL REGISTERS)
- Timer Status 1 shadow Register (0Dh) (see PERIODIC COUNTDOWN TIMER CONTROL REGISTERS)
- TF flag (see STATUS AND CONTROL REGISTERS, 0Eh – Status)
- TRPT bit, TE bit and TD field (see STATUS AND CONTROL REGISTERS, 0Fh – Control 1)
- TIE bit (see STATUS AND CONTROL REGISTERS, 10h – Control 2)
- CTIE bit (see STATUS AND CONTROL REGISTERS, 12h – Clock Interrupt Mask)

For selecting Countdown Timer Signal for CLKOUT pin (CLKOE = 1 and FD = 110):

- CLKOE bit and FD field (see EEPROM CLKOUT REGISTER, 35h – EEPROM Clkout)

Prior to entering any timer settings for the Periodic Countdown Timer Interrupt, it is recommended to write a 0 to the TIE and TE bits to prevent inadvertent interrupts on  $\overline{\text{INT}}$  pin. When writing 1 to the RESET bit or writing a value to the Seconds register affects the length of a current countdown period (see RESET BIT FUNCTION). When the Periodic Countdown Timer Interrupt function is not used, one Timer Value register (0Ah) can be used as RAM byte. The Timer Clock Frequency selection field TD is used to set the countdown period (source clock) for the Periodic Countdown Timer Interrupt function (four settings are possible).

Procedure to start the Periodic Countdown Timer Interrupt function and the Automatic Clock output function:

1. Initialize bits TE, TIE and TF to 0. In that order, to prevent inadvertent interrupts on  $\overline{\text{INT}}$  pin.
2. Set TRPT bit to 1 if periodic countdown is needed (Repeat Mode).
3. Choose the Timer Clock Frequency and write the corresponding value in the TD field.
4. Choose the Countdown Period based on the Timer Clock Frequency, and write the corresponding Timer Value to the registers Timer Value 0 (0Ah) and Timer Value 1 (0Bh). See following table.
5. Set the TIE bit to 1 if you want to get a hardware interrupt on  $\overline{\text{INT}}$  pin.
6. Set CTIE bit to 1 to enable clock output when a timer interrupt occurs. See also CLOCK OUTPUT SCHEME.
7. Set the TIE and CLKOE bits to 1 and the FD field to 110 if you want to get the timer signal on CLKOUT.
8. Set the TE bit from 0 to 1 to start the Periodic Countdown Timer. The countdown starts at the rising edge of the SCL signal after Bit 0 of the Address 0Fh is transferred. See subsequent Figure that shows the start timing.

Countdown Period in seconds:

$$\text{Countdown Period} = \frac{\text{Timer Value}}{\text{Timer Clock Frequency}}$$

Countdown Period:

Timer Value (0Ah and 0Bh)	Countdown Period			
	TD = 00 (4096 Hz)	TD = 01 (64 Hz)	TD = 10 (1 Hz)	TD = 11 (1/60 Hz)
0	-	-	-	-
1	244.14 $\mu$ s	15.625 ms	1 s	1 min
2	488.28 $\mu$ s	31.25 ms	2 s	2 min
:	:	:	:	:
41	10.010 ms	640.63 ms	41 s	41 min
205	50.049 ms	3.203 s	205 s	205 min
410	100.10 ms	6.406 s	410 s	410 min
2048	500.00 ms	32.000 s	2048 s	2048 min
:	:	:	:	:
4095 (FFFh)	0.9998 s	63.984 s	4095 s	4095 min

General countdown timer behavior:

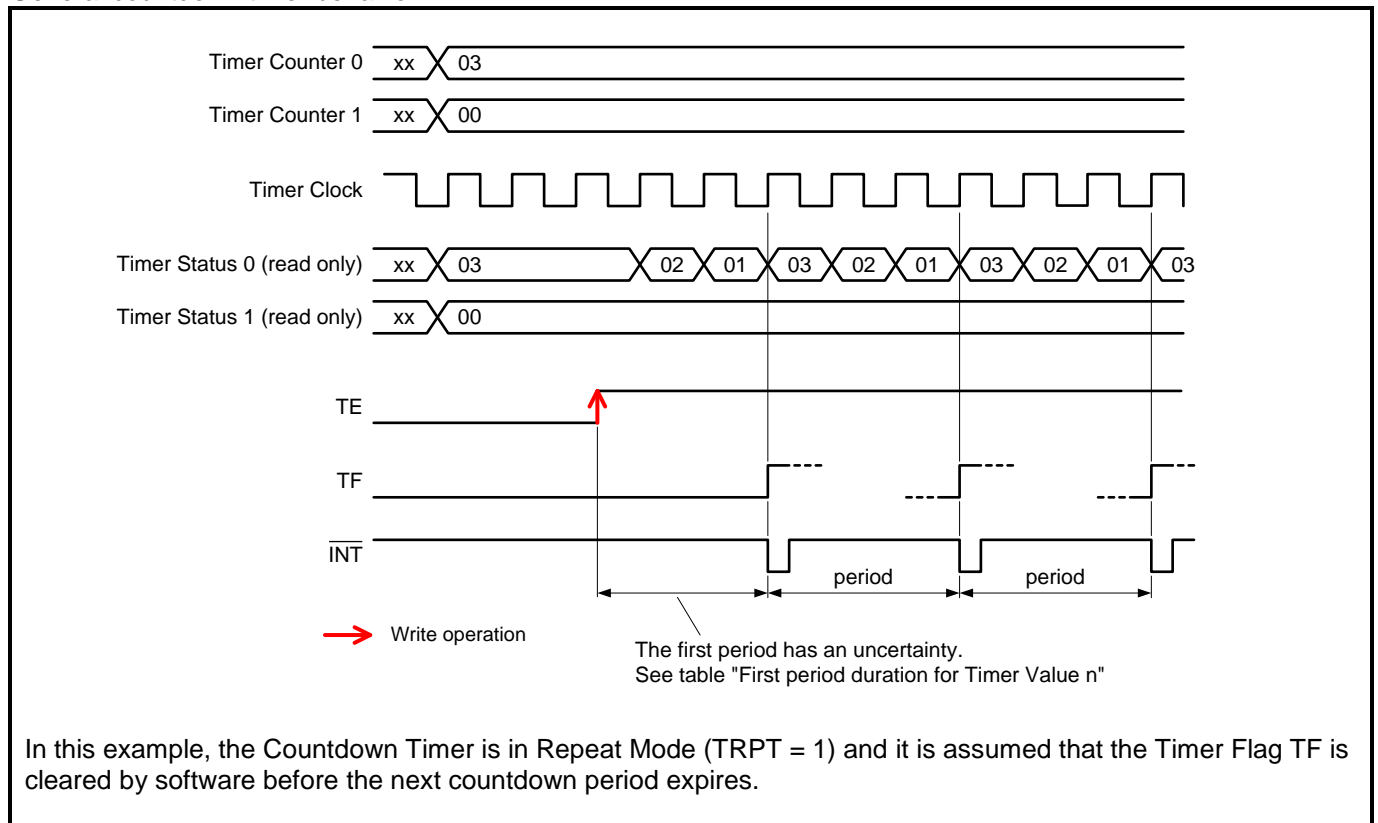

Start timing of the Periodic Countdown Timer:

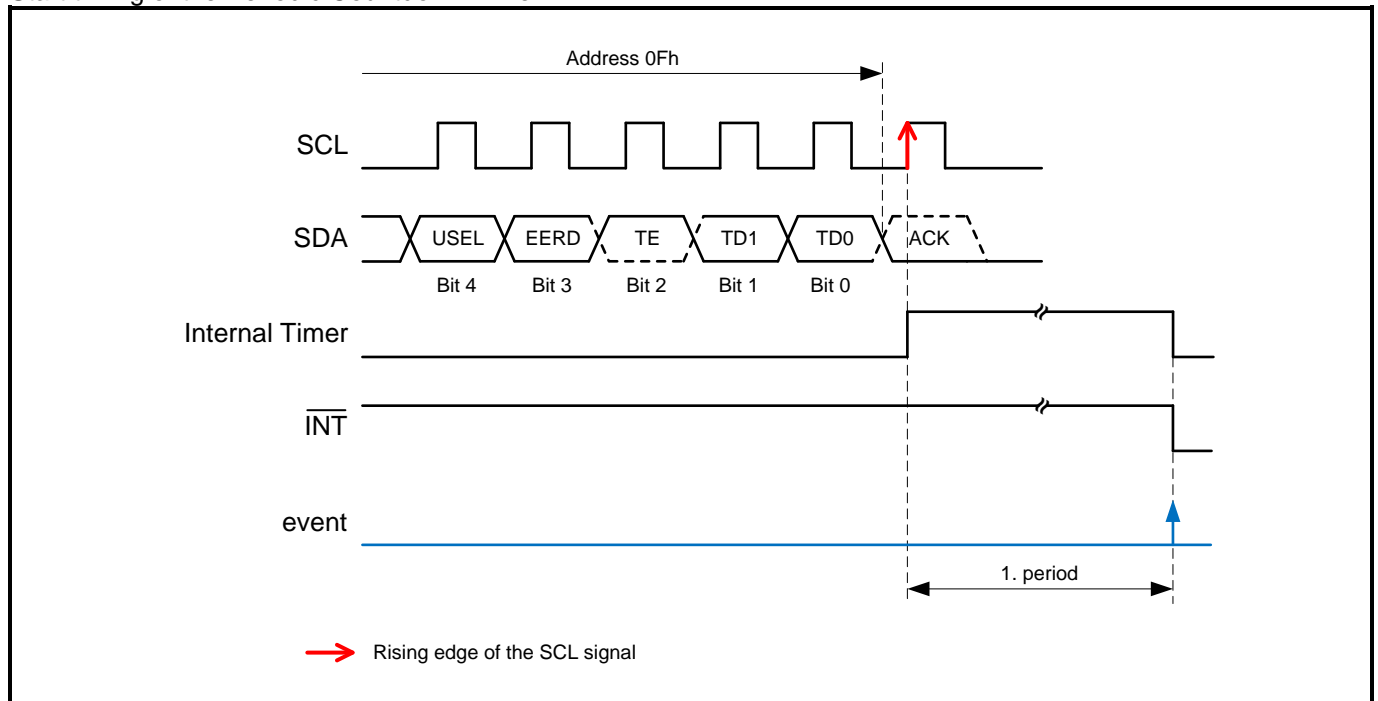



### 4.8.3.FIRST PERIOD DURATION

When the TF flag is set, it indicates that an interrupt signal on  $\overline{\text{INT}}$  is generated if this mode is enabled. See Section INTERRUPT OUTPUT for details on how the interrupt can be controlled.

When starting the timer for the first time, the first period has an uncertainty. The uncertainty arises because of the activation instruction of the interface clock, which is not synchronous to the Timer Clock Frequency. Subsequent timer periods do not have such deviation. The amount of deviation for the first timer period depends on the chosen Timer Clock Frequency, see following Table.

First period duration for Timer Value  $n^{(1)}$ :

TD value	Timer Clock Frequency	First period duration		Subsequent periods duration
		Minimum Period	Maximum Period	
00	4096 Hz	$n \times 244 \mu\text{s}$	$(n + 1) \times 244 \mu\text{s}$	$n \times 244 \mu\text{s}$
01	64 Hz	$n \times 15.625 \text{ ms}$	$(n + 1) \times 15.625 \text{ ms}$	$n \times 15.625 \text{ ms}$
10	1 Hz	$n \times 1 \text{ s}$	$n \times 1 \text{ s} + 15.625 \text{ ms}$	$n \times 1 \text{ s}$
11	1/60 Hz	$n \times 60 \text{ s}$	$n \times 60 \text{ s} + 15.625 \text{ ms}$	$n \times 60 \text{ s}$

<sup>(1)</sup> Timer Values  $n$  from 1 to 4095 are valid. When the Timer Value is set to 0, the countdown timer does not start.

At the end of every countdown, the timer sets the Periodic Countdown Timer Flag (bit TF in Status Register). The TF flag can only be cleared by command. When enabled, a pulse is generated at the interrupt pin  $\overline{\text{INT}}$ .

When reading the Timer Value (Timer Value 0 and Timer Value 1), the preset value is returned and not the actual value. The actual value of the Periodic Countdown Timer can be read in the registers Timer Status 0 and Timer Status 1.

### 4.8.4.SINGLE MODE (TRPT = 0)

If TRPT bit is set to 0 (default), Single Mode is selected. In Single Mode the countdown timer will stop after reaching 0 and bit TE will be cleared automatically. The TF flag retains 1 until it is cleared to 0 by software.

Hint: An ongoing countdown can be stopped by writing 0 to the TE bit. No interrupt will be executed. The Timer Status 0 and Timer Status 1 registers store the last updated value.

### 4.8.5.REPEAT MODE (TRPT = 1)

If TRPT bit is set to 1, Repeat Mode is selected. In Repeat Mode the countdown timer is in the periodic countdown mode where it will be automatically reloaded with the Timer Value from the Timer Value 0 and Timer Value 1 registers when reaching 0. This will repeat until TE is cleared to 0. When a 0 is written to the TE bit, the Timer Status 0 and Timer Status 1 registers store the last updated value. The TF flag retains 1 until it is cleared to 0 by software.

Caution: Changing only TRPT from 1 to 0 during countdown to stop the function will automatically reload the countdown timer with the preset Timer Value immediately because TE in the same register is still 1. The last countdown period will therefore be longer as intended but will stop correctly after reaching 0 and bit TE will be cleared automatically.

Caution: A running countdown should not be stopped by writing 0 to the Timer Value because RV-3028-C7 outputs 64 Hz when the countdown value reaches 0. Write as usual 0 to the TE bit to stop the function.

### 4.9. PERIODIC TIME UPDATE INTERRUPT FUNCTION

The Periodic Time Update Interrupt function generates an interrupt event periodically at the One-Second or the One-Minute update time, according to the selected timer source with bit USEL.

When an interrupt event is generated, the  $\overline{\text{INT}}$  pin goes to the low level and the UF flag is set to 1 to indicate that an event has occurred. The output on  $\overline{\text{INT}}$  pin is only effective if UIE bit in Control 2 register is set to 1. The low-level output signal on the  $\overline{\text{INT}}$  pin is automatically cleared after the Auto reset time  $t_{\text{RTN2}}$  or it is cancelled when UF flag is cleared to 0.

- When USEL = 0 (Second update),  $t_{\text{RTN2}} = 500 \text{ ms}$
- When USEL = 1 (Minute update),  $t_{\text{RTN2}} = 7.813 \text{ ms}$

When bit UIE is set to 1, the internal update interrupt pulse (UI) can be used to enable the clock output on CLKOUT pin automatically, when bits CUIE, CLKIE and CLKOE are set to 1 and a frequency is selected in the FD field (see CLOCK OUTPUT SCHEME).

#### 4.9.1. PERIODIC TIME UPDATE DIAGRAM

Diagram of the Periodic Time Update Interrupt function:

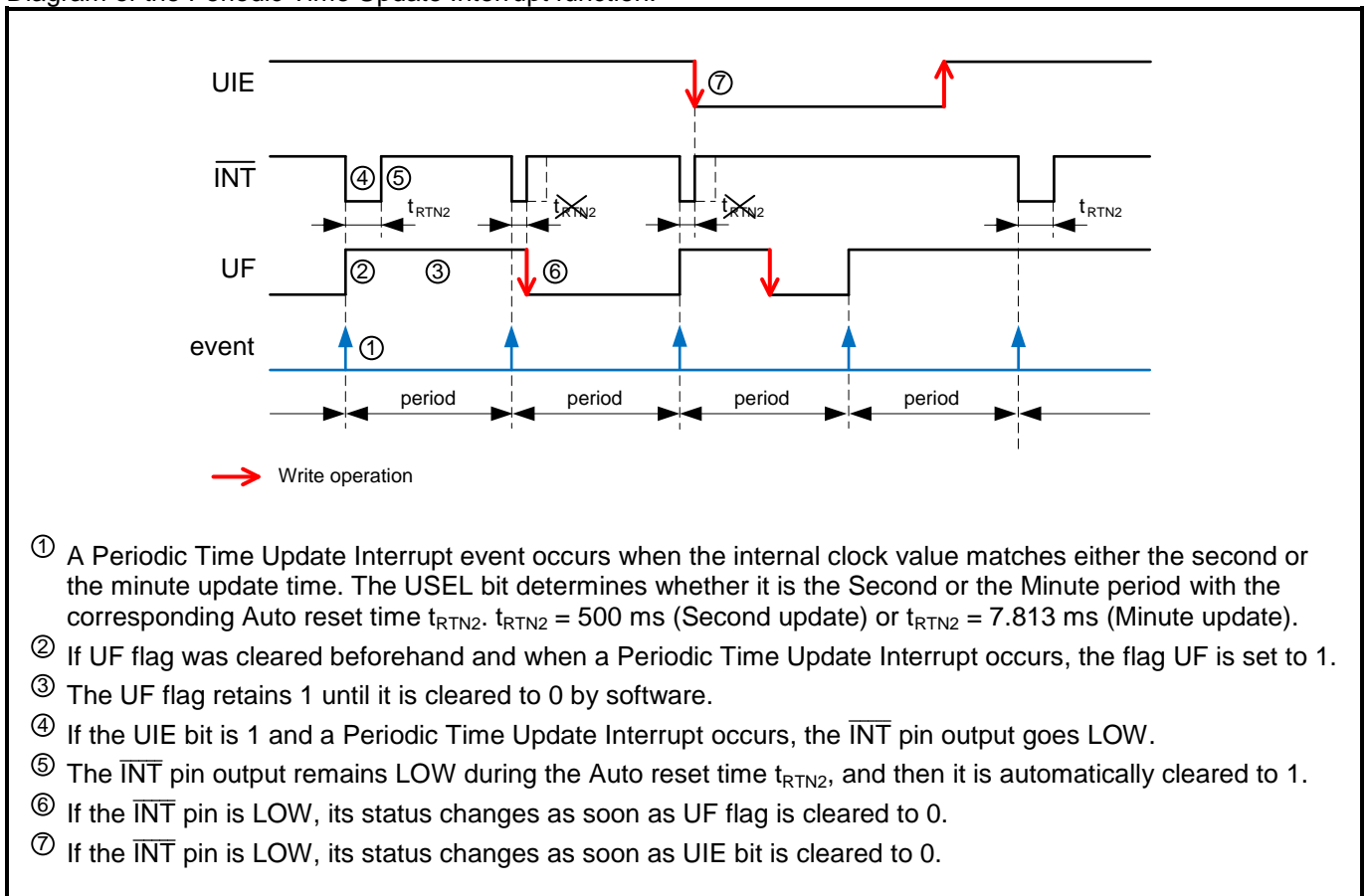

#### 4.9.2.USE OF THE PERIODIC TIME UPDATE INTERRUPT

The following bits are related to the Periodic Time Update Interrupt and Automatic Clock output function:

- UF flag (see STATUS AND CONTROL REGISTER, 0Eh – Status)
- USEL bit (see STATUS AND CONTROL REGISTER, 0Fh – Control 1)
- UIE bit (see STATUS AND CONTROL REGISTER, 10h – Control 2)
- CUIE bit (see STATUS AND CONTROL REGISTERS, 12h – Clock Interrupt Mask)

Prior to entering any other settings, it is recommended to write a 0 to the UIE bit to prevent inadvertent interrupts on  $\overline{\text{INT}}$  pin. The Periodic Time Update Interrupt function cannot be fully stopped, but by writing a 0 in the UIE bit, it prevents the occurrence of a hardware interrupt on the  $\overline{\text{INT}}$  pin.

When writing 1 to the RESET bit or when writing to the Seconds register affects the length of a current update period (see RESET BIT FUNCTION).

Procedure to use the Periodic Time Update Interrupt and Automatic Clock output function:

1. Initialize bits UIE and UF to 0.
2. Choose the timer source clock and write the corresponding value in the USEL bit.
3. Set the UIE bit to 1 if you want to get a hardware interrupt on  $\overline{\text{INT}}$  pin.
4. Set CUIE bit to 1 to enable clock output when a time update interrupt occurs. See also CLOCK OUTPUT SCHEME.
5. The first interrupt will occur after the next event, either second or minute change.

## 4.10. ALARM INTERRUPT FUNCTION

The Alarm Interrupt function generates an interrupt for alarm settings such as weekday/date, hour and minute settings.

When an interrupt event is generated, the  $\overline{\text{INT}}$  pin goes to the low level and the AF flag is set to 1 to indicate that an event has occurred. The output on the  $\overline{\text{INT}}$  pin is only effective if the AIE bit in the Control 2 register is set to 1.

When bit AIE is set to 1, the internal alarm interrupt signal (AI) can be used to enable the clock output on CLKOUT pin automatically, when bits CAIE, CLKIE and CLKOE are set to 1 and a frequency is selected in the FD field (see CLOCK OUTPUT SCHEME).

### 4.10.1. ALARM DIAGRAM

Diagram of the Alarm Interrupt function:

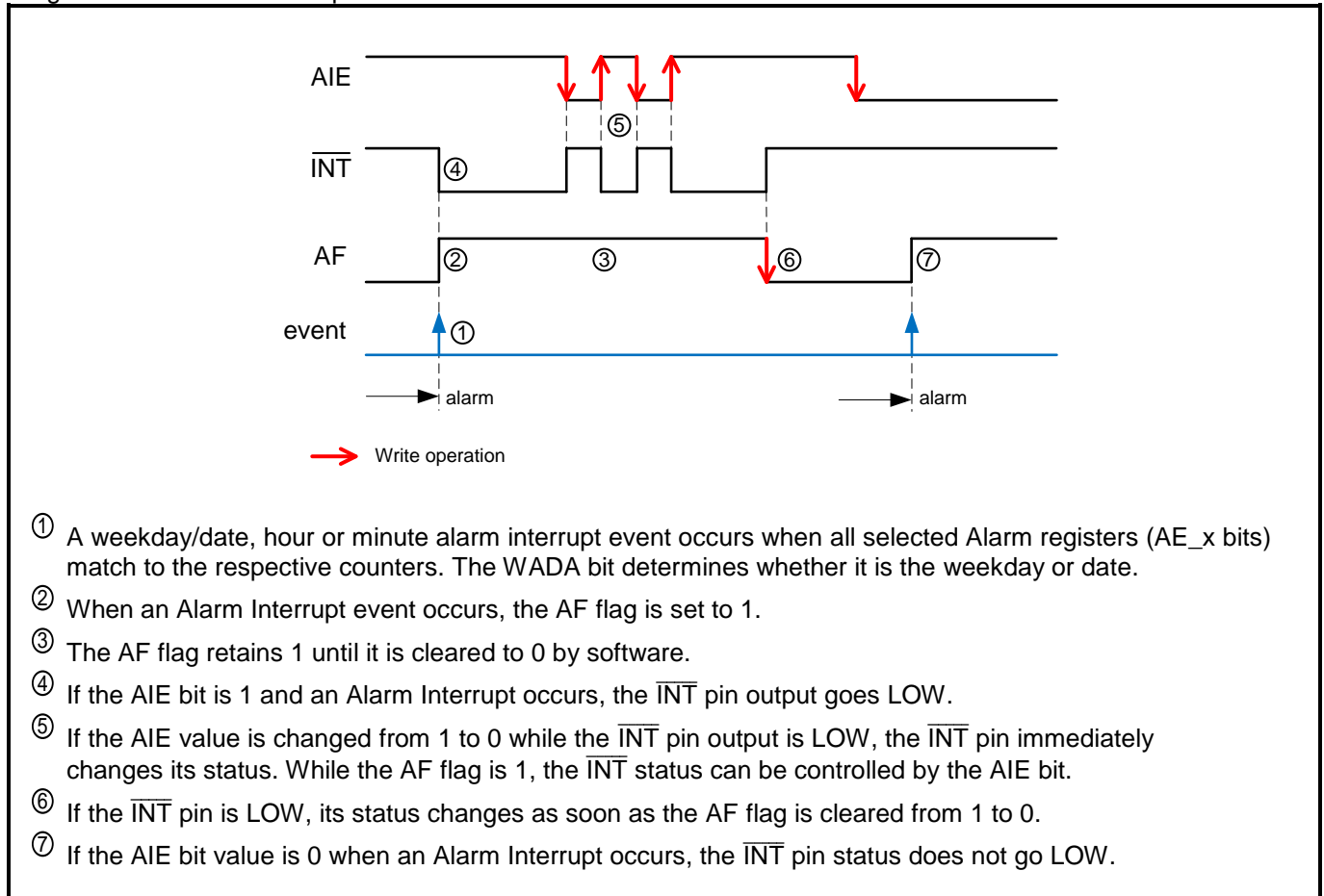

#### 4.10.2. USE OF THE ALARM INTERRUPT

The following registers and bits are related to the Alarm Interrupt and Automatic Clock output function:

- Minutes Register (01h) (see CLOCK REGISTERS)
- Hours Register (02h) (see CLOCK REGISTERS)
- Weekday Register (03h) (see CALENDAR REGISTERS)
- Date Register (04h) (see CALENDAR REGISTERS)
- Minutes Alarm Register and AE\_M bit (07h) (see ALARM REGISTERS)
- Hours Alarm Register and AE\_H bit (08h) (see ALARM REGISTERS)
- Weekday/Date Alarm Register and AE\_WD bit (09h) (see ALARM REGISTERS)
- AF flag (see STATUS AND CONTROL REGISTER, 0Eh – Status)
- WADA bit (see STATUS AND CONTROL REGISTERS, 0Fh – Control 1)
- AIE and 12\_24 bits (see STATUS AND CONTROL REGISTERS, 10h – Control 2)
- CAIE bit (see STATUS AND CONTROL REGISTERS, 12h – Clock Interrupt Mask)

Prior to entering any timer settings for the Alarm Interrupt, it is recommended to write a 0 to the AIE bit to prevent inadvertent interrupts on  $\overline{\text{INT}}$  pin. When writing 1 to the RESET bit or writing a value to the Seconds register affects the time to the next alarm interrupt (see RESET BIT FUNCTION). When the Alarm Interrupt function is not used, one Byte (07h) of the Alarm registers can be used as RAM byte. In such case, be sure to write a 0 to the AIE bit (if the AIE bit value is 1 and the Alarm register is used as RAM register,  $\overline{\text{INT}}$  may change to low level unintentionally).

Procedure to use the Alarm Interrupt and Automatic Clock output function:

1. Initialize bits AIE and AF to 0.
2. Choose weekday alarm or date alarm (weekday/date) by setting the WADA bit. WADA = 0 for weekday alarm or WADA = 1 for date alarm.
3. Write the desired alarm settings in registers 07h to 09h. The three alarm enable bits, AE\_M, AE\_H and AE\_WD, are used to select the corresponding register that has to be taken into account for match or not. See the following table.
4. Set CAIE bit to 1 to enable clock output when an alarm occurs. See also CLOCK OUTPUT SCHEME.
5. Set the AIE bit to 1 if you want to get a hardware interrupt on  $\overline{\text{INT}}$  pin.

Alarm Interrupt:

Alarm enable bits			Alarm event
AE_WD	AE_H	AE_M	
0	0	0	When minutes, hours and weekday/date match (once per weekday/date)
0	0	1	When hours and weekday/date match (once per weekday/date)
0	1	0	When minutes and weekday/date match (once per hour per weekday/date)
0	1	1	When weekday/date match (once per weekday/date)
1	0	0	When hours and minutes match (once per day)
1	0	1	When hours match (once per day)
1	1	0	When minutes match (once per hour)
1	1	1	All disabled – Default value

AE\_x bits (where x is WD, H or M)  
 AE\_x = 0: Alarm is enabled  
 AE\_x = 1: Alarm is disabled – Default value

#### 4.11. EXTERNAL EVENT INTERRUPT FUNCTION

The External Event Interrupt and the Time Stamp function are enabled by the control bits TSS, TSE and EIE. With the ET field the EVI input events can be configured either for edge detection, or for level detection with filtering, and with the EHL bit the active edge or level can be configured.

If enabled (TSS = 0, TSE = 1, EIE = 1 and EVF flag was cleared to 0 before) and an External Event on EVI pin is detected, the clock and calendar registers are captured and copied into the Time Stamp registers, the  $\overline{INT}$  is issued and the EVF flag is set to 1 to indicate that an external event has occurred.

If enabled (TSS = 0 and EIE, CEIE, CLKIE and CLKOE are set to 1 and a frequency is selected in the FD field), the internal event interrupt signal (EI) can be used to enable the clock output on CLKOUT pin automatically (see CLOCK OUTPUT SCHEME).

Caution: The EVF flag is also set by an event of the Backup Switchover function when bits TSS and TSE are set to 1.

4.11.1. EXTERNAL EVENT DIAGRAM

Diagram of the External Event Interrupt function. Example with EHL = 1 for high level / rising edge detection:

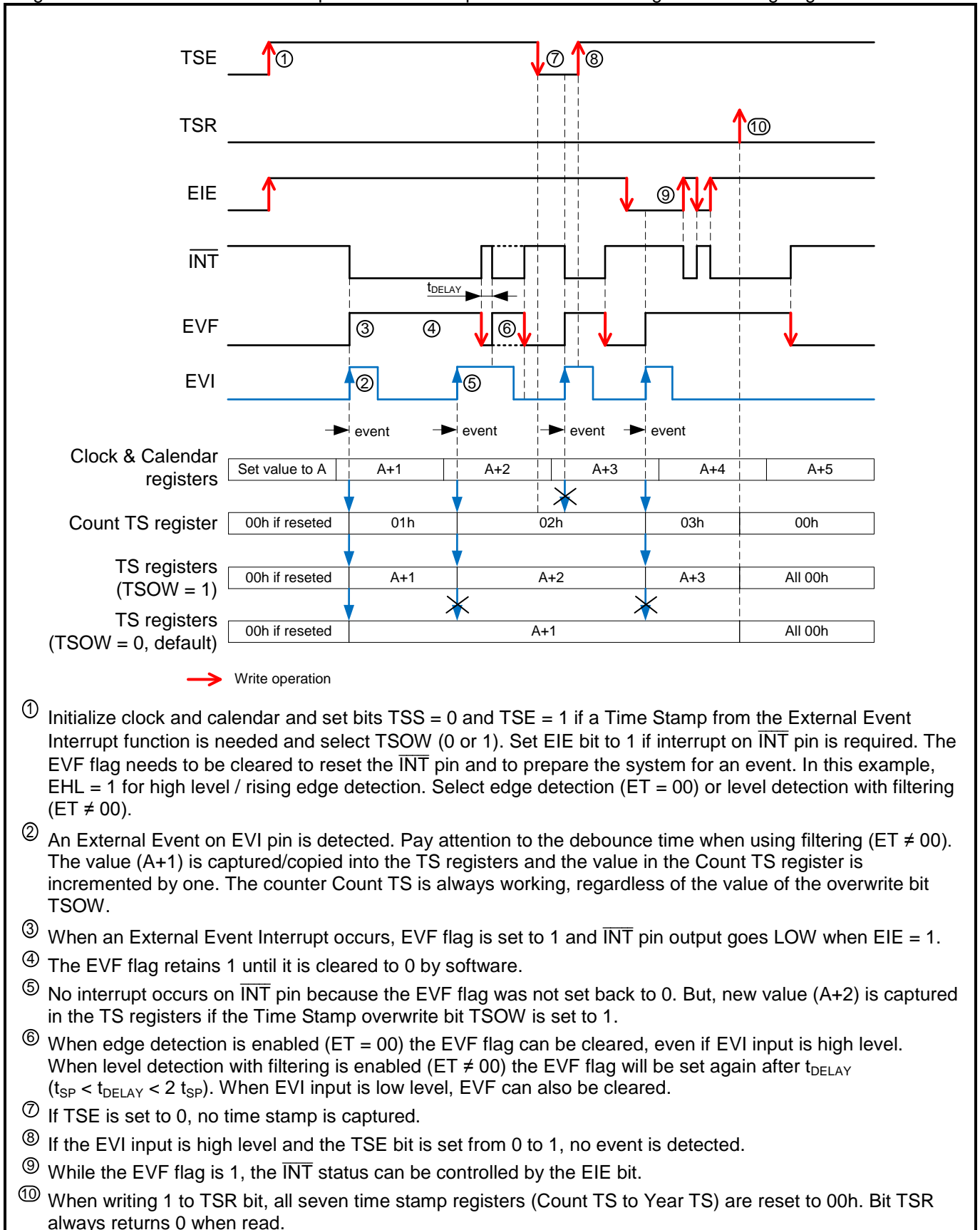

#### 4.11.2. USE OF THE EXTERNAL EVENT INTERRUPT

The following registers and bits are related to the External Event Interrupt, Time Stamp and Automatic Clock output function:

- Seconds Register (00h) (see CLOCK REGISTERS)
- Minutes Register (01h) (see CLOCK REGISTERS)
- Hours Register (02h) (see CLOCK REGISTERS)
- Date Register (04h) (see CALENDAR REGISTERS)
- Month Register (05h) (see CALENDAR REGISTERS)
- Year Register (06h) (see CALENDAR REGISTERS)
- Count TS Register (14h) (see TIME STAMP REGISTERS)
- Seconds TS (15h) (see TIME STAMP REGISTERS)
- Minutes TS (16h) (see TIME STAMP REGISTERS)
- Hours TS (17h) (see TIME STAMP REGISTERS)
- Date TS (18h) (see TIME STAMP REGISTERS)
- Month TS (19h) (see TIME STAMP REGISTERS)
- Year TS (1A) (see TIME STAMP REGISTERS)
- EVF flag (see STATUS AND CONTROL REGISTERS, 0Eh – Status)
- TSE, EIE and 12\_24 bits (see STATUS AND CONTROL REGISTERS, 10h – Control 2)
- CEIE bit (see STATUS AND CONTROL REGISTERS, 12h – Clock Interrupt Mask)
- EHL bit, ET field, TSR bit, TSOW bit and TSS bit (see EVENT CONTROL REGISTER, 13h – Event Control)

Prior to entering any timer settings for the event interrupt, it is recommended to write a 0 to the TSE and EIE bit to prevent inadvertent interrupts on  $\overline{\text{INT}}$  pin.

Note that changing TSS bit value from 1 to 0 before clearing TSE and EIE can create unwanted interrupts (according to EHL bit, but regardless of the status of the ET field).

Procedure to use the External Event Interrupt, Time Stamp and Automatic Clock output function:

1. Initialize bits TSE and EIE to 0.
2. Clear flag EVF to 0.
3. Set TSS bit to 0 to select External Event on EVI pin as Time Stamp and Interrupt source.
4. Set EHL bit to 1 or 0 to choose high or low level (or rising or falling edge) detection on pin EVI.
5. Select EDGE DETECTION (ET = 00) or LEVEL DETECTION WITH FILTERING (ET ≠ 00).
6. Set TSOW bit to 1 if the last occurred event has to be recorded and TS registers are overwritten.  
Hint: The counter Count TS is always working, independent of the settings of the overwrite bit TSOW.
7. Write 1 to TSR bit, to reset all Time Stamp registers to 00h. Bit TSR always returns 0 when read.
8. Set CEIE bit to 1 to enable clock output when external event occurs. See also CLOCK OUTPUT SCHEME.
9. Set TSE bit to 1 if you want to enable the Time Stamp function.
10. Set EIE bit to 1 if you want to get a hardware interrupt on  $\overline{\text{INT}}$  pin.



4.11.3. EDGE DETECTION (ET = 00)

Example with rising edge detection and interrupt output:

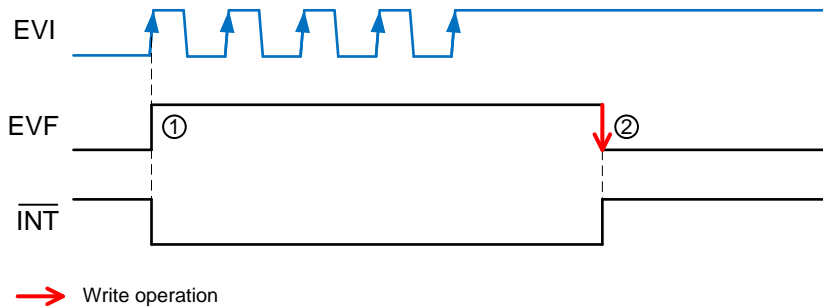

Settings: EHL = 1, ET = 00, TSS = 0, EIE = 1.

- ① When a rising edge on EVI pin is detected, the EVF flag is set to 1 and the  $\overline{\text{INT}}$  output pin goes LOW.
- ② If the  $\overline{\text{INT}}$  pin is LOW, its status changes as soon as the EVF flag is cleared to 0, even if EVI input is high level.

4.11.4. LEVEL DETECTION WITH FILTERING (ET ≠ 00)

Example with high level detection and interrupt output:

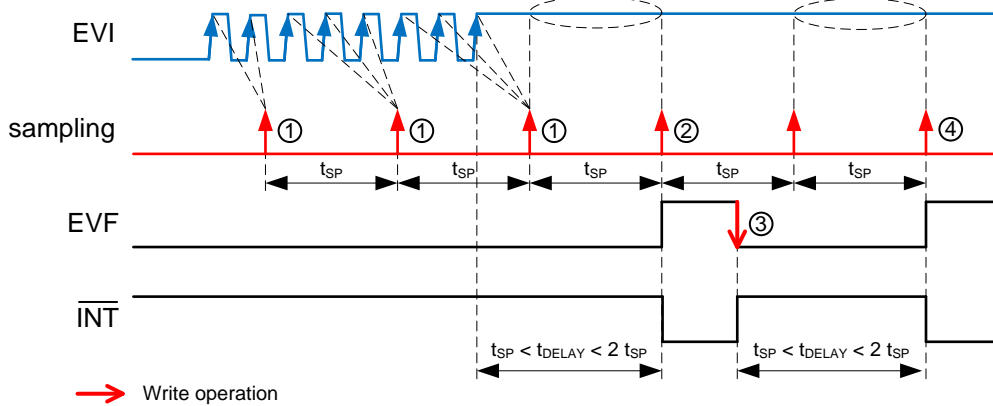

Settings: EHL = 1, ET ≠ 00, TSS = 0, EIE = 1.

Available sampling periods for the digital debounce filtering:

- ET = 01,  $t_{\text{SP}} = 3.9 \text{ ms}$
- ET = 10,  $t_{\text{SP}} = 15.6 \text{ ms}$
- ET = 11,  $t_{\text{SP}} = 125.0 \text{ ms}$

- ① From the previous sampling pulse to this sampling pulse, no stable high level was detected.
- ② If a stable high level on EVI pin during one sampling period is detected, the EVF flag is set to 1 and the  $\overline{\text{INT}}$  output pin goes LOW. The delay time  $t_{\text{DELAY}}$  is between  $t_{\text{SP}}$  and  $2 t_{\text{SP}}$ .
- ③ If the  $\overline{\text{INT}}$  pin is LOW, its status changes as soon as the EVF flag is cleared to 0.
- ④ When the high level on EVI pin remains stable, again, the EVF flag is set to 1 and the  $\overline{\text{INT}}$  output pin goes LOW. The delay time  $t_{\text{DELAY}}$  is again between  $t_{\text{SP}}$  and  $2 t_{\text{SP}}$ .

#### 4.12. AUTOMATIC BACKUP SWITCHOVER INTERRUPT FUNCTION

The Automatic Backup Switchover Interrupt function generates an interrupt event when the BSM field (EEPROM 37h) is set to 01 (DSM) or 11 (LSM) and a switchover from VDD Power state to VBACKUP Power state occurs.

If enabled (TSS = 1, TSE = 1, BSIE = 1 and BSF flag was cleared to 0 before) and a Backup Switchover is detected, the clock and calendar registers are captured and copied into the Time Stamp registers, the  $\overline{\text{INT}}$  is issued and the BSF flag is set to 1 to indicate that a Backup Switchover has occurred.

Similar to the External Event Interrupt Function, clock output on CLKOUT pin can be controlled by the Automatic Backup Switchover Interrupt function. When bits TSS and EIE are set to 1, the internal event interrupt signal (EI) created by the Automatic Backup Switchover function can be used to enable the clock output on CLKOUT pin automatically.

If enabled (TSS, EIE, CEIE, CLKIE and CLKOE are set to 1 and a frequency is selected in the FD field), when again in VDD Power state, CLKOUT pin outputs the frequency (see INTERRUPT SCHEME and CLOCK OUTPUT SCHEME).

Note that a debounce logic provides a debounce time  $t_{\text{DEB}}$  of 122  $\mu\text{s}$  to 183  $\mu\text{s}$ , which will filter  $V_{\text{DD}}$  oscillation when the backup switchover will switch back from  $V_{\text{BACKUP}}$  to  $V_{\text{DD}}$  (see AUTOMATIC BACKUP SWITCHOVER FUNCTION).  $I^2C$  access is possible in VDD Power state after the debounce time  $t_{\text{DEB}}$ .

Note that the FEDE bit (EEPROM 37h) should always be set to 1, so that Fast Edge Detection ( $\geq 7$  V/ms) is enabled (see EEPROM BACKUP REGISTER). FEDE = 1 is the default value on delivery.

4.12.1. AUTOMATIC BACKUP SWITCHOVER DIAGRAM

Diagram of the Automatic Backup Switchover Interrupt function:

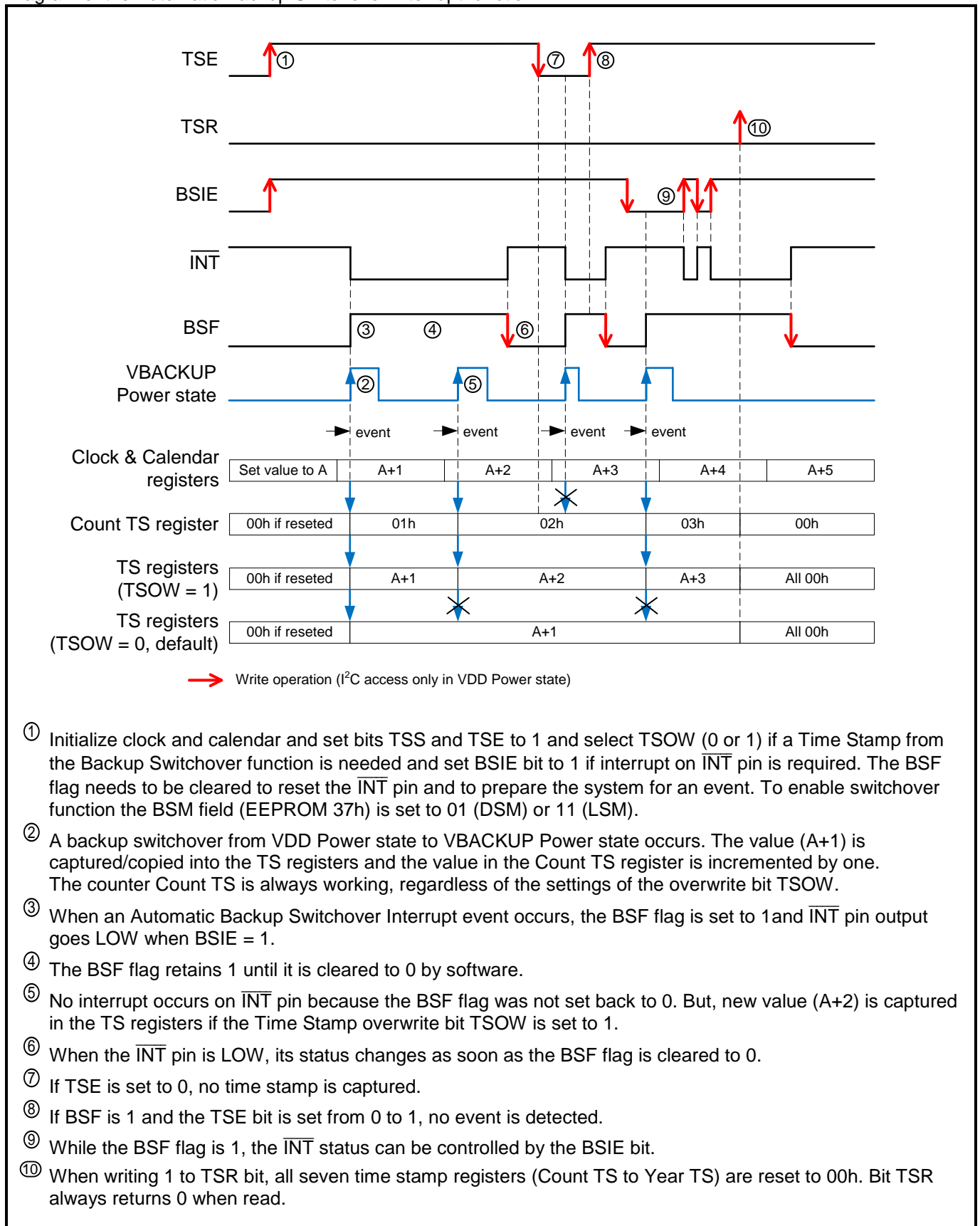

#### 4.12.2. USE OF THE AUTOMATIC BACKUP SWITCHOVER INTERRUPT

The following registers and bits are related to the Automatic Backup Switchover Interrupt, Time Stamp and Automatic Clock output function:

- Seconds Register (00h) (see CLOCK REGISTERS)
- Minutes Register (01h) (see CLOCK REGISTERS)
- Hours Register (02h) (see CLOCK REGISTERS)
- Date Register (04h) (see CALENDAR REGISTERS)
- Month Register (05h) (see CALENDAR REGISTERS)
- Year Register (06h) (see CALENDAR REGISTERS)
- Count TS (14h) (see TIME STAMP REGISTERS)
- Seconds TS (15h) (see TIME STAMP REGISTERS)
- Minutes TS (16h) (see TIME STAMP REGISTERS)
- Hours TS (17h) (see TIME STAMP REGISTERS)
- Date TS (18h) (see TIME STAMP REGISTERS)
- Month TS (19h) (see TIME STAMP REGISTERS)
- Year TS (1A) (see TIME STAMP REGISTERS)
- BSF flag (see STATUS AND CONTROL REGISTERS, 0Eh – Status)
- TSE, EIE and 12\_24 bits (see STATUS AND CONTROL REGISTERS, 10h – Control 2)
- CEIE bit (see STATUS AND CONTROL REGISTERS, 12h – Clock Interrupt Mask)
- TSR bit, TSOW bit and TSS bit (see EVENT CONTROL REGISTER, 13h – Event Control)
- BSIE bit, FEDE bit and BSM field (see EEPROM BACKUP REGISTER, 37h – EEPROM Backup)

Prior to entering any other settings, it is recommended to write a 0 to the TSE and BSIE bit to prevent inadvertent interrupts on  $\overline{\text{INT}}$  pin.

Procedure to use the Automatic Backup Switchover Interrupt, Time Stamp and Automatic Clock output function:

1. Initialize bits TSE and BSIE to 0.
2. Clear flag BSF to 0.
3. Set TSS bit to 1 to select Backup Switchover as Time Stamp and Interrupt source.
4. Set TSOW bit to 1 if the last occurred event has to be recorded and TS registers are overwritten.  
Hint: The counter Count TS is always working, independent of the settings of the overwrite bit TSOW.
5. Write 1 to TSR bit, to reset all Time Stamp registers to 00h. Bit TSR always returns 0 when read.
6. Set CEIE bit to 1 to enable clock output when a backup switchover occurs.  
Caution: This function is only working with the Automatic Backup Switchover function when bits TSS and TSE are set to 1. See also CLOCK OUTPUT SCHEME.
7. Set TSE bit to 1 if you want to enable the Time Stamp function.
8. The FEDE bit should always be set to 1, so that Fast Edge Detection ( $\geq 7$  V/ms) is enabled.
9. Set the BSIE bit to 1 if you want to get a hardware interrupt on  $\overline{\text{INT}}$  pin.
10. Choose the switchover mode (DSM or LSM) and write the corresponding value in the BSM field.

See also EEPROM READ/WRITE CONDITIONS.

### 4.13. POWER ON RESET INTERRUPT FUNCTION

The Power On Reset Interrupt function is enabled by the PORIE bit (EEPROM 35h). The PORIE bit has to be set beforehand in the EEPROM, not in the RAM (see EEPROM READ/WRITE).

When voltage drop below  $V_{POR}$  is detected ( $V_{DD} < V_{POR}$ ) the PORF flag is set to 1 to indicate that a Power On Reset has occurred and when the PORIE bit is 1 the  $\overline{INT}$  pin goes to low level.

A PORF value of 1 indicates also that the time information is corrupted. The value 1 is retained until a 0 is written by the user.

#### 4.13.1. POWER ON RESET DIAGRAM

Diagram of the Power On Reset Interrupt function:

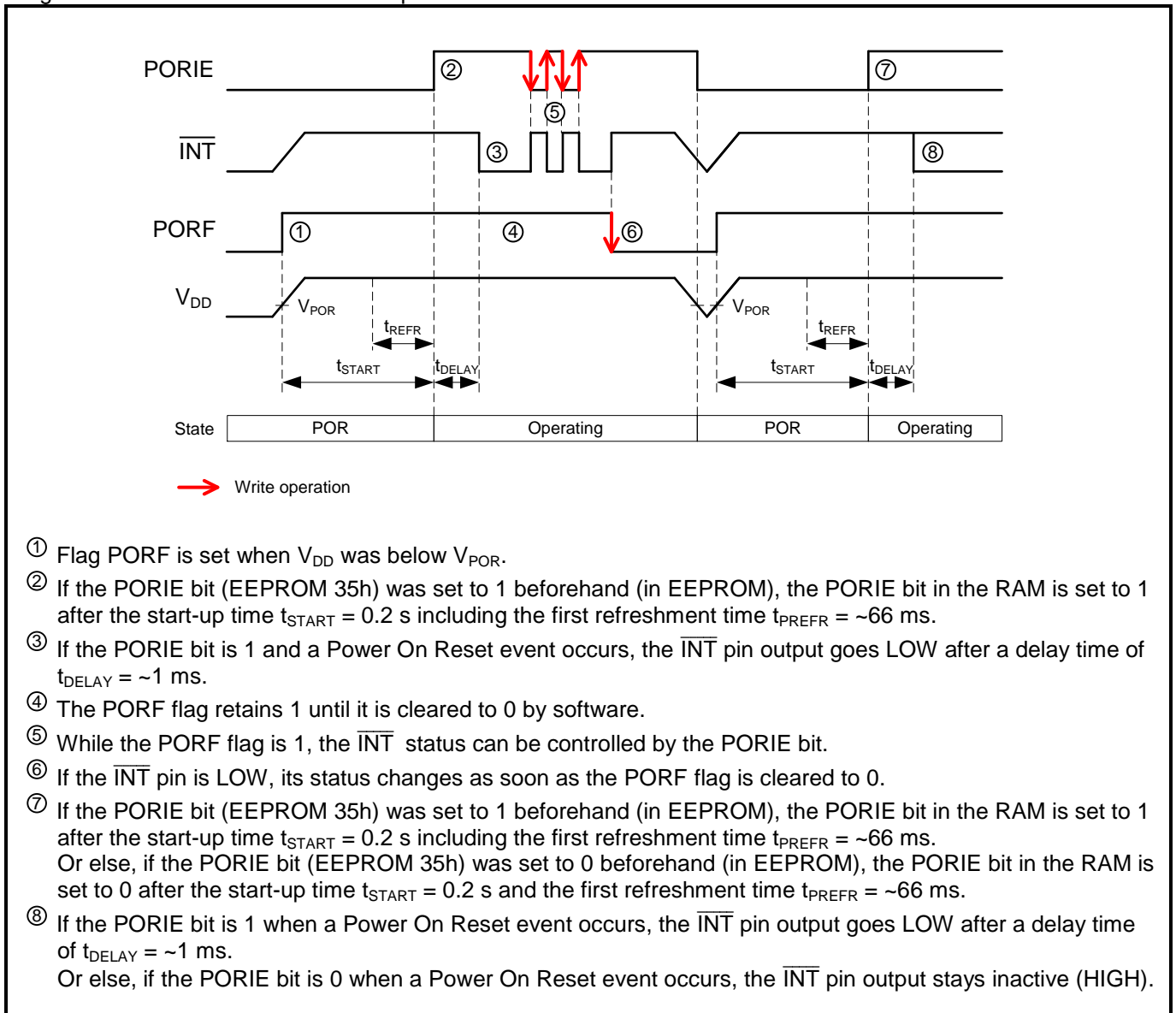

#### 4.13.2. USE OF THE POWER ON RESET INTERRUPT

The following registers and bits are related to the Power On Reset Interrupt function (including EEPROM handling):

- PORF flag and EEbusy bit (see STATUS AND CONTROL REGISTERS, 0Eh – Status)
- EERD bit (see STATUS AND CONTROL REGISTERS, 0Fh – Control 1)
- EE Address register (25h) (see EEPROM MEMORY CONTROL REGISTERS)
- EE Data register (26h) (see EEPROM MEMORY CONTROL REGISTERS)
- EE Command register (27h) (see EEPROM MEMORY CONTROL REGISTERS)
- PORIE bit (see EEPROM CLKOUT REGISTER, 35h – EEPROM Clkout)

The PORIE bit has to be set beforehand in the EEPROM, not in the RAM (see EEPROM READ/WRITE).

Procedure to use the Power On Reset Interrupt function:

1. In the EEPROM, set the PORIE bit to 1 if you want to get a hardware interrupt on  $\overline{\text{INT}}$  pin at the next Power On Reset event. Procedure according to EEPROM READ/WRITE.
2. The first interrupt will occur after the next POR event.

#### 4.14. TIME STAMP FUNCTION

The Time Stamp function is enabled by the control bit TSE. Sources are the External Event Interrupt function (TSS = 0) or the Automatic Backup Switchover Interrupt function (TSS = 1).

If a source is enabled and an event is detected, the Time Stamp (TS) registers are recorded. When the TSOW bit is set to 0 and the EVF flag was cleared to 0 before, only one (the first) event is recorded. When the TSOW bit is set to 1, the last event is recorded (EVF flag does not need to be cleared). The counter Count TS is always working, independent of the settings of the overwrite bit TSOW.

- When writing 1 to TSR bit, all seven time stamp registers (Count TS to Year TS) are reset to 00h. Bit TSR always returns 0 when read.
- Before starting the Time Stamp function, it is recommended to write 0 to the TSE bit and 1 to TSR bit.
- When writing 1 to the RESET bit or when writing to the Seconds register, Time Stamp capture/copy does not occur. Bit RESET always returns 0 when read.
- Note that changing TSS bit value from 1 to 0 before clearing TSE can create unwanted Time Stamp capture/copy from the External Event Interrupt function (according to EHL bit, but regardless of the status of the ET field).

Procedure for using the Time Stamp function:

1. Initialize bits TSE and EIE to 0.
2. Select TSOW (0 or 1), clear EVF and BSF.
3. Write 1 to TSR bit, to reset all Time Stamp registers to 00h. Bit TSR always returns 0 when read.
4. Select the External Event Interrupt function (TSS = 0) or the Automatic Backup Switchover Interrupt function (TSS = 1) as time stamp source and initialize the appropriate function (see EXTERNAL EVENT INTERRUPT FUNCTION or AUTOMATIC BACKUP SWITCHOVER INTERRUPT FUNCTION).
5. Set the TSE bit to 1 to enable the Time Stamp function.

Hint: The  $\overline{\text{INT}}$  signal is issued when EIE (RAM) or BSIE (EEPROM 37h) bit is set to 1. The EVF or BSF flag is set to 1 to indicate that a corresponding event has occurred.

Caution: Because the EVF flag is internally used for the identification of a First Event detection it is set by an event from the External Event Interrupt function (TSS = 0, TSE = 1) or by an event of the Backup Switchover Interrupt function (TSS = 1, TSE = 1). See also the following scheme:

Time Stamp scheme:

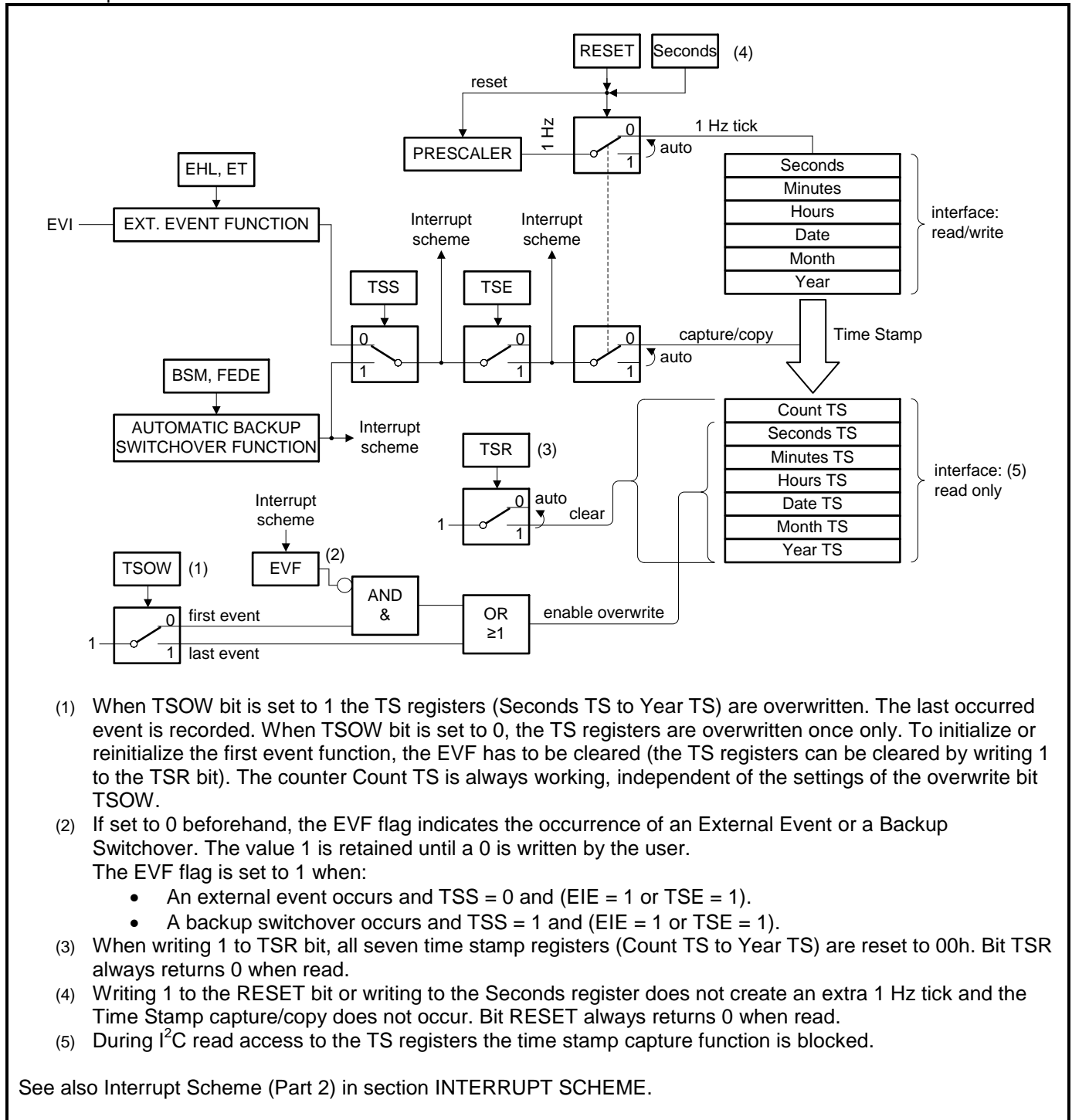



## 4.15. FREQUENCY OFFSET CORRECTION

An aging adjustment or accuracy tuning can be done with the EEOffset value. The correction is made purely digital and has only the effect of shifting the time vs. temperature curve vertically up or down. It has no effect on the time vs. temperature characteristics of the final frequency. The EEOffset value contains a two's complement number with a range of +255 to -256 adjustment steps. The minimal correction step (one LSB) is  $\pm 1 / (16384 \times 64) = \pm 0.9537$  ppm and the maximum correction range is from +243.2 ppm to -244.1 ppm. The compensation period is 64 seconds.

Note that the signed offset value EEOffset corresponds to the correction value of the measured frequency (32.768 kHz). The non-volatile user programmable EEOffset value (factory calibrated time accuracy is  $\pm 1$  ppm @ 25°C) can be adjusted by the user. See chapters below.

Caution: Bits 8 to 1 of the EEOffset value are in the register 36h – EEPROM Offset (see EEPROM OFFSET REGISTER). Bit 0 (LSB) of the EEOffset value is in the register 37h – EEPROM Backup (see EEPROM BACKUP REGISTER).

### 4.15.1. EEOFFSET VALUE DETERMINATION

The EEOffset value is determined by the following process:

1. Select the 32.768 kHz frequency on the CLKOUT pin.  
(If another frequency than 32.768 kHz is selected, the EEOffset value has to be set to 0 so that the uncorrected frequency can be measured, and the following calculations have to be adapted.)
2. Measure the frequency  $F_{meas}$  at CLKOUT pin in Hz.
3. Compute the offset value required in ppm:  $POffset = ((F_{meas} - 32768) / 32768 \times 1'000'000)$
4. Compute the offset value in steps:  $Offset = POffset / (1 / (16384 \times 64) \text{ in ppm}) = POffset / (0.9537 \text{ ppm})$
5. If  $Offset > 256$ , the frequency is too high to be corrected.
6. Else if  $1 \leq Offset \leq 256$  (correction is  $-1 \geq OffsetCorr. \geq -256$ ),  $\rightarrow$  set  $EEOffset = 512 - Offset$
7. Else if  $-255 \leq Offset \leq 0$  (correction is  $+255 \leq OffsetCorr. \leq 0$ ),  $\rightarrow$  set  $EEOffset = - Offset$
8. Else the frequency is too low to be corrected.

Examples:

- If 32768.48 Hz is measured when the 32.768 kHz clock is selected, the offset is +0.48 Hz, which is  $+0.48 \text{ Hz} / 32768 \text{ Hz} \times 1'000'000 = +14.648$  ppm. The Offset value in steps is then calculated as follows:  $+14.648 \text{ ppm} / 0.9537 \text{ ppm} = +15.36$ , the rounded integral part is 15 (the offset correction is -15 steps). The unsigned EEOffset value is then:  $512 - 15 = +497$ . In binary,  $EEOffset = 111110001$ .
- If 32767.52 Hz is measured when the 32.768 kHz clock is selected, the offset is -0.48 Hz, which is  $-0.48 \text{ Hz} / 32768 \text{ Hz} \times 1'000'000 = -14.648$  ppm. The Offset value in steps is then calculated as follows:  $-14.648 \text{ ppm} / 0.9537 \text{ ppm} = -15.36$ , the rounded integral part is -15 (the offset correction is +15 steps). The EEOffset value is then:  $-(-15) = +15$ . In binary,  $EEOffset = 000001111$ .

### 4.15.2. VERIFICATION OF THE CORRECTED TIME ACCURACY

The offset correction can be verified by the following process:

1. Enter the calculated EEOffset value (see EEOFFSET VALUE DETERMINATION).
2. Select the 1 Hz frequency on the CLKOUT pin (if another frequency is selected the following calculations have to be adapted).
3. Measure every period during one compensation period of 64 seconds at CLKOUT pin.
4. Calculate the average frequency  $F_{meas\_aver}$  in Hz.
5. Compute the new achieved offset value in ppm:  $POffset = ((F_{meas\_aver} - 1) / 1 \times 1'000'000)$

## 4.16. UNIX TIME COUNTER

The UNIX Time counter is a 32-bit counter, unsigned integer, which rolls over to 00000000h when reaching the value FFFFFFFFh. The 4 bytes are fully readable and writable. The counter source clock is the digitally offset compensated 1 Hz tick.

### 4.16.1. SETTING THE UNIX TIME

During I<sup>2</sup>C write access with an access time smaller than 950 ms the UNIX registers (UNIX Time 0 to UNIX Time 3) are blocked. Unlike to the setting of the clock and calendar registers, after I<sup>2</sup>C STOP condition a possibly memorized 1 Hz tick can be lost.

Advantage of register blocking:

- Prevents faulty writing to the UNIX registers during an I<sup>2</sup>C write access (no incrementing of UNIX registers during the write access).
- No reading is needed for control. The written data are coherent.

If the I<sup>2</sup>C write access takes longer than 950 ms the I<sup>2</sup>C bus interface is reset by the internal bus timeout function. In this case the previous UNIX value is maintained and the UNIX increment (1 Hz tick) continues to operate normally (a pending 1 Hz tick can be lost). Restarting of communications begins with transfer of the START condition again.

Since when writing immediately to the four UNIX registers, a possibly memorized 1 Hz tick can be lost, it is recommended to make a reset of the prescaler before setting the UNIX time (see RESET BIT FUNCTION). The 32-bit UNIX counter value itself does not change during reset. The time between the reset and the I<sup>2</sup>C STOP after writing the UNIX time should be within 950 ms. See diagram below.

Advantage of this method:

- No 1 Hz tick will be lost during write access to the four UNIX registers.
- Prevents unwanted difference of one second between Seconds register and UNIX time.

Example for setting the UNIX time using the reset function:

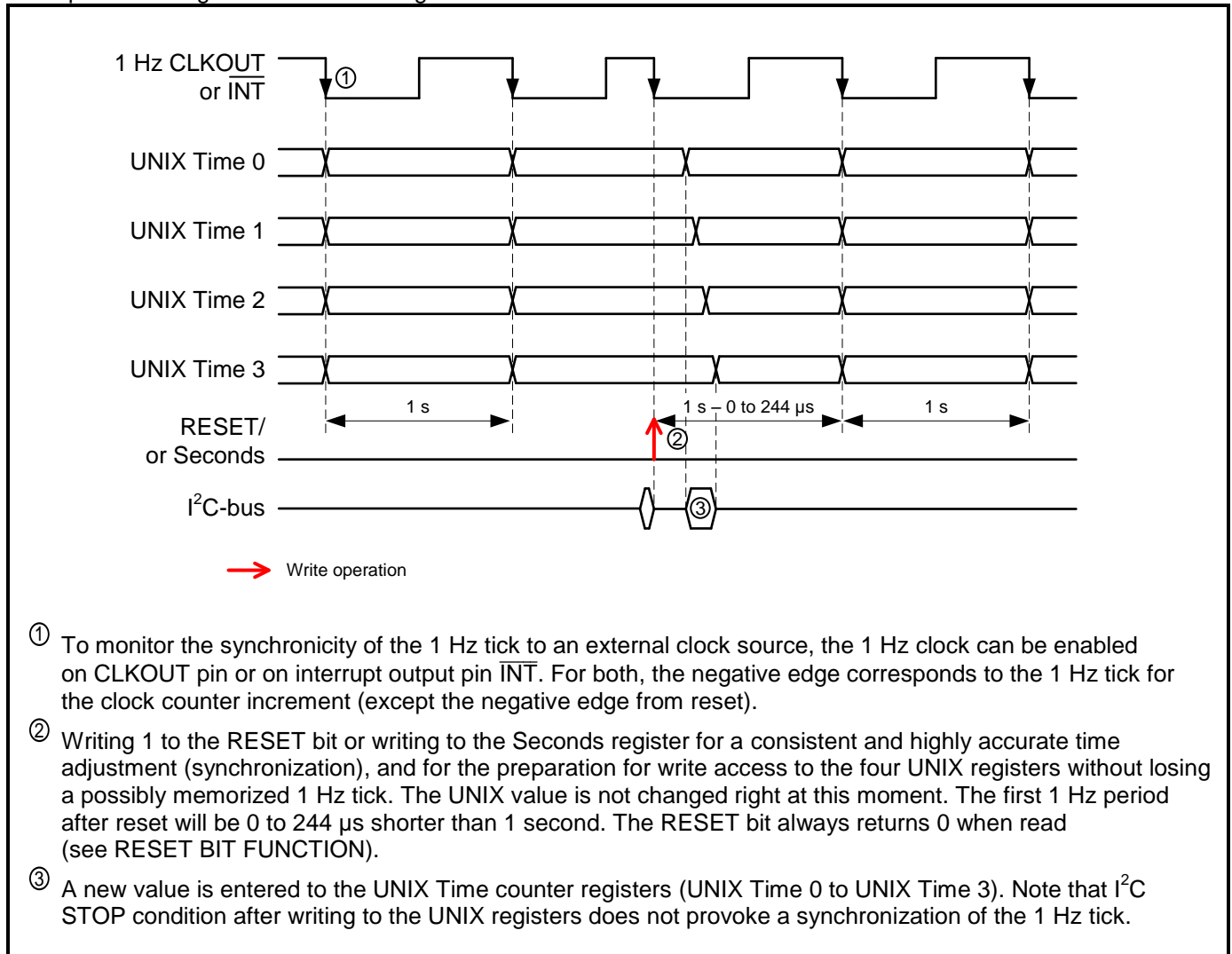

#### 4.16.2. READING THE UNIX TIME

During I<sup>2</sup>C read access with an access time smaller than 950 ms the UNIX registers (UNIX Time 0 to UNIX Time 3) are fully readable but not blocked. Like to the reading of the clock and calendar registers, after I<sup>2</sup>C STOP condition a possibly memorized 1 Hz tick is realized.

Advantage of the memorized 1 Hz tick:

- After reading, one memorized 1 Hz tick is handled. The UNIX time is updated.

If the I<sup>2</sup>C read access takes longer than 950 ms the I<sup>2</sup>C bus interface is reset by the internal bus timeout function. In this case all UNIX data that is read has a value of FFh, the pending 1 Hz tick is realized and the UNIX increment (1 Hz tick) continues to operate normally. Restarting of communications begins with transfer of the START condition again.

Two methods for reading the UNIX time are recommended:

1. Read the four registers (UNIX Time 0 to UNIX Time 3) twice and check for consistent results.
2. Generate 1 Hz interrupt on  $\overline{\text{INT}}$  pin with PERIODIC TIME UPDATE INTERRUPT FUNCTION for the MCU, when can be read. The time between the interrupt event and the I<sup>2</sup>C STOP after reading the UNIX time should be within 950 ms. No second reading needed.

### 4.17. RESET BIT FUNCTION

The RESET bit is used for a software-based accurate and safe starting of the time circuits (synchronization). Writing to the Seconds register has the same effect.

When writing 1 to the RESET bit or when writing to the Seconds register, the clock prescaler frequencies for 8192 Hz to 1 Hz are reset and an eventual present memorized 1 Hz update is also reset. The RESET bit always returns 0 when read. Because the upper stage of the prescaler is not reset (16.384 kHz) and the I<sup>2</sup>C interface is asynchronous, the first 1 Hz period after reset will be 0 to 244 μs shorter than 1 second. Resetting the prescaler will have an influence on the length of current clock period on all subsequent peripherals (clock and calendar, CLKOUT clock, timer clock, update timer clock, UNIX clock, EVI input filter).

Writing 1 to the RESET bit or writing to the Seconds register will not affect the CLKOUT of the 32.768 kHz (see also CLKOUT FREQUENCY SELECTION).

Scheme of the reset function:

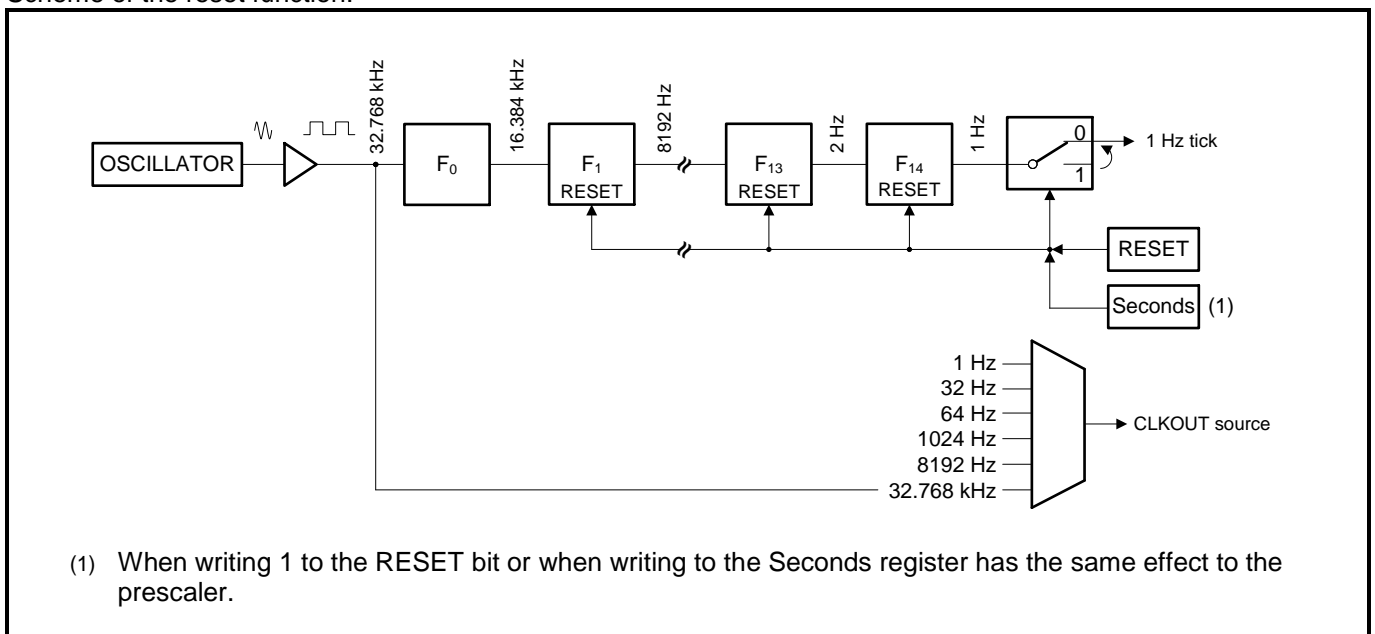

Procedure for setting the clock and calendar values using the RESET bit function:

1. Write the desired clock and calendar values within 950 ms to the registers (seconds, minutes, hours, weekday, date, month and year).
2. Write 1 to the RESET bit or write a value to the Seconds register for a synchronized start of the time circuits (1 Hz tick). The RESET bit always returns 0 when read.

See also sections SETTING THE TIME and SETTING THE UNIX TIME.

Timing of the reset function:

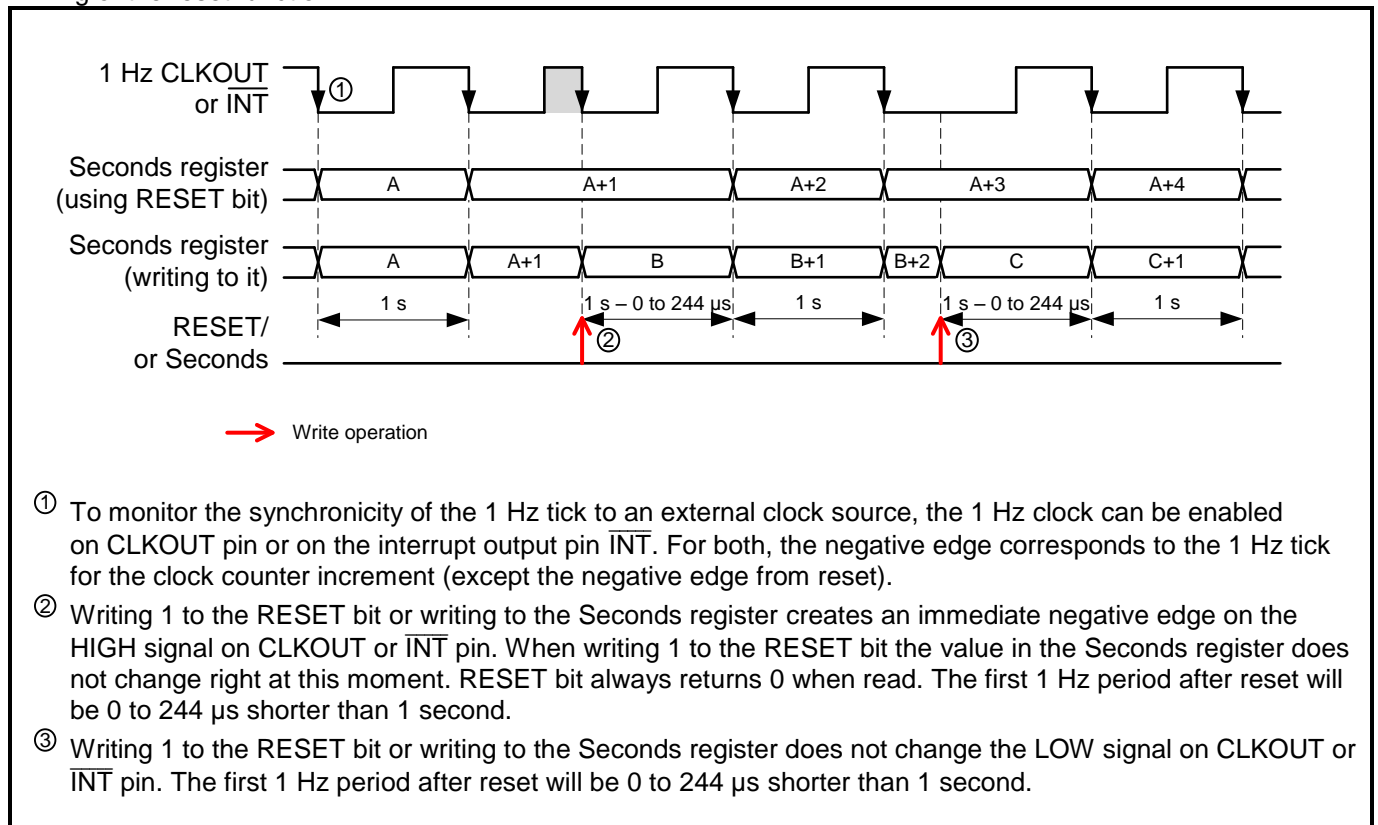

## 4.18. USER PROGRAMMABLE PASSWORD

After a Power up and the first refreshment of  $t_{\text{PREFR}} = \sim 66 \text{ ms}$ , the PW0 to PW3 registers are reset to 00h and the EEPWE (EEPROM 30h) and EEPW 0 to EEPW 3 values (EEPROM 31h to 34h) are copied from the EEPROM. The first four Password registers (PW0 to PW3), in case of the use of the function (enabled by writing 255 into the EEPROM Password Enable register EEPWE), are used to write the 32-Bit Password necessary to be able to write in all writable registers (time, control and configuration registers). This 32-Bit Password is compared to the 32 bits stored in the RAM mirror of the EEPROM Password registers EEPW 0 to EEPW 3 (see PASSWORD REGISTERS, EEPROM PASSWORD ENABLE REGISTER and EEPROM PASSWORD REGISTERS).

Caution: The number of possible passwords is  $2^{32} \approx 4.3 \times 10^9 = 4.3 \text{ billion}$ .

### 4.18.1. ENABLE/DISABLE WRITE PROTECTION

If the write protection function is enabled by writing 255 in register EEPWE (EEPROM 30h), it remains possible to read all the registers except the EEPROM registers. The EEPROM registers cannot be read because it cannot be written to the EE Address and EE Command registers. If the function is not enabled, read and write are possible for all corresponding registers.

If the write protection function is enabled, it is necessary to first write the correct 32-Bit Password PW (PW = EEPW) before any attempt to write in the RAM registers (Unlock), and to read and write in the EEPROM registers. Once the user is finished with the write access and subsequently the write protection is still enabled or enabled again (by writing 255 in EEPROM register EEPWE), it is necessary to write an incorrect password (PW  $\neq$  EEPW) into the Password registers PW0 to PW3 in order to write-protect (Lock) the registers. See program sequences below and FLOWCHART.

Enable write protection:

1. WP-Registers are Not write-protected (EEPWE  $\neq$  255)
2. Reference password is stored in registers EEPW 0 to EEPW 3
3. Disable automatic refresh by setting EERD = 1
4. Enable password function by entering EEPWE = 255 (RAM)
5. Update EEPROM (all Configuration RAM  $\rightarrow$  EEPROM) by setting EECMD = 00h followed by 11h
6. Enable automatic refresh by setting EERD = 0
7. Enter an incorrect password PW (PW  $\neq$  EEPW) to lock the device
8. WP-Registers are Write-protected by password (EEPWE = 255)

Disable write protection:

1. WP-Registers are Write-protected by password (EEPWE = 255)
2. Reference password is stored in registers EEPW 0 to EEPW 3
3. Enter the correct password PW (PW = EEPW) to unlock write protection
4. Disable automatic refresh by setting EERD = 1
5. Disable password function by entering EEPWE  $\neq$  255 (RAM)
6. Update EEPROM (all Configuration RAM  $\rightarrow$  EEPROM) by setting EECMD = 00h followed by 11h
7. Enable automatic refresh by setting EERD = 0
8. WP-Registers are Not write-protected (EEPWE  $\neq$  255)

Hint: EEPROM from reference password in registers EEPW 0 to EEPW 3 can be READ with the Read one EEPROM byte command (EECMD = 00h followed by 22h) when Unlocked (registers not write-protected). This option is useful if it is not certain which password is written in the EEPW before the write protection function is enabled. The RAM mirror from the EEPW registers can never be read.

#### 4.18.2. CHANGING PASSWORD

To code a new password, the user has to first enter the current (correct) password into the Password registers (PW0 to PW3) if the registers are write protected, and writing a value not equal to all 1 (value  $\neq$  255) in the EEPWE register (EEPROM 30h) to unlock write protection, and then write the new one in the registers EEPW 0 to EEPW 3 (EEPROM 31h to 34h) and writing all 1 (value = 255) in the EEPWE register to enable password function. See program sequences below and FLOWCHART.

Change password if password function is enabled (EEPWE = 255):

1. WP-Registers are Write-protected by old reference password in registers EEPW 0 to EEPW 3
2. Enter old, correct password PW (PW = EEPW) to unlock write protection
3. Disable automatic refresh by setting EERD = 1
4. Disable password function by entering EEPWE  $\neq$  255 (RAM)
5. Define a new reference password EEPW in registers EEPW 0 to EEPW 3 (RAM)
6. Enable the password function by entering EEPWE = 255 (RAM)
7. Update EEPROM (all Configuration RAM  $\rightarrow$  EEPROM) by setting EECMD = 00h followed by 11h
8. Enable automatic refresh by setting EERD = 0
9. Enter an incorrect password PW (PW  $\neq$  EEPW) to lock the device
10. WP-Registers are Write-protected by new reference password in registers EEPW 0 to EEPW 3

Change password if password function is disabled (EEPWE  $\neq$  255):

1. Old reference password is stored in registers EEPW 0 to EEPW 3
2. Disable automatic refresh by setting EERD = 1
3. Define a new reference password EEPW in registers EEPW 0 to EEPW 3 (RAM)
4. Update EEPROM (all Configuration RAM  $\rightarrow$  EEPROM) by setting EECMD = 00h followed by 11h
5. Enable automatic refresh by setting EERD = 0
6. New reference password is stored in registers EEPW 0 to EEPW 3

Note that the EEPROM password EEPW = 00000000h is not a real password, because after POR refresh the password PW is also 00000000h (PW = EEPW) and although the password function is enabled (EEPWE = 255) the PW-Registers are NOT write-protected.



4.18.3. FLOWCHART

The following Flowchart describes the programming of the enabling and disabling of the register write protection by user password and the changing of the user password and other Configuration EEPROM registers (35h – 37h) if write protection is enabled or disabled. In this example the Update EEPROM command (EECMD = 00h followed by 11h) is used to write (store) data from all Configuration RAM mirror bytes (address 30h to 37h) into the corresponding Configuration EEPROM bytes. See also USE OF THE CONFIGURATION REGISTERS.

User programmable password flowchart:

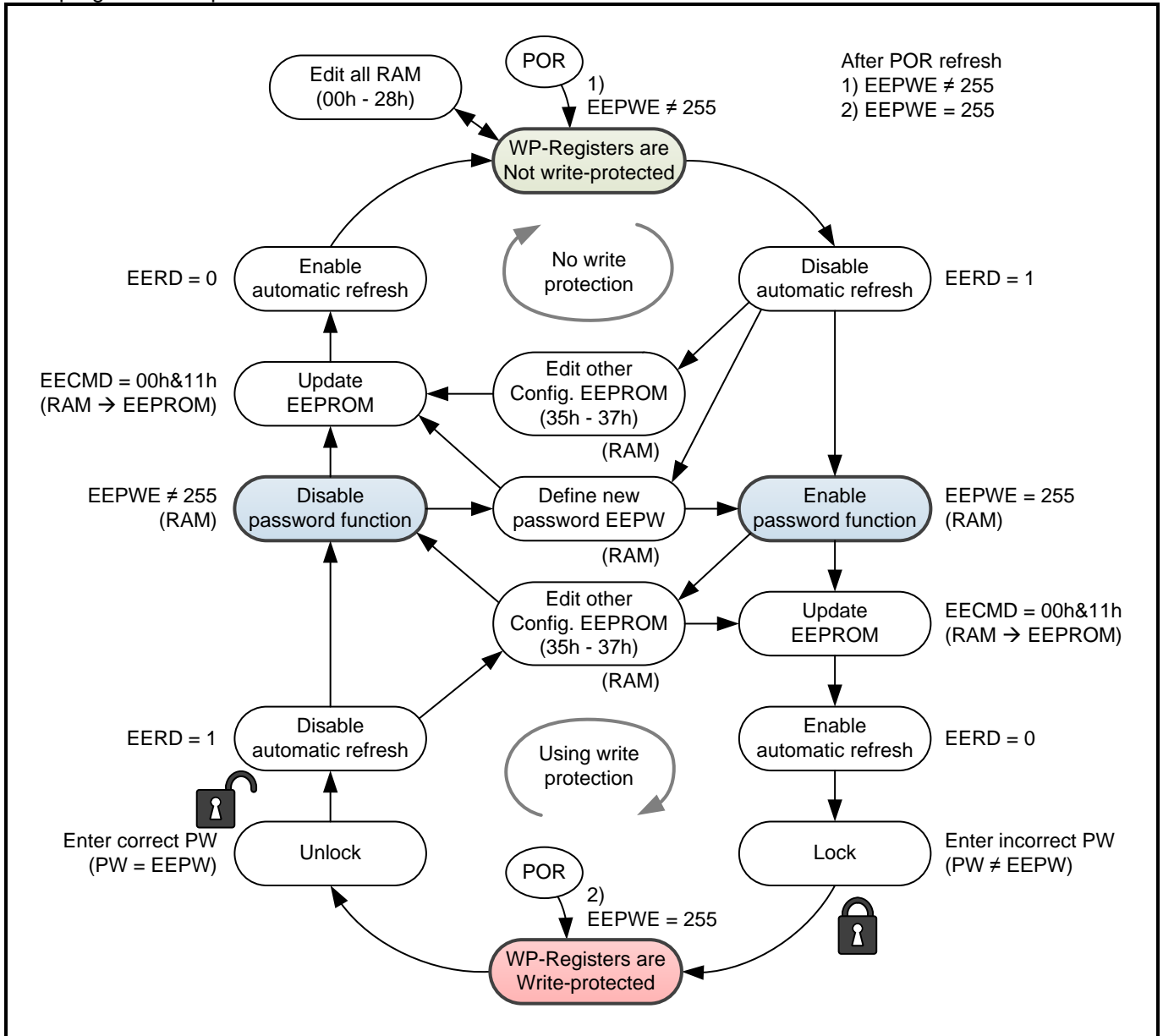

## 5. I<sup>2</sup>C INTERFACE

The I<sup>2</sup>C interface is for bidirectional, two-line communication between different ICs or modules. The RV-3028-C7 is accessed at addresses A4h/A5h, and supports Fast Mode (up to 400 kHz). The I<sup>2</sup>C interface consists of two lines: one bi-directional data line (SDA) and one clock line (SCL). Both lines are connected to a positive supply via pull-up resistors. Data transfer is initiated only when the interface is not busy.

### 5.1. BIT TRANSFER

One data bit is transferred during each clock pulse. The data on the SDA line remains stable during the HIGH period of the clock pulse, as changes in the data line at this time are interpreted as control signals. Data changes should be executed during the LOW period of the clock pulse (see Figure below).

Bit transfer:

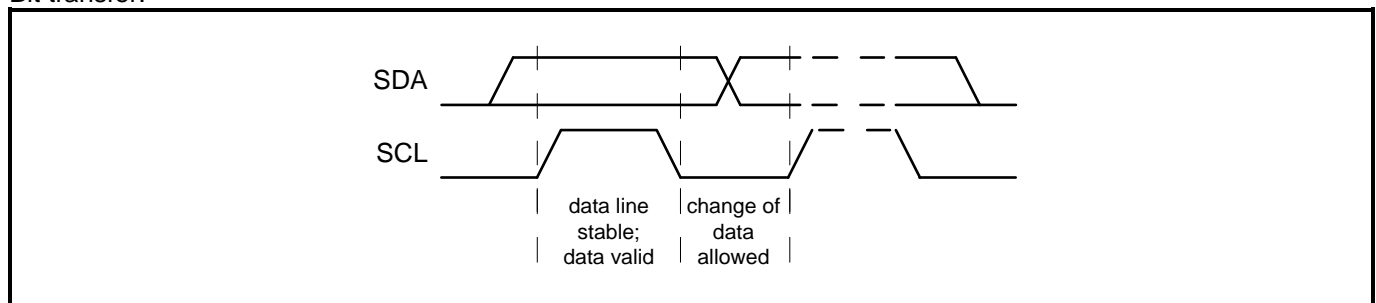

### 5.2. START AND STOP CONDITIONS

Both data and clock lines remain HIGH when the bus is not busy. A HIGH-to-LOW transition of the data line, while the clock is HIGH, is defined as the START condition (S). A LOW-to-HIGH transition of the data line, while the clock is HIGH, is defined as the STOP condition (P) (see Figure below).

Definition of START and STOP conditions:

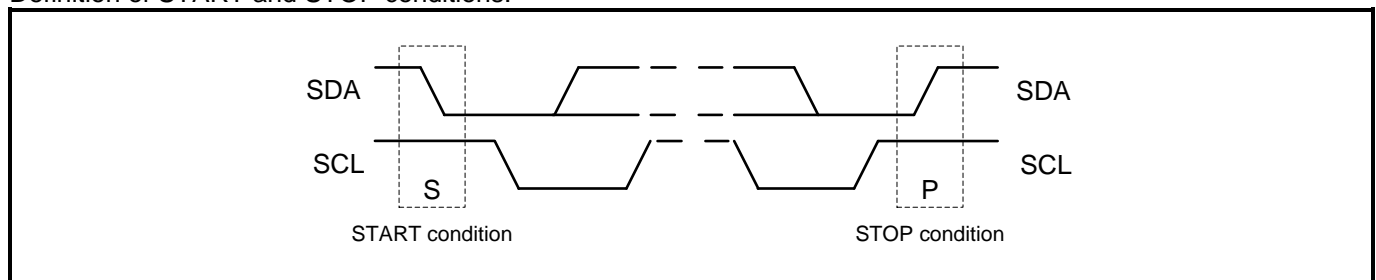

A START condition which occurs after a previous START but before a STOP is called a Repeated START condition, and functions exactly like a normal STOP followed by a normal START.

#### Caution:

When communicating with the RV-3028-C7 module, the series of operations from transmitting the START condition to transmitting the STOP condition should occur within **950 ms**.

If this series of operations requires **950 ms or longer**, the I<sup>2</sup>C-bus interface will be automatically cleared and set to standby mode by the bus timeout function of the RV-3028-C7. Note with caution that both write and read operations are invalid for communications that occur during or after this auto clearing operation. When writing: no acknowledge will occur. When reading: FFh will be read.

Restarting of communications begins with transfer of the START condition again.

The I<sup>2</sup>C auto increment Address Pointer is not reset by the I<sup>2</sup>C STOP condition nor by the internal stop forced after timeout.

### 5.3. DATA VALID

After a START condition, SDA is stable for the duration of the high period of SCL. The data on SDA may be changed during the low period of SCL. There is one clock pulse per bit of data. Each data transfer is initiated with a START condition and terminated with a STOP condition. The number of data bytes transferred between the START and STOP conditions is not limited (however, the transfer time must be no longer than 950 ms). The information is transmitted byte-wise and each receiver acknowledges with a ninth bit.

### 5.4. SYSTEM CONFIGURATION

Since multiple devices can be connected with the I<sup>2</sup>C-bus, all I<sup>2</sup>C-bus devices have a fixed and unique device number built-in to allow individual addressing of each device.

The device that controls the I<sup>2</sup>C-bus is the Master; the devices which are controlled by the Master are the Slaves. A device generating a message is a Transmitter; a device receiving a message is the Receiver. The RV-3028-C7 acts as a Slave-Receiver or Slave-Transmitter.

Before any data is transmitted on the I<sup>2</sup>C-bus, the device which should respond is addressed first. The addressing is always carried out with the first byte transmitted after the START procedure. The clock signal SCL is only an input signal, but the data signal SDA is a bidirectional line.

System configuration:

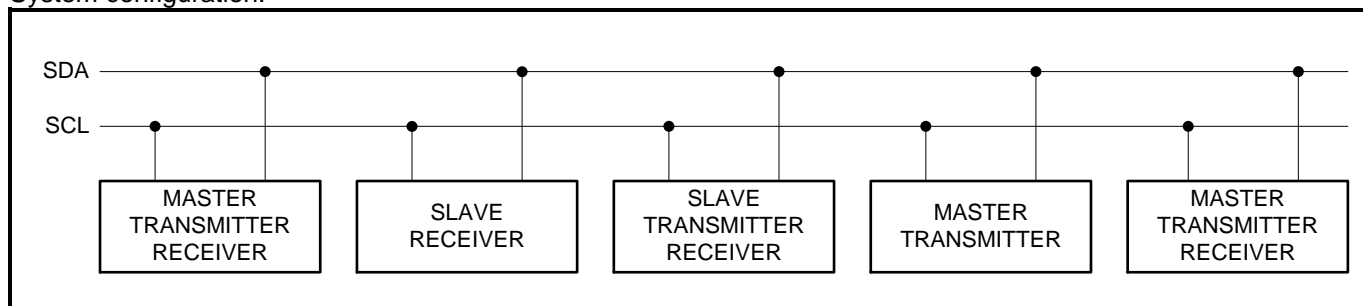

## 5.5. ACKNOWLEDGE

The number of data bytes transferred between the START and STOP conditions from transmitter to receiver is unlimited (however, the transfer time must be no longer than 950 ms). Each byte of eight bits is followed by an acknowledge cycle.

- A slave receiver, which is addressed, must generate an acknowledge cycle after the reception of each byte.
- Also a master receiver must generate an acknowledge cycle after the reception of each byte that has been clocked out of the slave transmitter.
- The device that acknowledges must pull-down the SDA line during the acknowledge clock pulse, so that the SDA line is stable LOW during the HIGH period of the acknowledge-related clock pulse (set-up and hold times must be taken into consideration).
- A master receiver must signal an end of data to the transmitter by not generating an acknowledge cycle on the last byte that has been clocked out of the slave. In this event the transmitter must leave the data line HIGH to enable the master to generate a STOP condition.

Data transfer and acknowledge on the I<sup>2</sup>C-bus:

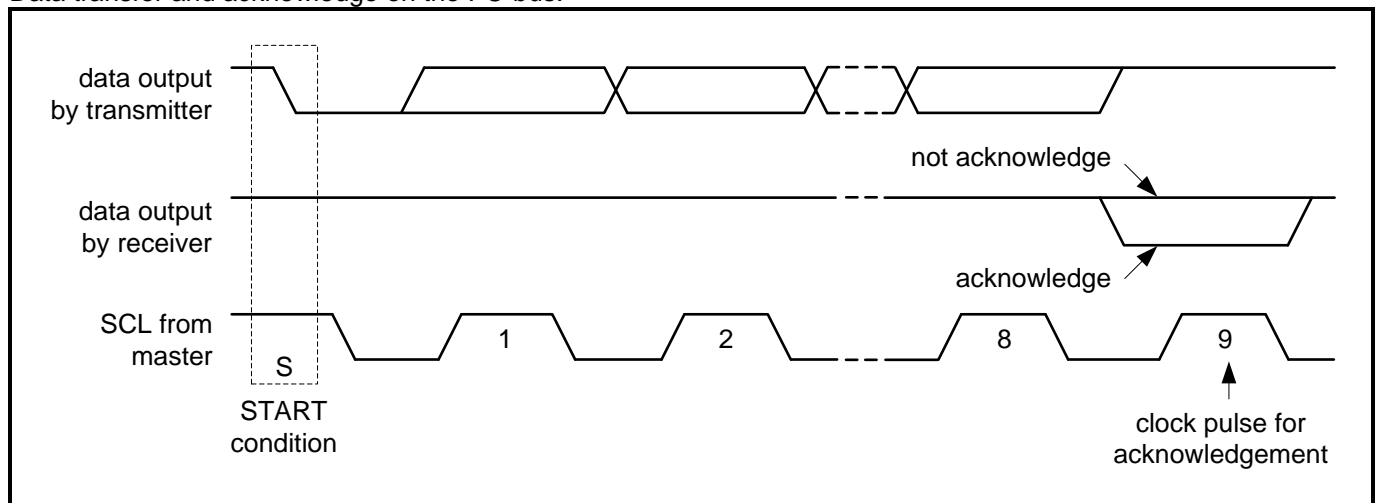

### 5.6. SLAVE ADDRESS

On the I<sup>2</sup>C-bus the 7-bit slave address 1010010b is reserved for the RV-3028-C7. The entire I<sup>2</sup>C-bus slave address byte is shown in the following table.

Slave address							R/ $\bar{W}$	Transfer data
Bit 7	Bit 6	Bit 5	Bit 4	Bit 3	Bit 2	Bit 1	Bit 0	
1	0	1	0	0	1	0	1 (R)	A5h (read)
							0 ( $\bar{W}$ )	A4h (write)

After a START condition, the I<sup>2</sup>C slave address has to be sent to the RV-3028-C7 device. The R/ $\bar{W}$  bit defines the direction of the following single or multiple byte data transfer. The 7-bit address is transmitted MSB first. If this address is 1010010b, the RV-3028-C7 is selected, the eighth bit indicates a read (R/ $\bar{W}$  = 1) or a write (R/ $\bar{W}$  = 0) operation (results in A5h or A4h) and the RV-3028-C7 supplies the ACK. The RV-3028-C7 ignores all other address values and does not respond with an ACK.

In the write operation, a data transfer is terminated by sending either the STOP condition or the START condition of the next data transfer.

### 5.7. WRITE OPERATION

Master transmits to Slave-Receiver at specified address. The Register Address is an 8-bit value that defines which register is to be accessed next. After writing one byte, the Register Address is automatically incremented by 1.

Master writes to slave RV-3028-C7 at specific address:

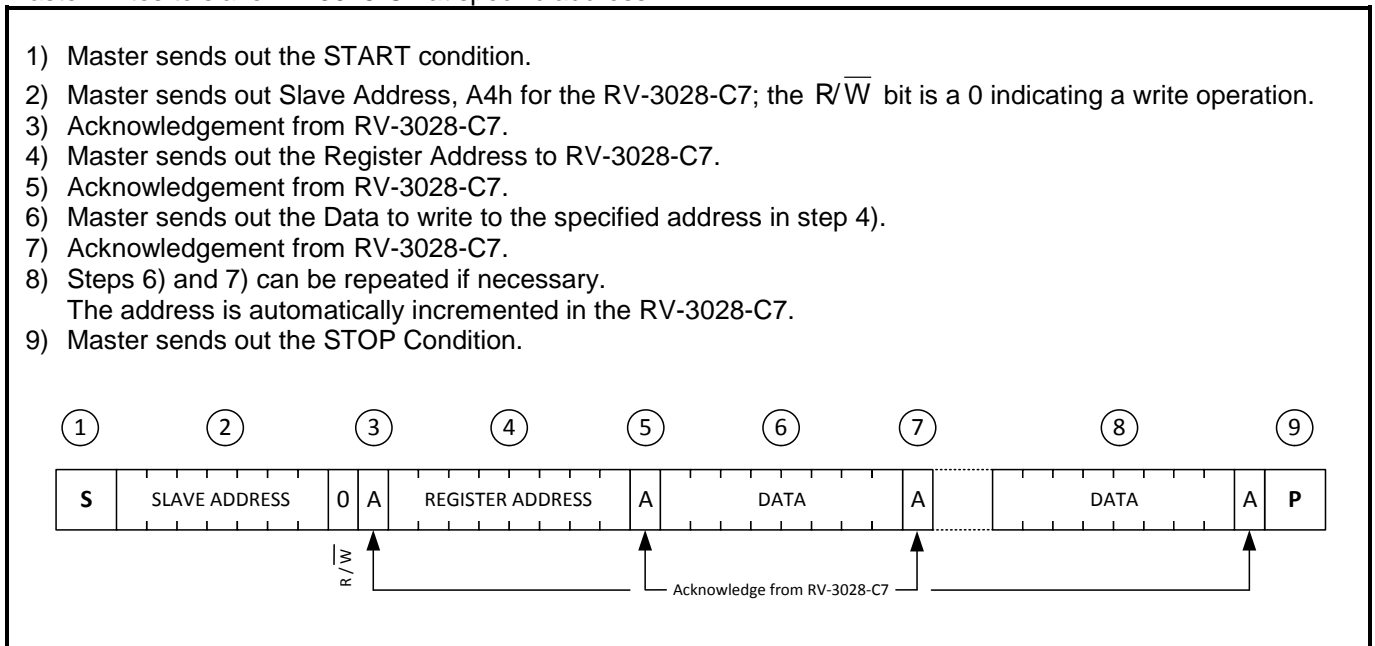

### 5.8. READ OPERATION AT SPECIFIC ADDRESS

Master reads data from slave RV-3028-C7 at specific address:

- 1) Master sends out the START condition.
- 2) Master sends out Slave Address, A4h for the RV-3028-C7; the  $\overline{R/W}$  bit is a 0 indicating a write operation.
- 3) Acknowledgement from RV-3028-C7.
- 4) Master sends out the Register Address to RV-3028-C7.
- 5) Acknowledgement from RV-3028-C7.
- 6) Master sends out the Repeated START condition (or STOP condition followed by START condition)
- 7) Master sends out Slave Address, A5h for the RV-3028-C7; the  $\overline{R/W}$  bit is a 1 indicating a read operation.
- 8) Acknowledgement from RV-3028-C7.
- At this point, the Master becomes a Receiver and the Slave becomes the Transmitter.
- 9) The Slave sends out the Data from the Register Address specified in step 4).
- 10) Acknowledgement from Master.
- 11) Steps 9) and 10) can be repeated if necessary.
- The address is automatically incremented in the RV-3028-C7.
- 12) The Master, addressed as Receiver, can stop data transmission by not generating an acknowledge on the last byte that has been sent from the Slave-Transmitter. In this event, the Slave-Transmitter must leave the data line HIGH to enable the Master to generate a STOP condition.
- 13) Master sends out the STOP condition.

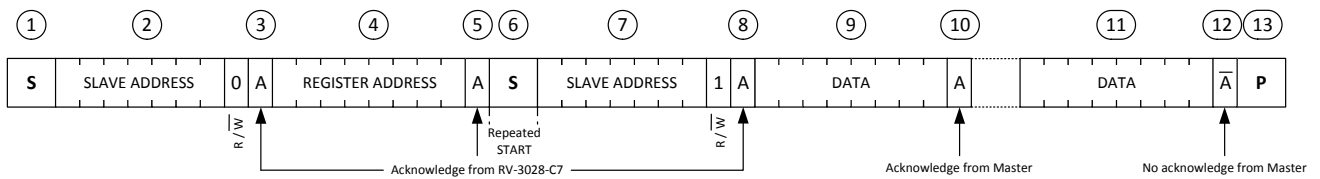

### 5.9. READ OPERATION

Master reads data from slave RV-3028-C7 immediately after first byte:

- 1) Master sends out the START condition.
- 2) Master sends out Slave Address, A5h for the RV-3028-C7; the  $\overline{R/W}$  bit is a 1 indicating a read operation.
- 3) Acknowledgement from RV-3028-C7.
- At this point, the Master becomes a Receiver and the Slave becomes the Transmitter.
- 4) The RV-3028-C7 sends out the Data from the last accessed Register Address incremented by 1.
- 5) Acknowledgement from Master.
- 6) Steps 4) and 5) can be repeated if necessary.
- The address is automatically incremented in the RV-3028-C7.
- 7) The Master, addressed as Receiver, can stop data transmission by not generating an acknowledge on the last byte that has been sent from the Slave-Transmitter. In this event, the Slave-Transmitter must leave the data line HIGH to enable the Master to generate a STOP condition.
- 8) Master sends out the STOP condition.

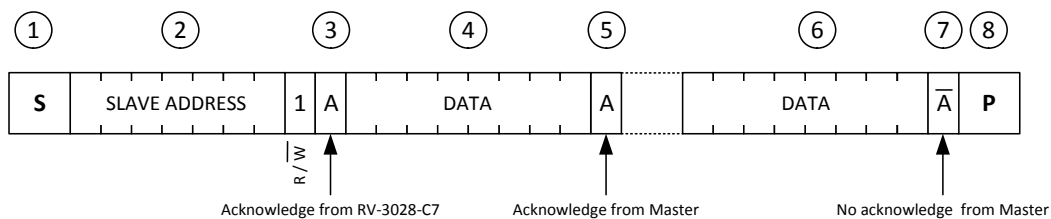

### 5.10. I<sup>2</sup>C-BUS IN SWITCHOVER CONDITION

To save power when the RV-3028-C7 is in VBACKUP Power state the bus I<sup>2</sup>C-bus interface is automatically disabled (high impedance) and reset. Therefore the communication via I<sup>2</sup>C interface should be terminated before the supply is switched from V<sub>DD</sub> to V<sub>BACKUP</sub>. When the bus communication is not terminated in a proper way, the time counters get corrupted.

If the I<sup>2</sup>C communication was terminated uncontrolled, the I<sup>2</sup>C has to be reinitialized by sending a STOP followed by a START after the device switched back from VBACKUP Power state to VDD Power state.

## 6. ELECTRICAL SPECIFICATIONS

### 6.1. ABSOLUTE MAXIMUM RATINGS

The following Table lists the absolute maximum ratings.

Absolute Maximum Ratings according to IEC 60134:

SYMBOL	PARAMETER	CONDITIONS	MIN	TYP	MAX	UNIT
V <sub>DD</sub>	Power Supply Voltage		-0.3		6.0	V
V <sub>I</sub>	Input voltage	Input Pin	-0.3		V <sub>DD</sub> +0.3	V
V <sub>O</sub>	Output voltage	Output Pin	-0.3		V <sub>DD</sub> +0.3	V
I <sub>I</sub>	Input current		-10		10	mA
I <sub>O</sub>	Output current		-10		10	mA
V <sub>ESD</sub>	ESD Voltage	HBM <sup>(1)</sup>			±2000	V
		MM <sup>(2)</sup>			±200	V
I <sub>LU</sub>	Latch-up Current	Jedec <sup>(3)</sup>			±100	mA
T <sub>OPR</sub>	Operating Temperature		-40		85	°C
T <sub>STO</sub>	Storage Temperature		-55		125	°C
T <sub>PEAK</sub>	Maximum reflow condition	JEDEC J-STD-020C			265	°C

<sup>(1)</sup> HBM: Human Body Model, according to JESD22-A114.

<sup>(2)</sup> MM: Machine Model, according to JESD22-A115.

<sup>(3)</sup> Latch-up testing, according to JESD78., Class I (room temperature), level A (100 mA)



## 6.2. OPERATING PARAMETERS

For this Table,  $T_A = -40$  to  $+85^\circ\text{C}$  unless otherwise indicated.  $V_{DD} = 1.2$  to  $5.5$  V, TYP values at  $25^\circ\text{C}$  and  $3.0$  V.

Operating Parameters:

SYMBOL	PARAMETER	CONDITIONS	MIN	TYP	MAX	UNIT
<b>Supplies</b>						
$V_{DD}$	Power Supply Voltage	Time-keeping mode <sup>(1)</sup>	1.1		5.5	V
		Minimum time-keeping voltage <sup>(1)</sup>		0.9	1.1	
		I <sup>2</sup> C-bus (100 kHz)	1.2		5.5	
		I <sup>2</sup> C-bus (400 kHz)	2.0		5.5	
$V_{BACKUP}$	Backup Supply Voltage		1.1		5.5	V
$I_{DD}$	$V_{DD}$ supply current timekeeping I <sup>2</sup> C-bus inactive, CLKOUT disabled, average current	$V_{DD} = 1.1$ V <sup>(2)</sup> , $T_A = 25^\circ\text{C}$		45	60	nA
		$V_{DD} = 3.0$ V <sup>(2)</sup> , $T_A = 25^\circ\text{C}$		45	60	
		$V_{DD} = 5.0$ V <sup>(2)</sup> , $T_A = 25^\circ\text{C}$		45	66	
		$V_{DD} = 1.1$ V <sup>(2)</sup> , $T_{OPR} = -40$ to $+85^\circ\text{C}$			300	
		$V_{DD} = 3.0$ V <sup>(2)</sup> , $T_{OPR} = -40$ to $+85^\circ\text{C}$			330	
		$V_{DD} = 5.0$ V <sup>(2)</sup> , $T_{OPR} = -40$ to $+85^\circ\text{C}$			400	
$I_{DD:I2C}$	$V_{DD}$ supply current during I <sup>2</sup> C burst read/write, CLKOUT disabled	$V_{DD} = 1.2$ V, SCL = 100 kHz <sup>(3)</sup>		2	15	$\mu\text{A}$
		$V_{DD} = 3.0$ V, SCL = 400 kHz <sup>(3)</sup>		5	40	
		$V_{DD} = 5.0$ V, SCL = 400 kHz <sup>(3)</sup>		7	60	
$I_{DD:DSM}$	$V_{DD}$ supply current in Direct Switching Mode I <sup>2</sup> C-bus inactive, CLKOUT disabled	$V_{DD} = 3.0$ V, $T_A = 25^\circ\text{C}$ , $V_{BACKUP} < V_{DD}$		95	150	nA
$I_{DD:LSM}$	$V_{DD}$ supply current in Level Switching Mode I <sup>2</sup> C-bus inactive, CLKOUT disabled	$V_{DD} = 3.0$ V, $T_A = 25^\circ\text{C}$		115	180	
$I_{BACKUP:DSM}$	$V_{BACKUP}$ supply current in Direct Switching Mode	$V_{BACKUP} = 3.0$ V, $T_A = 25^\circ\text{C}$ , $V_{DD} < V_{BACKUP}$		95	150	
$I_{BACKUP:LSM}$	$V_{BACKUP}$ supply current in Level Switching Mode	$V_{BACKUP} = 3.0$ V, $T_A = 25^\circ\text{C}$ , $V_{DD} < V_{THLSM}$ (2.0 V)		115	180	
$\Delta I_{DD:CK32}$	Additional $V_{DD}$ supply current <sup>(4)</sup>	$V_{DD} = 3.0$ V, $F_{CLKOUT} = 32.768$ kHz, $C_L = 10$ pF		1		$\mu\text{A}$
$\Delta I_{DD:CK1024}$		$V_{DD} = 3.0$ V, $F_{CLKOUT} = 1024$ Hz, $C_L = 10$ pF		30		nA
$\Delta I_{DD:CK1}$		$V_{DD} = 3.0$ V, $F_{CLKOUT} = 1$ Hz, $C_L = 10$ pF		0.03		
<p>(1) Clocks operating and RAM registers retained.</p> <p>(2) All inputs and outputs are at 0 V or <math>V_{DD}</math>.</p> <p>(3) 2.2 k<math>\Omega</math> pull-up resistors on SCL/SDA, excluding external peripherals and pull-up resistor current. All other inputs (besides SDA and SCL) are at 0 V or <math>V_{DD}</math>. Test conditions: Continuous burst read/write, 55h data pattern, 25 <math>\mu\text{s}</math> between each data byte, 20 pF load on each bus pin.</p> <p>(4) When CLKOUT is enabled the additional <math>V_{DD}</math> supply current <math>\Delta I_{DD}</math> can be calculated as follows:  <math>\Delta I_{DD} = C_L \times V_{DD} \times f_{OUT}</math>, e.g. <math>\Delta I_{DD} = 10</math> pF <math>\times</math> 3.0 V <math>\times</math> 32'768 Hz = 980 nA <math>\approx</math> 1 <math>\mu\text{A}</math></p>						

For this Table,  $T_A = -40$  to  $+85^\circ\text{C}$  unless otherwise indicated.  $V_{DD} = 1.2$  to  $5.5$  V, TYP values at  $25^\circ\text{C}$  and  $3.0$  V.

## Operating Parameters (continued):

SYMBOL	PARAMETER	CONDITIONS	MIN	TYP	MAX	UNIT
<b>Inputs</b>						
$V_{IL}$	LOW level input voltage	$V_{DD} = 1.1$ V to $5.5$ V Pins: SCL, SDA, EVI			$0.2 V_{DD}$	V
$V_{IH}$	HIGH level input voltage		$0.8 V_{DD}$			V
$I_{LEAK}$	Input leakage current	$V_{SS} \leq V_I \leq V_{DD}$	-0.5		0.5	$\mu\text{A}$
$C_I$	Input capacitance	$V_{DD} = 3.0$ V, $T_A = 25^\circ\text{C}$ $f = 1$ MHz			7	pF
<b>Outputs</b>						
$V_{OL:CLK}$	LOW level output voltage CLKOUT	$V_{DD} = 1.1$ V, $I_{OL} = -0.1$ mA			0.1	V
		$V_{DD} = 3.0$ V, $I_{OL} = -1.0$ mA			0.3	
		$V_{DD} = 5.0$ V, $I_{OL} = -1.0$ mA			0.5	
$V_{OH:CLK}$	HIGH level output voltage CLKOUT	$V_{DD} = 1.1$ V, $I_{OH} = 0.1$ mA	1.0			V
		$V_{DD} = 3.0$ V, $I_{OH} = 1.0$ mA	2.7			
		$V_{DD} = 5.0$ V, $I_{OH} = 1.0$ mA	4.5			
$V_{OL}$	LOW level output voltage Pins: SDA, INT	$V_{DD} = 1.2$ V, $I_{OL} = -0.5$ mA			0.4	V
		$V_{DD} = 3.0$ V, $I_{OL} = -3.0$ mA			0.4	
		$V_{DD} = 5.0$ V, $I_{OL} = -3.0$ mA			0.3	
$I_{OLEAK}$	Output leakage current	$V_O = V_{DD}$ or $V_{SS}$	-0.5		0.5	$\mu\text{A}$
$C_{OUT}$	Output capacitance	$V_{DD} = 3.0$ V, $T_A = 25^\circ\text{C}$ $f = 1$ MHz			7	pF
<b>Power On Reset</b>						
$V_{POR}$	POR detection threshold		0.75	0.8	0.85	V
<b>Trickle charger</b>						
TCR 3 k $\Omega$	Current limiting resistor	$V_{DD} = 5.0$ V, $V_{BACKUP} = 3.0$ V, including internal schottky diode	2	3	4	k $\Omega$
TCR 5 k $\Omega$			4.5	5.5	6.25	
TCR 9 k $\Omega$			7.5	9.3	11.6	
TCR 15 k $\Omega$			12.5	15.5	17.4	
$V_F$	Schottky diode voltage drop			0.25		V
<b>Switchover</b>						
$V_{HYST:DSM}$	Switchover hysteresis in Direct Switching Mode	$V_{DD}$ with respect to $V_{BACKUP} = 3.0$ V, $V_{DD}$ slew rate = $\pm 1$ V/ms $T_{OPR} = -40$ to $+85^\circ\text{C}$		60		mV
$V_{TH:LSM}$	Backup switchover threshold voltage in Level Switching Mode	$V_{DD}$ falls below $V_{TH:LSM}$	1.8	2.0	2.2	V
$V_{HYST:LSM}$	Switchover hysteresis in Level Switching Mode	$V_{DD}$ with respect to $V_{BACKUP} = 3.0$ V, $V_{DD}$ slew rate = $\pm 1$ V/ms $T_{OPR} = -40$ to $+85^\circ\text{C}$		100		mV
<b>EEPROM Characteristics</b>						
$V_{DD:READ}$	$V_{DD}$ read voltage	$V_{DD}$ Power state	1.1			V
$V_{DD:WRITE}$	$V_{DD}$ write voltage		1.5			
$t_{PREFR}$	POR refresh time	At power up		66		ms
$t_{AREFR}$	Automatic refresh time	Each 24 hours, EERD = 0		3.5		
$t_{UPDATE}$	Update time	EECMD = 11h		63		
$t_{REFR}$	Refresh time	EECMD = 12h		3.5		
$t_{WRITE}$	Write to one EEPROM byte time	EECMD = 21h	4	16	30	
$t_{READ}$	Read one EEPROM byte time	EECMD = 22h		1.4		
$n_{CYCLE}$	Write cycle endurance <sup>(1)</sup>	$V_{DD} = 3.0$ V, $T_A = 25^\circ\text{C}$	10'000			cycles
		$V_{DD} = 5.5$ V, $T_A = 85^\circ\text{C}$	100			
$t_{RET}$	Data retention time <sup>(1)</sup>	$T_A = 55^\circ\text{C}$ (average)	10			years

<sup>(1)</sup> Not 100% tested.

### 6.2.1.TYPICAL CHARACTERISTICS

Typical characteristics for Direct Switching Mode (DSM), Level Switching Mode (LSM) and switchover disabled:  
For these diagrams, I<sup>2</sup>C-bus inactive, CLKOUT disabled.

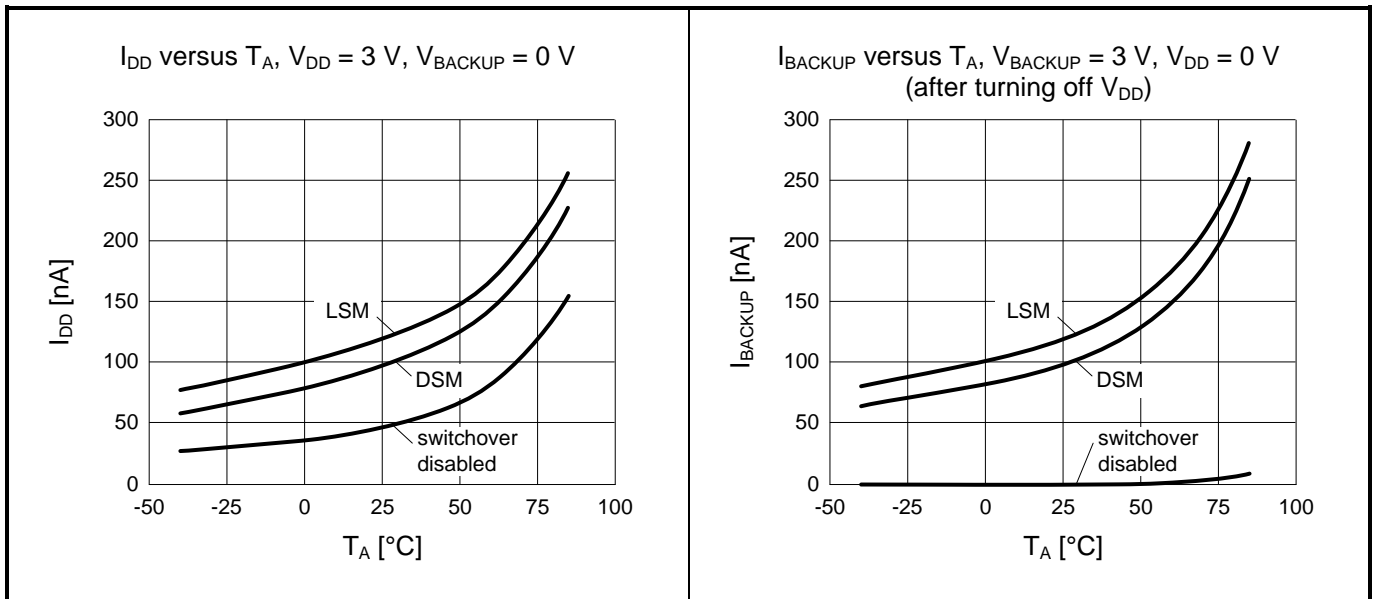
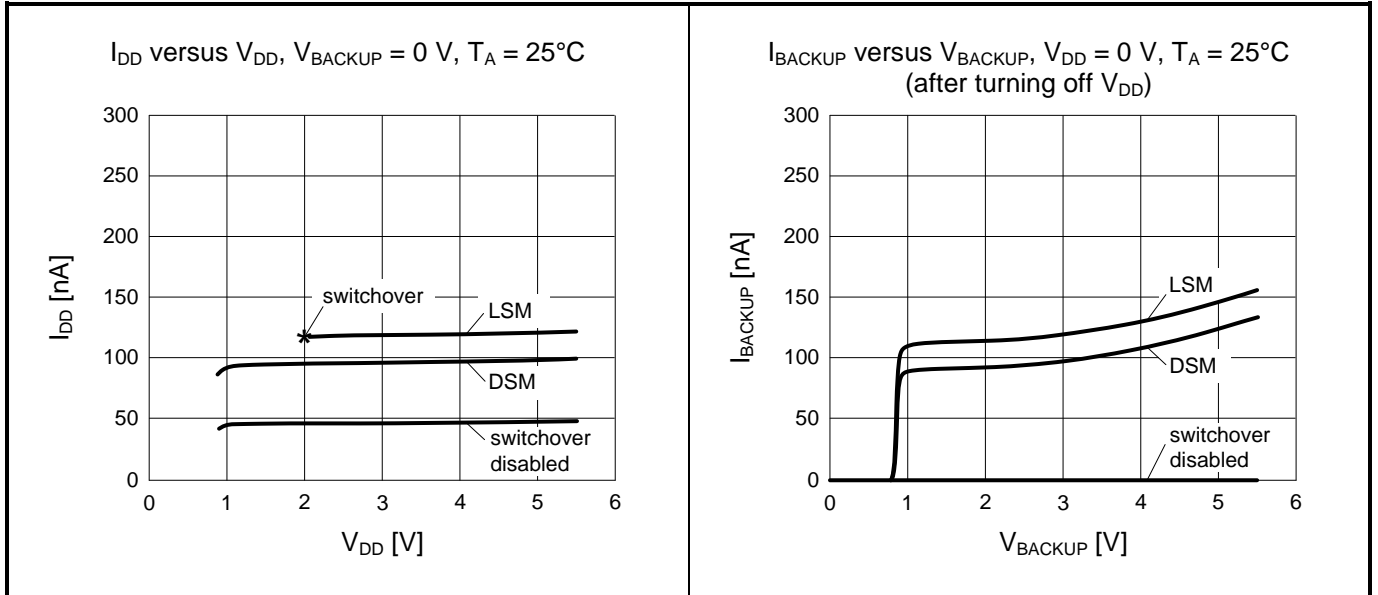

### 6.3. OSCILLATOR PARAMETERS

For this Table,  $T_A = -40$  to  $+85^\circ\text{C}$  unless otherwise indicated.  $V_{DD} = 1.2$  to  $5.5$  V, TYP values at  $25^\circ\text{C}$  and  $3.0$  V.

Oscillator Parameters:

SYMBOL	PARAMETER	CONDITIONS	MIN	TYP	MAX	UNIT
<b>Xtal General</b>						
F	Crystal Frequency			32.768		kHz
$t_{START}$	Oscillator start-up time at $V_{DD} = 3.0$ V	$T_A = 25^\circ\text{C}$		0.2	1 3	s
$V_{START}$	Oscillator start-up voltage		1.3			V
$\Delta f/V$	Frequency vs. voltage characteristics	$V_{DD} = 1.1$ V to $5.5$ V $T_A = 25^\circ\text{C}$		0.5	1	ppm/V
$V_{DDR}$	$V_{DD}$ rising slew rate	$V_{DD} = 1.1$ V to $3.6$ V $V_{DD} = 3.6$ V to $5.5$ V			2.5 3.8	V/ms
$V_{DDF}$	$V_{DD}$ falling slew rate	$V_{DD} = 5.5$ V to $1.1$ V			2.2	
$\delta_{CLKOUT}$	CLKOUT duty cycle	$V_{DD} = 1.1$ V to $5.5$ V $F_{CLKOUT} = 32.768$ kHz		50 $\pm$ 10		%
<b>Xtal Frequency Characteristics</b>						
$\Delta F/F$	Frequency accuracy	$T_A = 25^\circ\text{C}$		$\pm 5$		ppm
$\Delta F/F_{TOPR}$	Frequency vs. temperature characteristics	$T_{OPR} = -40$ to $+85^\circ\text{C}$ $V_{DD} = 3.0$ V	$-0.035^{ppm}/^\circ\text{C}^2 (T_{OPR}-T_0)^2 \pm 10\%$			ppm
$T_0$	Turnover temperature		$+25 \pm 5$			$^\circ\text{C}$
$\Delta F/F$	Aging first year max.	$T_A = 25^\circ\text{C}$ , $V_{DD} = 3.0$ V			$\pm 3$	ppm
<b>Xtal Frequency Offset Correction</b>						
$\Delta t/t$	EEOffset correction: Min. corr. step (LSB) and Max. corr. range	$T_A = -40$ to $+85^\circ\text{C}$	$\pm 0.954$		+243.2/ -244.1	ppm
$\Delta t/t$	EEOffset. Achievable time accuracy.	Calibrated at an initial temperature and voltage	-0.48		+0.48	ppm
$\Delta t/t$	EEOffset. Factory Calibrated time accuracy.	Calibrated at $T_A = 25^\circ\text{C}$ , $V_{DD} = 3.0$ V		$\pm 1$		ppm

#### 6.3.1.XTAL FREQUENCY VS. TEMPERATURE CHARACTERISTICS

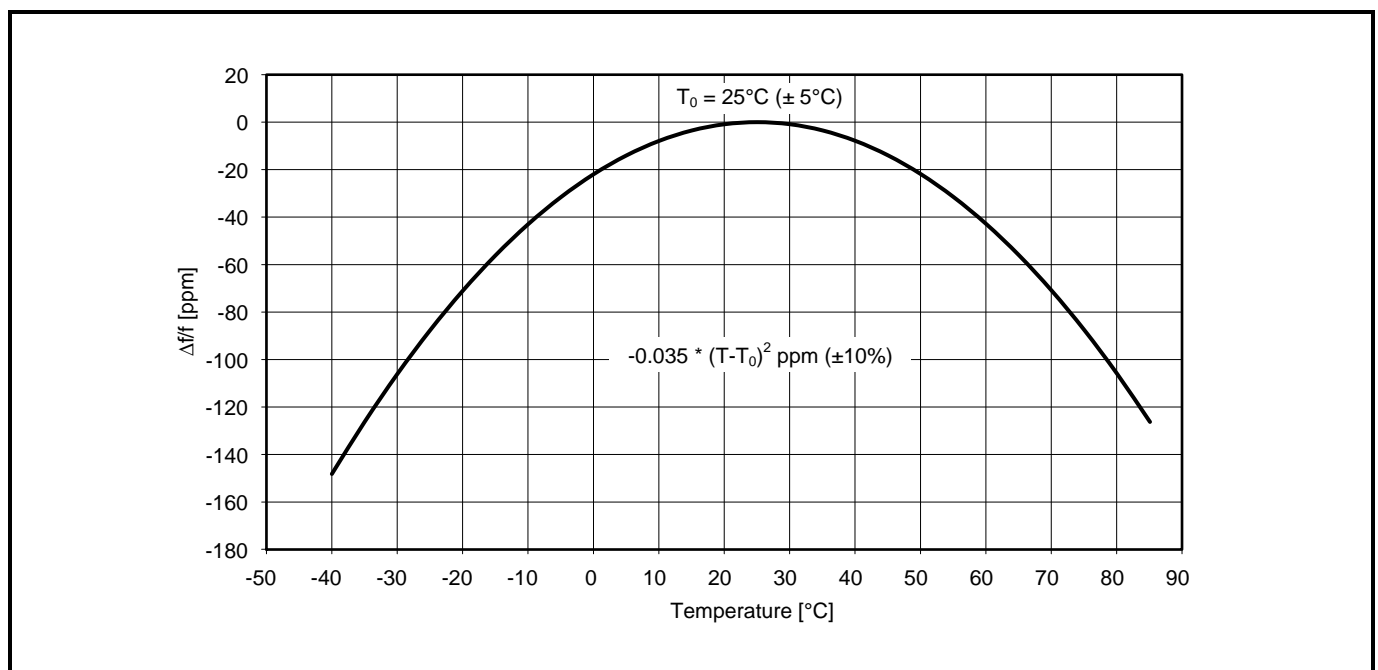

### 6.4. POWER ON AC ELECTRICAL CHARACTERISTICS

The following Figure describes the power on AC electrical characteristics for the CLKOUT pin. The clock output signal on CLKOUT pin is primarily controlled by the CLKOE bit and the FD field (EEPROM 35h). See also CLOCK OUTPUT SCHEME and USE OF THE CONFIGURATION REGISTERS.

Power On AC Electrical Characteristics:

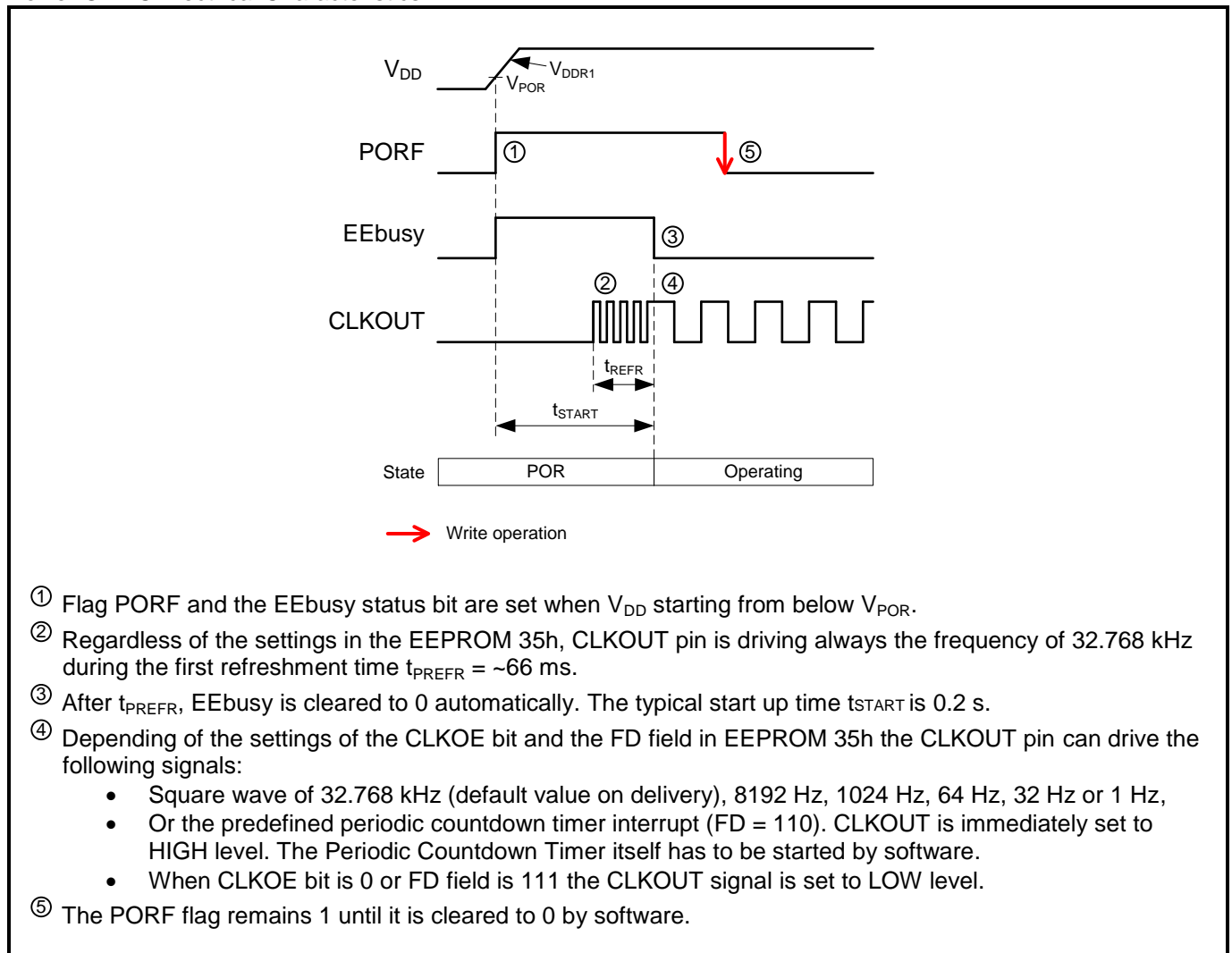

For this Table,  $T_A = -40$  to  $+85^\circ\text{C}$  and  $V_{DD} = 1.2$  to  $5.5$  V, TYP values at  $25^\circ\text{C}$  and  $3.0$  V.

Power On AC Electrical Parameters:

SYMBOL	PARAMETER	CONDITIONS	MIN	TYP	MAX	UNIT
$V_{DDR1}$	$V_{DD}$ rising slew rate at initial power on reset (POR)		0.1		1	V/ms
$t_{START}$	Oscillator start-up time at $V_{DD} = 3.0$ V	$T_A = 25^\circ\text{C}$		0.2	1	s
$V_{START}$	Oscillator start-up voltage		1.3		3	V
$t_{PREFR}$	First refreshment time			66		ms

### 6.5. I<sup>2</sup>C-BUS CHARACTERISTICS

The following Figure and Table describe the I<sup>2</sup>C AC electrical parameters.

I<sup>2</sup>C AC Parameter Definitions:

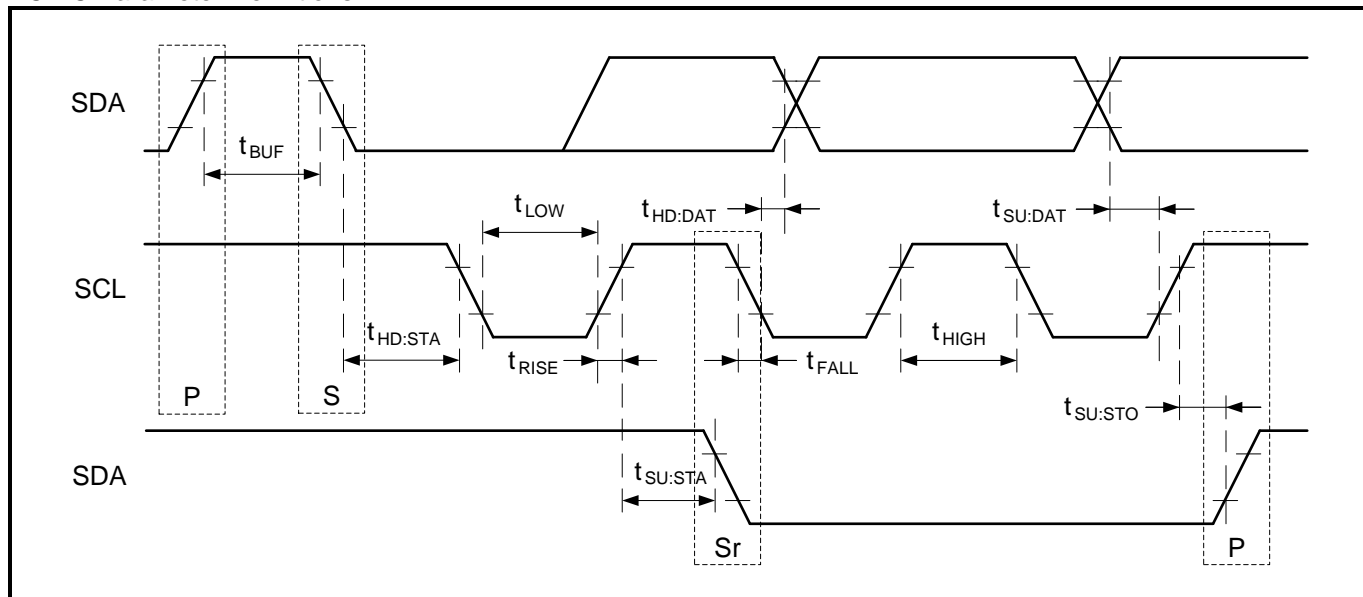

For the following Table, T<sub>A</sub> = -40 to +85°C.

I<sup>2</sup>C AC Electrical Parameters:

SYMBOL	PARAMETER	V <sub>DD</sub> ≥ 1.2 V		V <sub>DD</sub> ≥ 2.0 V		UNIT
		MIN	MAX	MIN	MAX	
f <sub>SCL</sub>	SCL input clock frequency	0	100	0	400	kHz
t <sub>LOW</sub>	Low period of SCL clock	4.7		1.3		μs
t <sub>HIGH</sub>	High period of SCL clock	4.0		0.6		μs
t <sub>RISE</sub>	Rise time of SDA and SCL		1000		300	ns
t <sub>FALL</sub>	Fall time of SDA and SCL		300		300	ns
t <sub>HD:STA</sub>	START condition hold time	4.0		0.6		μs
t <sub>SU:STA</sub>	START condition setup time	4.7		0.6		μs
t <sub>SU:DAT</sub>	SDA setup time	250		100		ns
t <sub>HD:DAT</sub>	SDA hold time	0		0		μs
t <sub>SU:STO</sub>	STOP condition setup time	4.0		0.6		μs
t <sub>BUF</sub>	Bus free time before a new transmission	4.7		1.3		μs

S = Start condition, Sr = Repeated Start condition, P = Stop condition

**Caution:**

When accessing the RV-3028-C7, all communication from transmitting the Start condition to transmitting the Stop condition after access should be completed within 950 ms.

If such communication requires 950 ms or longer, the I<sup>2</sup>C-bus interface is reset by the internal bus timeout function.

## 7. TYPICAL APPLICATION CIRCUIT

### 7.1. OPERATING RV-3028-C7 WITH BACKUP SUPPLY VOLTAGE

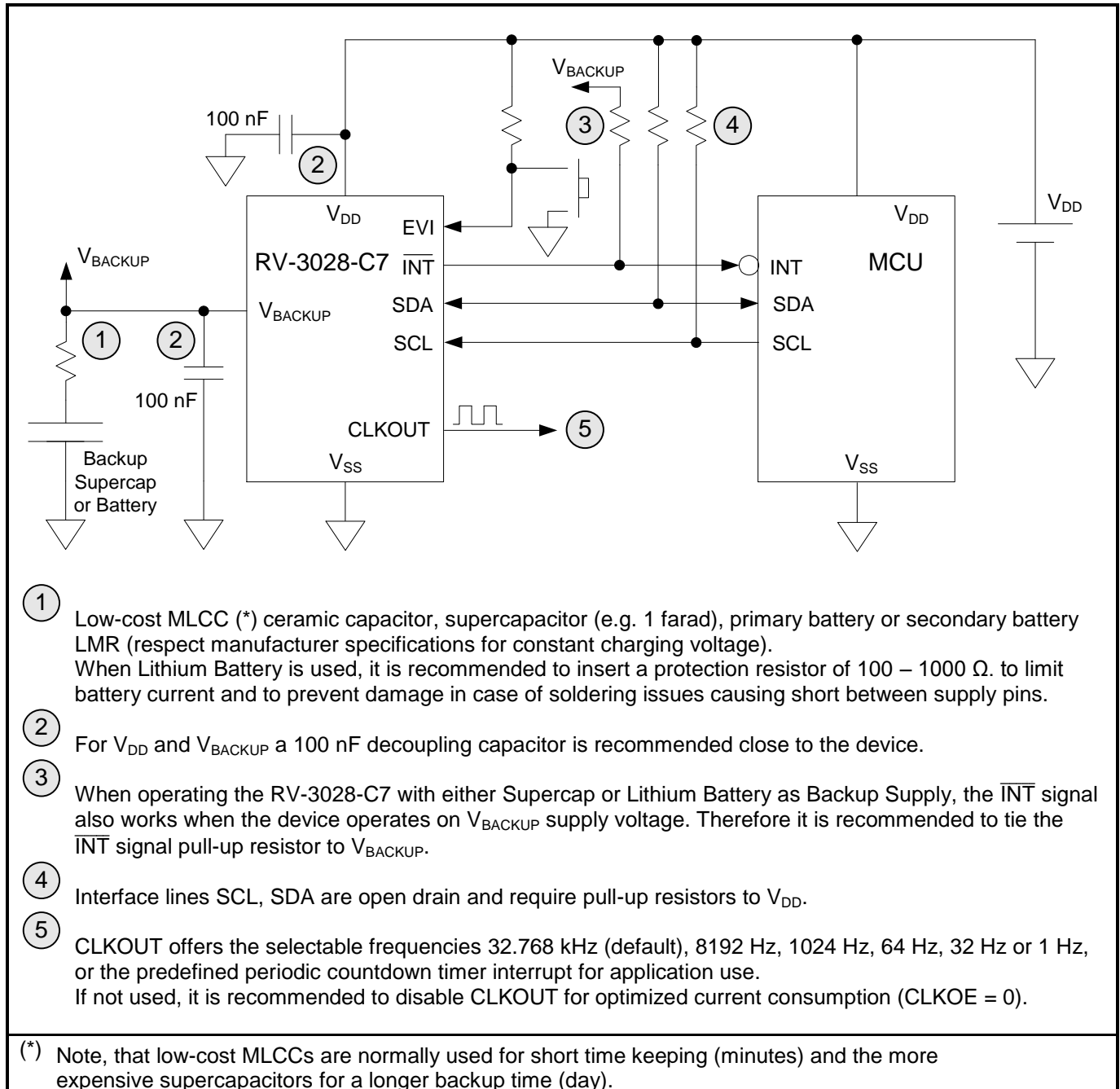

## 8. PACKAGE

### 8.1. DIMENSIONS AND SOLDER PAD LAYOUT

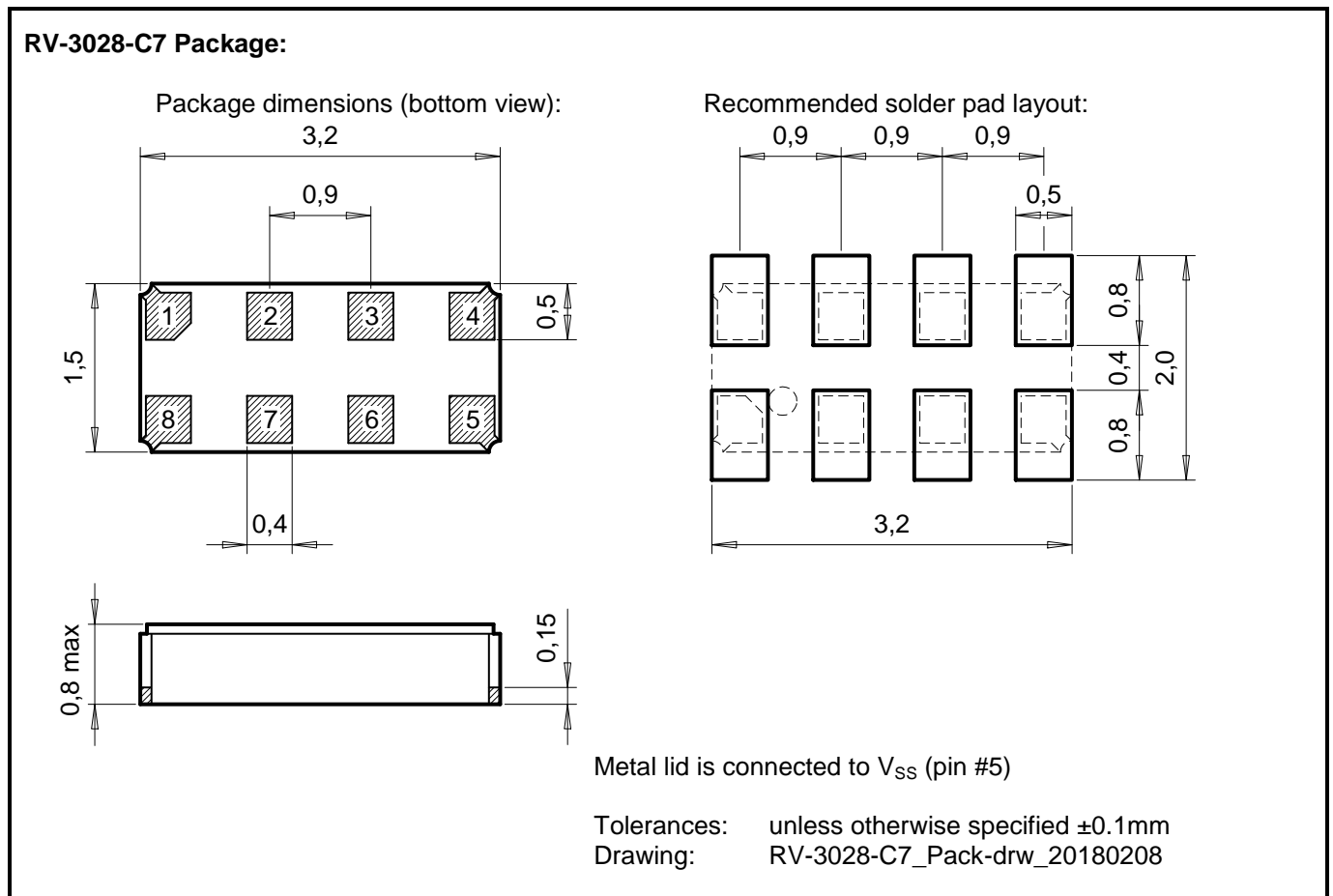

All dimensions in mm typical.

#### 8.1.1. RECOMMENDED THERMAL RELIEF

When connecting a pad to a copper plane, thermal relief is recommended.

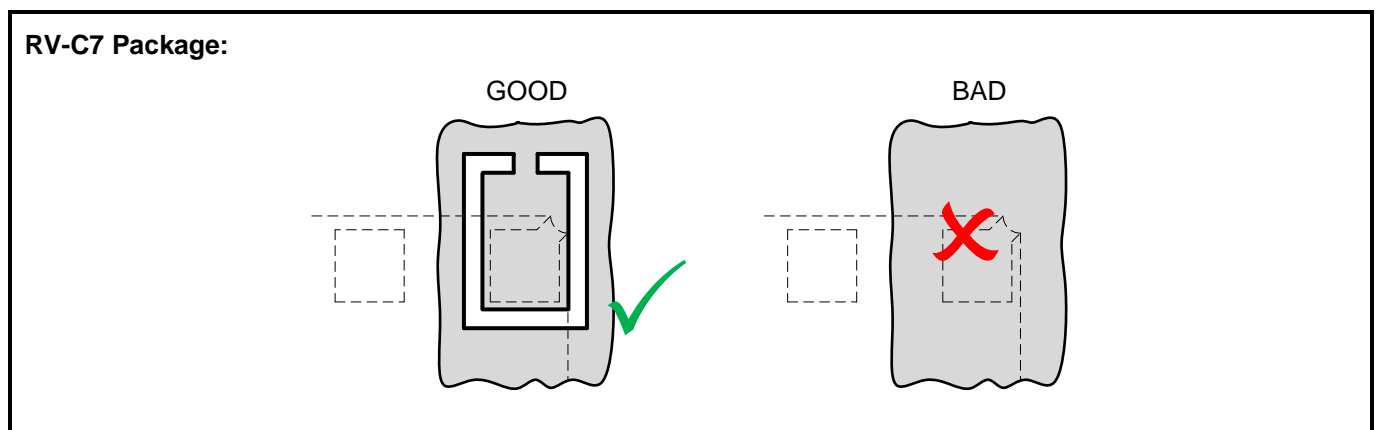



## 8.2. MARKING AND PIN #1 INDEX

Laser marking RV-3028-C7 Package: (top view)

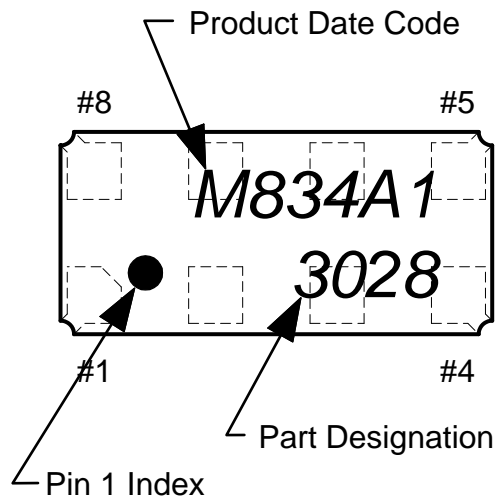

## 9. MATERIAL COMPOSITION DECLARATION & ENVIRONMENTAL INFORMATION

### 9.1. HOMOGENOUS MATERIAL COMPOSITION DECLARATION

Homogenous material information according to IPC-1752 standard

Material Composition RV-3028-C7:

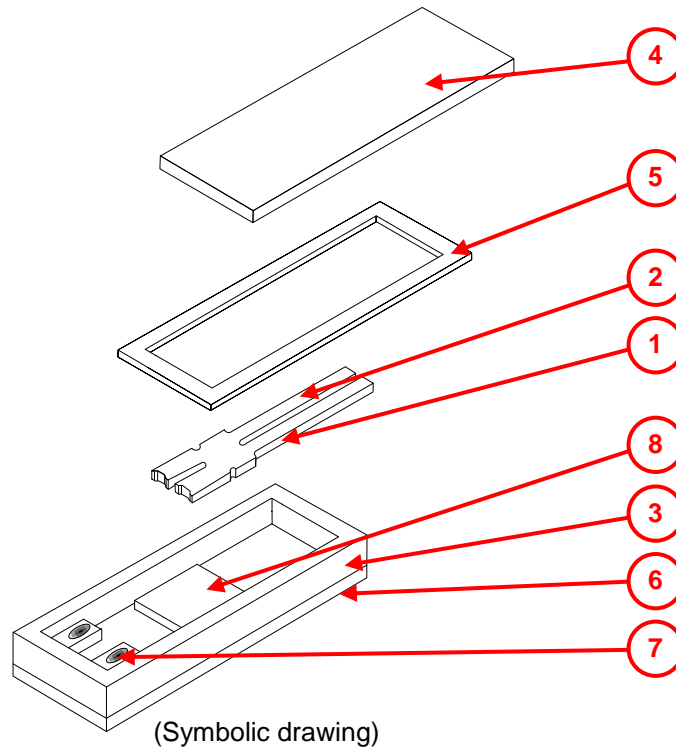

No.	Item Component Name	Sub Item Material Name	Material Weight		Substance Element	CAS Number	Comment
			(mg)	(%)			
1	Resonator	Quartz Crystal	0.13	100%	SiO <sub>2</sub>	14808-60-7	
2	Electrodes	Cr+Au	0.01	6%	Cr	Cr: 7440-47-3	
				94%	Au	Au: 7440-57-5	
3	Housing	Ceramic	6.90	100%	Al <sub>2</sub> O <sub>3</sub>	1344-28-1	
4	Metal Lid	Kovar Lid	2.67	95%	Fe53Ni29Co18	Fe: 7439-89-6 Ni: 7440-02-0 Co: 7440-48-4	Metal Lid (Kovar)
				4.95%	Ni	Ni: 7440-02-0	Nickel plating
				0.05%	Au	Au: 7440-57-5	Gold plating
5	Seal	Solder Preform	0.54	80%	Au80 / Sn20	Au: 7440-57-5	
				20%		Sn: 7440-31-5	
6	Terminations	Internal and external terminals	0.38	80%	Mo	Mo: 7439-98-7	Molybdenum
				15%	Ni	Ni: 7440-02-0	Nickel plating
				5%	Au 0.5 micron	Au: 7440-57-5	Gold plating
7	Conductive adhesive	Silver filled Silicone glue	0.09	88%	Ag	Ag: 7440-22-4	
				12%	Siloxanes and silicones	68083-19-2	di-Me, vinyl group-terminated
				0%	Distillates, petroleum hydrotreated	64742-47-8	Does not appear in finished product
8	CMOS IC	Silicon Gold bumps	0.64	90%	Si	Si: 7440-21-3	
				10%	Au	Au: 7440-57-5	
Unit weight			11.4				

**9.2. MATERIAL ANALYSIS & TEST RESULTS**

Homogenous material information according to IPC-1752 standard

No.	Item Component Name	Sub Item Material Name	RoHS						Halogen				Phthalates			
			Pb	Cd	Hg	Cr+6	PBB	PBDE	F	Cl	Br	I	BBP	DBP	DEHP	DINP
1	Resonator	Quartz Crystal	nd	nd	nd	nd	nd	nd	nd	nd	nd	nd	nd	nd	nd	nd
2	Electrodes	Cr+Au	nd	nd	nd	nd	nd	nd	nd	nd	nd	nd	nd	nd	nd	nd
3	Housing	Ceramic	nd	nd	nd	nd	nd	nd	nd	nd	nd	nd	nd	nd	nd	nd
4	Metal Lid	Kovar Lid & Plating	nd	nd	nd	nd	nd	nd	nd	nd	nd	nd	nd	nd	nd	nd
5	Seal	Solder Preform	nd	nd	nd	nd	nd	nd	nd	nd	nd	nd	nd	nd	nd	nd
6	Terminations	Int. & ext. terminals	nd	nd	nd	nd	nd	nd	nd	nd	nd	nd	nd	nd	nd	nd
7	Conductive adhesive	Silver filled Silicone glue	nd	nd	nd	nd	nd	nd	nd	nd	nd	nd	nd	nd	nd	nd
8	CMOS IC	Silicon & Gold bumps	nd	nd	nd	nd	nd	nd	nd	nd	nd	nd	nd	nd	nd	nd
	MDL	Measurement Detection Limit	2 ppm				5 ppm		50 ppm				0.003%		0.01%	

nd = not detectable

**Test methods:****RoHS**

Test method with reference to IEC 62321-5: 2013

MDL: 2 ppm (PBB / PBDE: 5 ppm)

**Halogen**

Test method with reference to BS EN 14582:2007

MDL: 50 ppm

**Phthalates**

Test method with reference to EN 14372

MDL: 0.003 % (DINP 0.01%)

**9.3. RECYCLING MATERIAL INFORMATION**

Recycling material information according to IPC-1752 standard.

Element weight is accumulated and referenced to the unit weight of 11.4 mg.

Item Material Name	No.	Item Component Name	Material Weight		Substance Element	CAS Number	Comment
			(mg)	(%)			
Quartz Crystal	1	Resonator	0.13	1.14	SiO <sub>2</sub>	14808-60-7	
Chromium	2	Electrodes	0.0006	0.005	Cr	Cr: 7440-47-3	
Ceramic	3	Housing	6.90	60.74	Al <sub>2</sub> O <sub>3</sub>	1344-28-1	
Gold	2 4 5 6 8	Electrodes Metal Lid Seal Terminations CMOS IC	0.53	4.63	Au	Au: 7440-57-5	
Tin	5	Seal	0.11	0.95	Sn	Sn: 7440-31-5	
Nickel	4 6	Metal Lid Terminations	0.19	1.67	Ni	Ni: 7440-02-0	
Molybdenum	6	Terminations	0.3	2.68	Mo	Mo: 7439-98-7	
Kovar	4	Metal Lid	2.53	22.33	Fe53Ni29Co18	Fe: 7439-89-6 Ni: 7440-02-0 Co: 7440-48-4	
Silver	7a	Conductive adhesive	0.079	0.7	Ag	Ag: 7440-22-4	
Siloxanes and silicones	7b	Conductive adhesive	0.011	0.10	Siloxanes and silicones	68083-19-2	di-Me, vinyl group-terminated
Distillates	7c	Conductive adhesive	0	0	Distillates	64742-47-8	hydrotreated petroleum, does not appear in finished products
Silicon	8	CMOS IC	0.58	5.07	Si	Si: 7440-21-3	
Unit weight (total)			11.4	100			

9.4. ENVIRONMENTAL PROPERTIES & ABSOLUTE MAXIMUM RATINGS

Package	Description
SON-8 ceramic package	Small Outline Non-leaded (SON), hermetically sealed ceramic package with metal lid

Parameter	Directive	Conditions	Value
Product weight (total)			11.4 mg
Storage temperature		Store as bare product	-55 to +125°C
Moisture sensitivity level (MSL)	IPC/JEDEC J-STD-020D		MSL1
FIT / MTBF			available on request

Terminal finish:

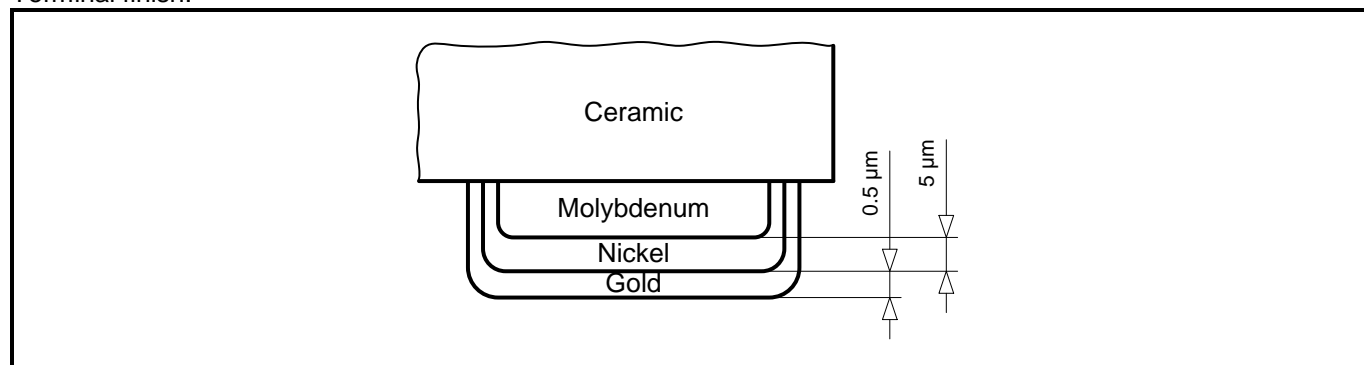

## 10. SOLDERING INFORMATION

Maximum Reflow Conditions in accordance with IPC/JEDEC J-STD-020C "Pb-free"

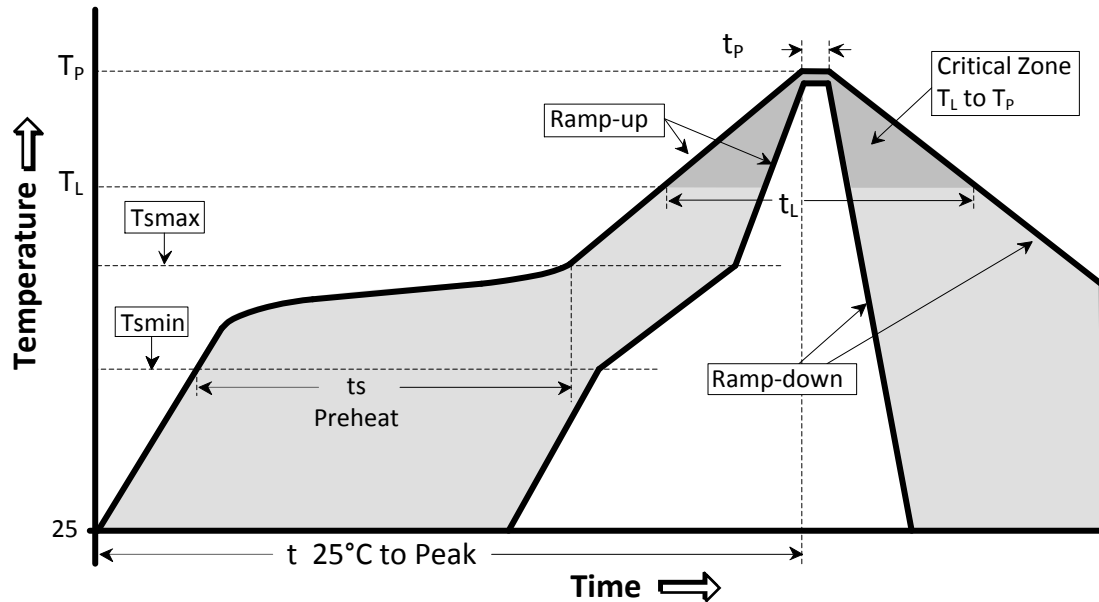

Temperature Profile	Symbol	Condition	Unit
Average ramp-up rate	$(T_{s_{max}} \text{ to } T_p)$	3°C / second max	°C / s
Ramp down Rate	$T_{cool}$	6°C / second max	°C / s
Time 25°C to Peak Temperature	$T_{to-peak}$	8 minutes max	min
<b>Preheat</b>			
Temperature min	$T_{s_{min}}$	150	°C
Temperature max	$T_{s_{max}}$	200	°C
Time $T_{s_{min}}$ to $T_{s_{max}}$	$t_s$	60 – 180	sec
<b>Soldering above liquidus</b>			
Temperature liquidus	$T_L$	217	°C
Time above liquidus	$t_L$	60 – 150	sec
<b>Peak temperature</b>			
Peak Temperature	$T_p$	260	°C
Time within 5°C of peak temperature	$t_p$	20 – 40	sec

## 11. HANDLING PRECAUTIONS FOR MODULES WITH EMBEDDED CRYSTALS

The built-in tuning-fork crystal consists of pure Silicon Dioxide in crystalline form. The cavity inside the package is evacuated and hermetically sealed in order for the crystal blank to function undisturbed from air molecules, humidity and other influences.

### Shock and vibration:

Keep the crystal / module from being exposed to **excessive mechanical shock and vibration**. Micro Crystal guarantees that the crystal / module will bear a mechanical shock of 5000 g / 0.3 ms.

The following special situations may generate either shock or vibration:

**Multiple PCB panels** - Usually at the end of the pick & place process the single PCBs are cut out with a router. These machines sometimes generate vibrations on the PCB that have a fundamental or harmonic frequency close to 32.768 kHz. This might cause breakage of crystal blanks due to resonance. Router speed should be adjusted to avoid resonant vibration.

**Ultrasonic cleaning** - Avoid cleaning processes using ultrasonic energy. These processes can damage crystals due to mechanical resonance of the crystal blank.

### Overheating, rework high temperature exposure:

Avoid overheating the package. The package is sealed with a seal ring consisting of 80% Gold and 20% Tin. The eutectic melting temperature of this alloy is at 280°C. Heating the seal ring up to >280°C will cause melting of the metal seal which then, due to the vacuum, is sucked into the cavity forming an air duct. This happens when using hot-air-gun set at temperatures >300°C.

Use the following methods for rework:

- Use a hot-air- gun set at 270°C.
- Use 2 temperature controlled soldering irons, set at 270°C, with special-tips to contact all solder-joints from both sides of the package at the same time, remove part with tweezers when pad solder is liquid.

## 12. PACKING & SHIPPING INFORMATION

Reel: 7" = 178 mm

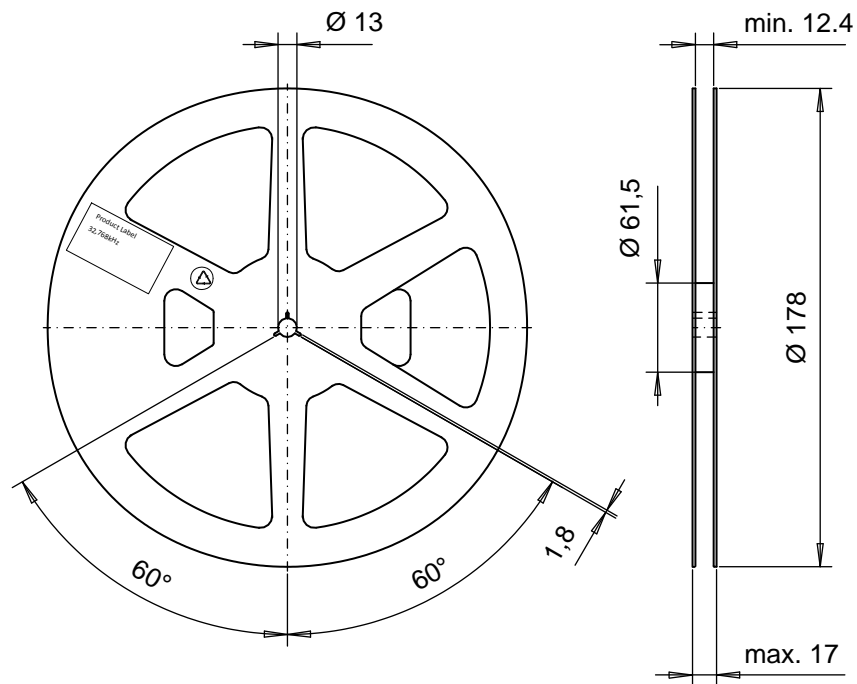

### Carrier Tape:

Material: Polycarbonate, conductive

Width: 12 mm

Tape Leader and Trailer: Minimum length 300 mm

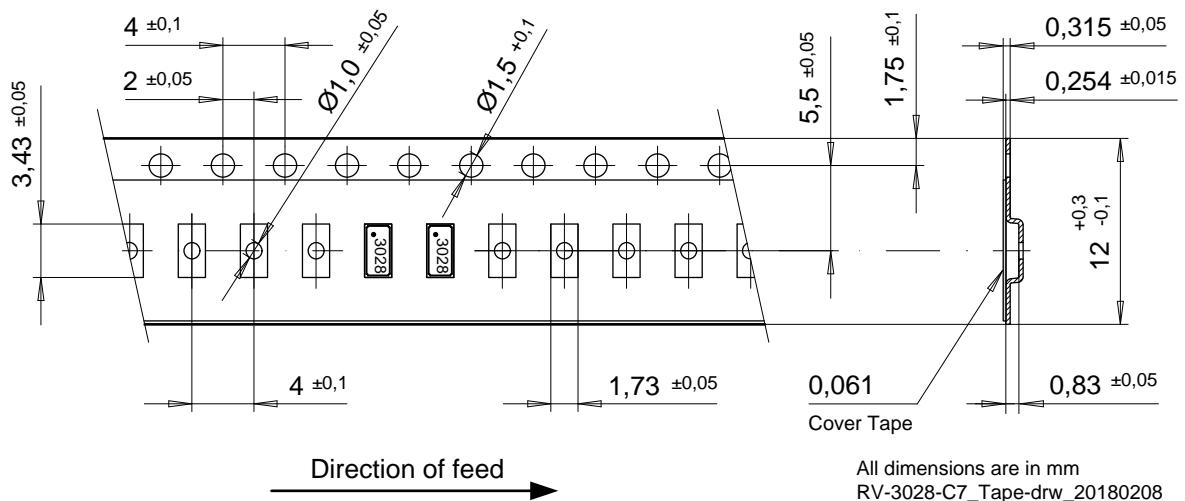

### Cover Tape:

Tape: Polypropylene, 3M™ Universal Cover Tape (UCT)

Adhesive Type: Pressure sensitive, Synthetic Polymer

Thickness: 0.061 mm

### Peel Method:

Medial section removal, both lateral stripes remain on carrier



### 13. COMPLIANCE INFORMATION

Micro Crystal confirms that the standard product Real-Time Clock Module RV-3028-C7 is compliant with “EU RoHS Directive” and “EU REACH Directives”.

Please find the actual Certificate of Conformance for Environmental Regulations on our website:

[CoC\\_Environment\\_RV-Series.pdf](#)

### 14. DOCUMENT REVISION HISTORY

Date	Revision #	Revision Details
February 2018	0.91	Preliminary
April 2018	0.92	Modified register 11h (GP Bits), 3.6. Corrected Trickle Charger resistor values, 3.14.5. and 4.3. Added Power On Reset Interrupt function, 3.14.4. and 4.15. Modified EEPROM registers 36h/37h (EEOffset, Switchover, Trickle), 3.14.5. Merged POR sections, 4.1. Divided Interrupt Scheme into two parts, 4.9.2. Corrected First Period duration, 4.10.3. Moved Switchover section, 4.14. Corrected Operating Parameters, 6.2. Updated Power On AC Electrical Characteristics, 6.4.
August 2018	1.0	First release Renamed Registers 11h, 35h, 36h and 37h, 2. ff. Added Register Conventions, 3.1. ff. Modified Register 11h GP Bits, 3.7. Modified Register 35h EEPROM Clkout with PORIE bit, 3.15.4. Modified Register 36h EEPROM Offset with EEOffset [8:1], 3.15.5. Modified Register 37h EEPROM Backup with EEOffset [0], BSIE, TCE, FEDE BSM and TCR, 3.15.6. Added Setting The Time, 4.5.1. and Reading The Time, 4.5.2. Corrected EEPROM Read/Write, 4.6. Added EEBusy Bit, 4.6.7. Corrected EEPROM Read/Write Conditions, 4.6.8. Added Use Of The Configuration EEPROM With RAM Mirror Registers, 4.7. Corrected Interrupt Scheme, 4.8.2. Corrected Periodic Countdown Timer Interrupt Function, 4.9. Corrected Time Stamp Function, 4.15. Added EEOffset Value Determination, 4.16.1. Added Verification Of The Corrected Time Accuracy, 4.16.2. Added User Programmable Password, 4.19. Added typical characteristics diagram for Level Switching Mode, 6.2. Updated Operating Parameters, 6.2. Updated Oscillator Parameters, 6.3.
August 2019	1.1	Corrected EEOffset default value, 1., 3.15.5., 3.15.6., 3.18., 4.15. and 6.3. Corrected Device Protection Diagram, 2.4. Corrected convention for EEPW registers to *WP, 3.1., 3.2., 3.15.3. and 4.18.1. Changed description and reset values for RESERVED RAM, 3.2. and 3.18. Changed Manufacturer EEPROM to Reserved EEPROM, 3.2., 3.17. and 3.18. Renamed Registers 25h, 26h and 27h, 3.2., 3.13., 3.18. and 4.13.2. Added Hours values for 24 hour mode and 12 hour mode, 3.3. Complemented 12_24 Bit function, 3.3., 3.5. and 3.7. Complemented Reset Bit function, 3.3., 3.7., 3.15.4., 4.1.1., 4.5. and 4.17. Complemented behavior of 0Dh – Timer Status 1 shadow register, 3.6. Renamed section 3.7. to Status And Control Registers, 3.7. Corrected External Event Interrupt function, 3.7., 3.8., 3.18., 4.7.2., 4.11. and 4.14. Corrected UF flag behavior at POR, 3.7., 3.18., and 4.9.1. Corrected Periodic Countdown Timer Interrupt function, 3.7., 4.7.2. and 4.8. Corrected Time Stamp function, 3.8., 4.4.5., 4.7.2. and 4.14. Complemented with RAM mirror, 3.12. and 3.15. Updated 27h – EE Command register description, 3.13. Complemented Register 2Bh – EEPROM Reserved, 3.15.1. and 3.18. Corrected Trickle Charger resistor values, 3.15.6., 3.18., 4.3. and 6.2. Complemented Automatic Backup Switchover Interrupt Function, 4.2. and 4.12. Complemented Setting and Reading the Time, 4.5. Changed order of chapters, 4.6. Complemented read and write EEPROM flowcharts, 4.6.7. Complemented EEBusy Bit function, 4.6.7. and 6.2. Created new section Use Of The Configuration Registers, 4.6.9. Corrected Periodic Time Update Interrupt function, 4.7.2. and 4.9. Corrected t <sub>START</sub> from 0.5 s to 0.2 s, 4.13.1., 6.3. and 6.4.

		<p>Corrected EEOffset compensation period, 4.15.          Complemented Setting and Reading the UNIX Time, 4.16.          Corrected User Programmable Password, 4.18.          Added hint for EEPW = 00000000h, 4.18.2.          Complemented Operating Parameters, 6.2.          Complemented EEPROM Characteristics, 6.2.          Added Typical Characteristics, 6.2.1.          Updated Power On AC Electrical Characteristics, 6.4.          Modified I<sup>2</sup>C AC Electrical Parameters table, 6.5.</p>
--	--	---

Information furnished is believed to be accurate and reliable. However, Micro Crystal assumes no responsibility for the consequences of use of such information nor for any infringement of patents or other rights of third parties which may result from its use. In accordance with our policy of continuous development and improvement, Micro Crystal reserves the right to modify specifications mentioned in this publication without prior notice. This product is not authorized for use as critical component in life support devices or systems.



Micro Crystal AG  
 Muehlestrasse 14  
 CH-2540 Grenchen  
 Switzerland

Phone +41 32 655 82 82  
 Fax +41 32 655 82 83  
 sales@microcrystal.com  
 www.microcrystal.com