

# SAPPHIRE PRO

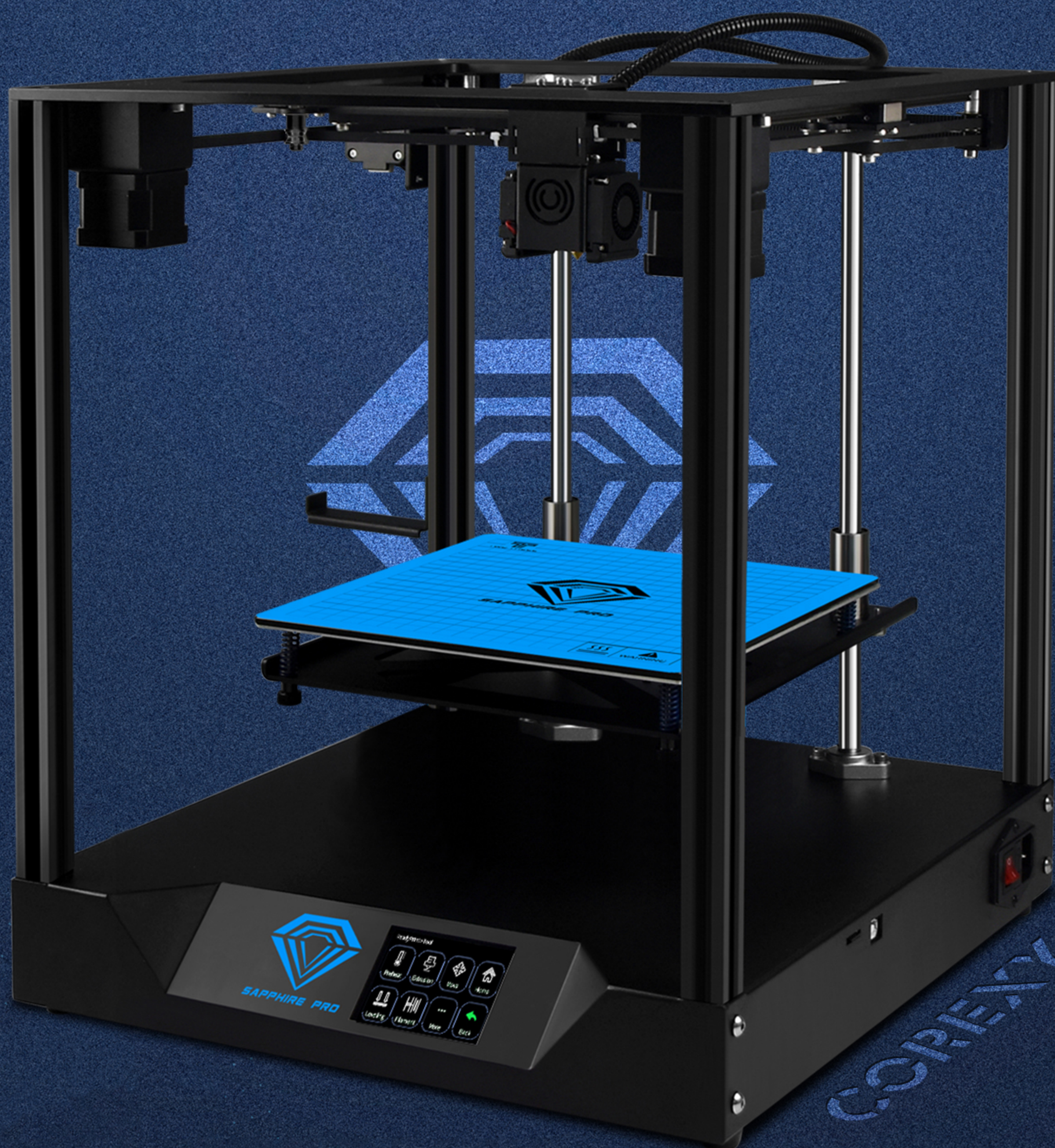

Shenzhen Two Trees Technology Co., Ltd.



# SAPPHIRE PRO INSTALLION MANUAL

- 1、 Please ensure that the packaging is complete before receiving the goods.
- 2、 After unpacking, please check the parts list and accessories carefully.
- 3、 If you find any problems please contact your 3D printer provider in time
- 4、 The installation instructions in this graphic are model diagrams and are for reference only. The actual product is subject to receipt.
- 5、 **The F card contains installation software and other videos.**

1. When the machine is in operation, no flammable and explosive items can be placed beside the machine.
2. The machine is a moving part. After using the machine, the customer needs to check whether the key parts of the machine such as the heating pipe screws are loose.

## SAPPHIRE PRO INSTRUCTIONS FOR SAFE USE



- 1、 During use, please note that the key parts of the printer such as the hot bed and extrusion head are working. The high temperature generated by the heat during the process to avoid burns!



- 2、 The printer with 220VAC / 110VAC and other high-voltage power interfaces. Please operate with care. Avoid electric shock!



- 3、 The key components of the printer (such as hot bed, extrusion head, etc.) have relatively high power. During the process, please ensure that the terminals are firmly connected to avoid sparks due to loose wiring. Cause a fire. To ensure safety, please avoid unattended operation of the printer for a long time!



- 4、 The printer is a kind of mechanical equipment. Please keep away from moving parts during machine operation. Free from mechanical injuries!



- 5、 Please regularly lubricate and maintain the guide rails!



# TABLE OF CONTENTS

Installation and safety instructions	01
Catalog	02
Parts list	03
3D Printer Installation steps	04
Motherboard installation method	08
Service Information	09
FAQ	10



# PARTS LIST

No.	Name	Picture	QTY	No.	Name	Picture	QTY
A-1	Machine Bottom		1	C-1	Extrusion Head Kit		1
A-2	2020 profile		4	C-1-1	Bellows		1
A-2-1	M5*16		9	C-2	BMG Extruder Bag		1
A-2-2	M5*10		9	C-3	Teflon Tube		1
A-3	Lead screw		1	C-4	Rack Package		1
A-4	Belt		1	C-5	Machine Roof		1
A-5	Z-axis limit switch package		1	D-1	Rubber foot bag		1
A-6	Optical axis		2	D-2	Bottom seal		1
B-1	Hot bed		1	D-3	Material cutout test kit		1
B-2	Hot Bed Leveling Screw Bag		1	E-1	AC Power Cable		1
B-3	Hot bed support		1	E-2	Tool Bag <small>(Contains TF card with information files)</small>		1
B-4	Horizontal linear bearings		2	E-3	Filament <small>(Random Color)</small>		1
B-5	Insulation cotton		1	E-4	2020 profile seal pvc		3
B-6	Hot Bed Film		1	E-5	Grease		1



## 1. How to install "aluminum profile, light shaft" and "lead screw shaft"

No.	Name	QTY	Remark
A-1	Machine Bottom	1	
A-2	2020 profile	4	
A-2-1	M5*16	9	

No.	Name	QTY	Remark
A-2-2	M5*10	4	
A-3	Lead screw	1	
A-6	Optical axis	2	

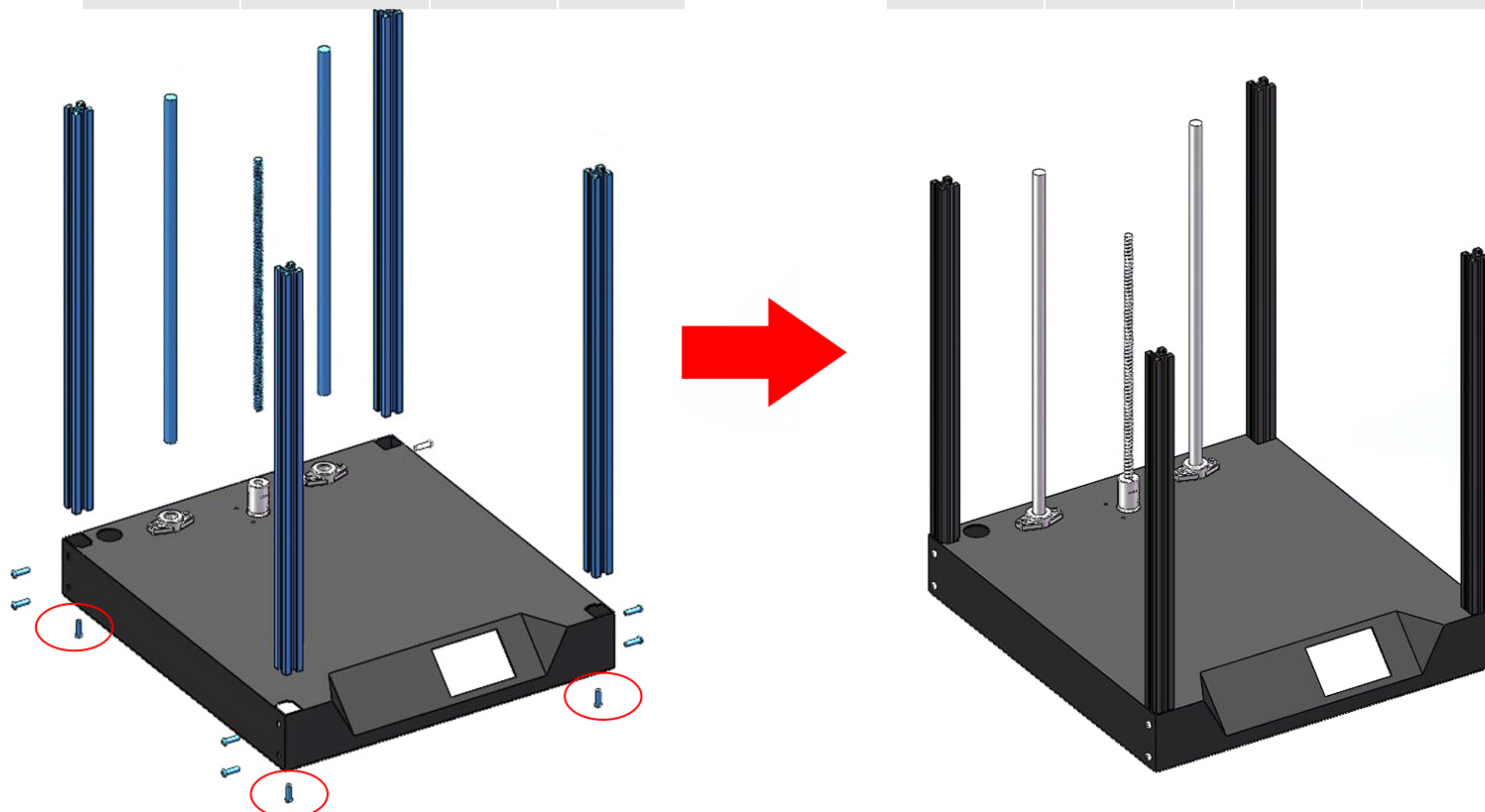

**⚠** Please fix the bottom A-2-2 screws first, and then the side A-2-1 screws.  
Be sure to install it correctly to ensure that the machine connection is secure.

## 2. How to assemble the hot-bed platform support

No.	Name	QTY	Remark
B-1	Hot bed	1	
B-2	Hot Bed Leveling Screw Bag	1	
B-3	Hot bed support	1	
B-4	Horizontal linear bearings	2	
B-5	Insulation cotton	1	

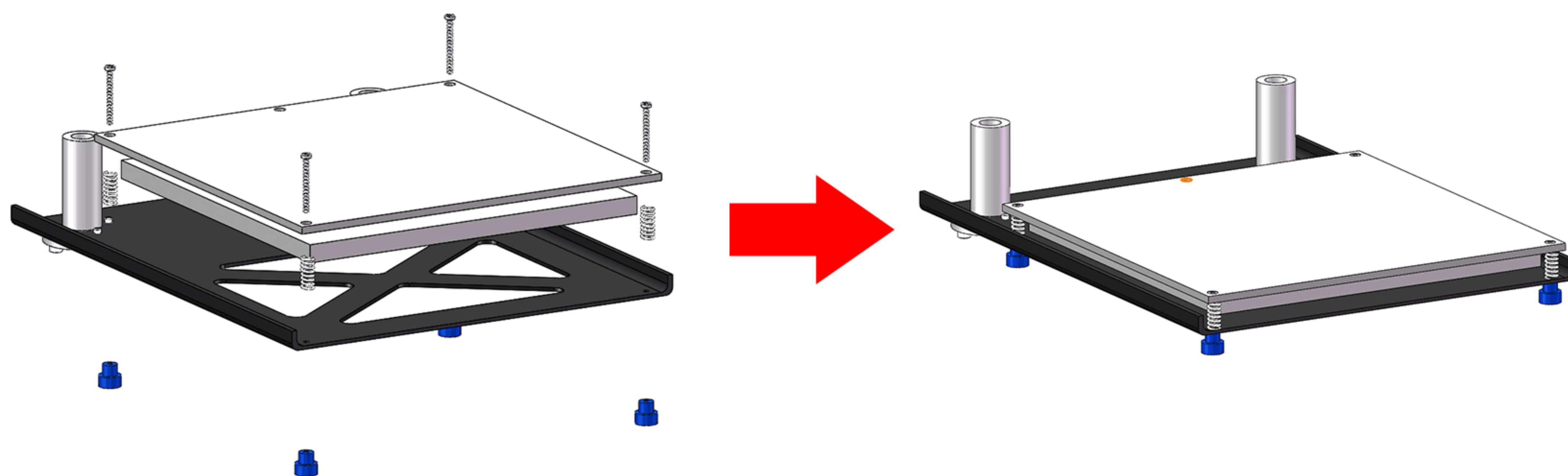



### 3. How to install the hot bed platform bracket

No.	Name	QTY	Remark
B-3	Hot Bed support	1	
A-5	Z-axis limit switch package	1	
B-6	Hot Bed Film	1	

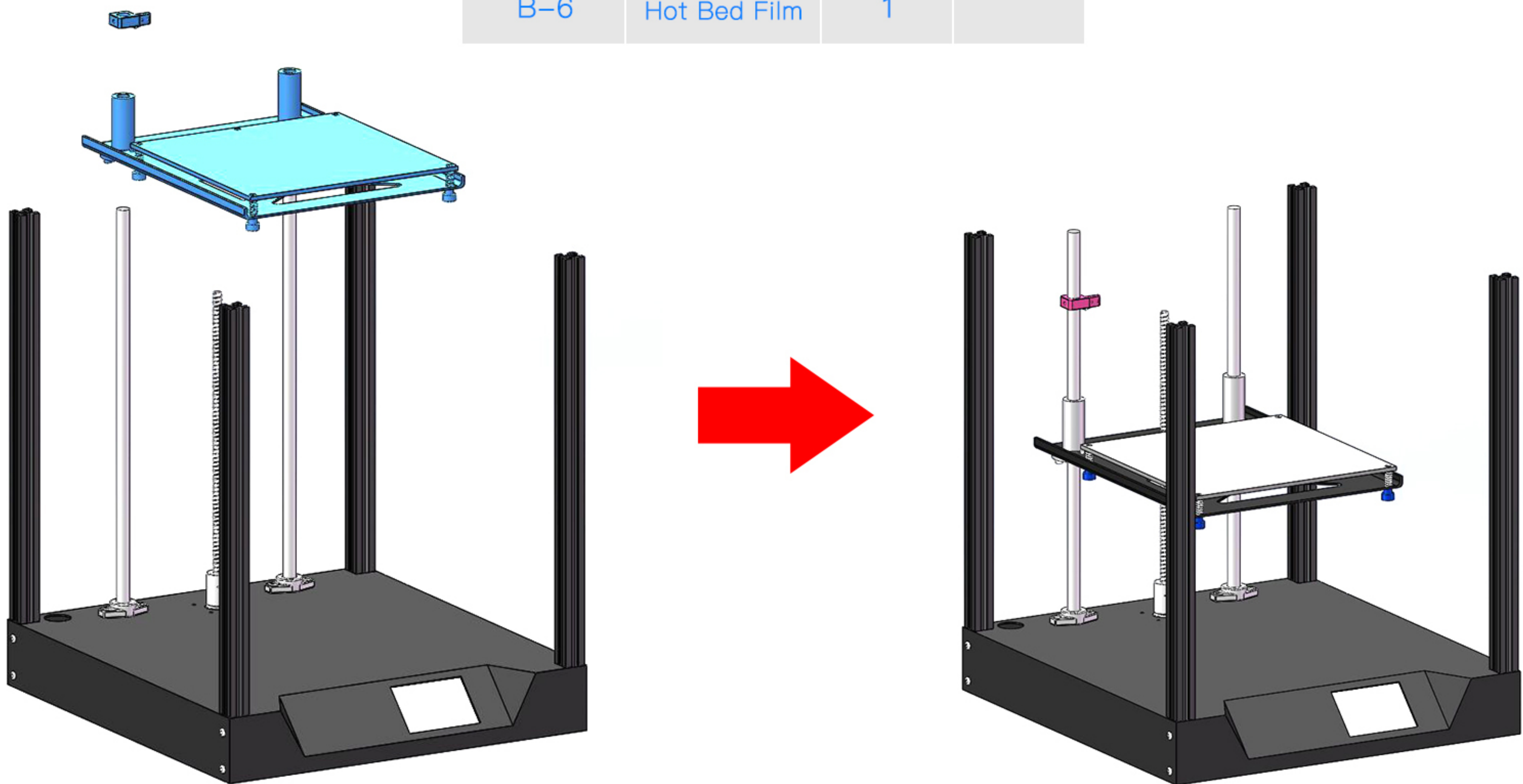

 When installing the hot bed, make sure that the hot bed support is on the same plane.

### 4. How to install the top

No.	Name	QTY	Remark
A-2-2	M5*10	4	
C-5	Machine Roof	1	

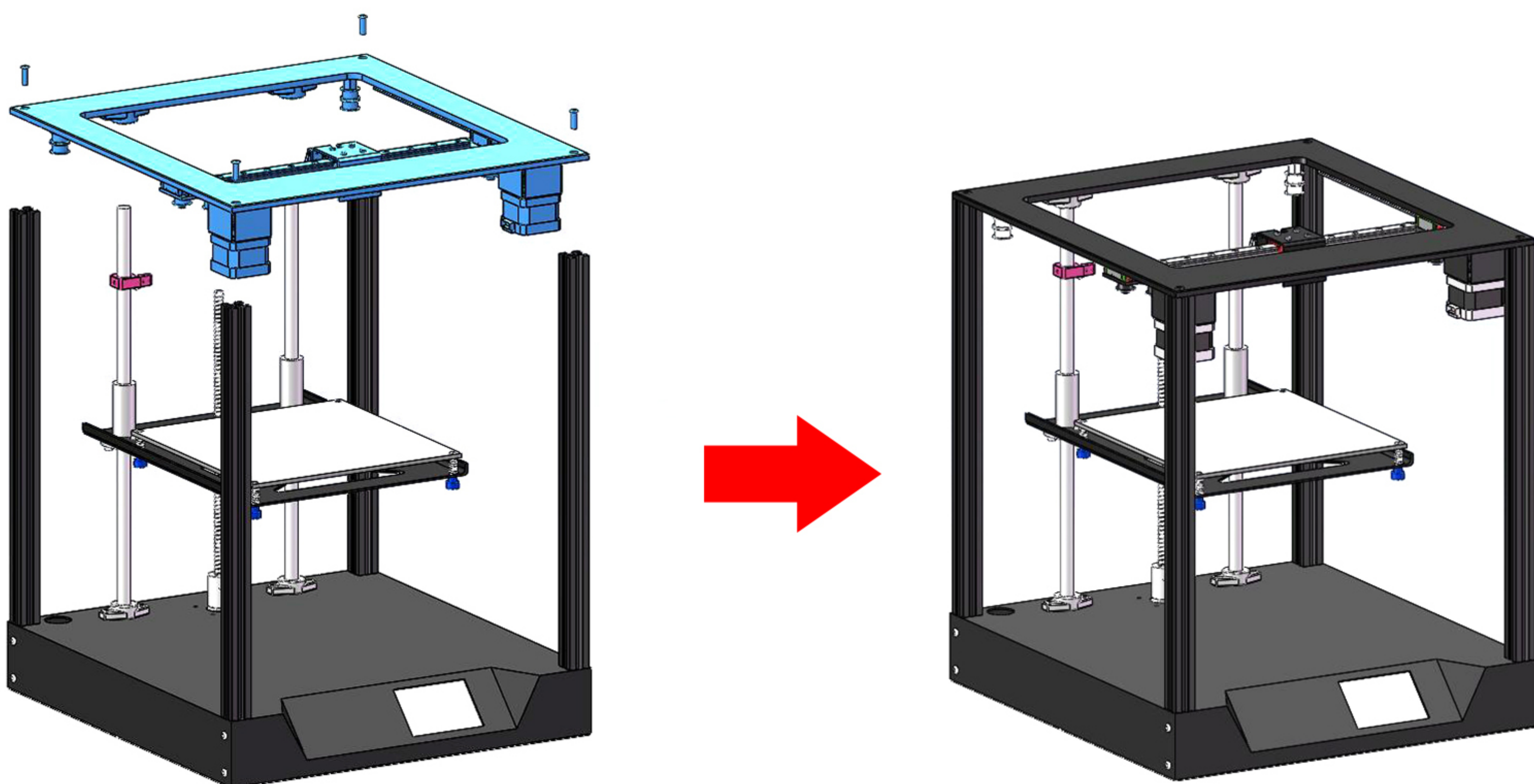

 When installing the top frame, ensure that the four profiles are on the same plane.



## 5. How to install various parts

No.	Name	QTY	Remark
C-1	Extrusion Head Kit	1	
C-2	BMG Extruder bag	1	
C-4	Rack package	1	

Extruder Kit

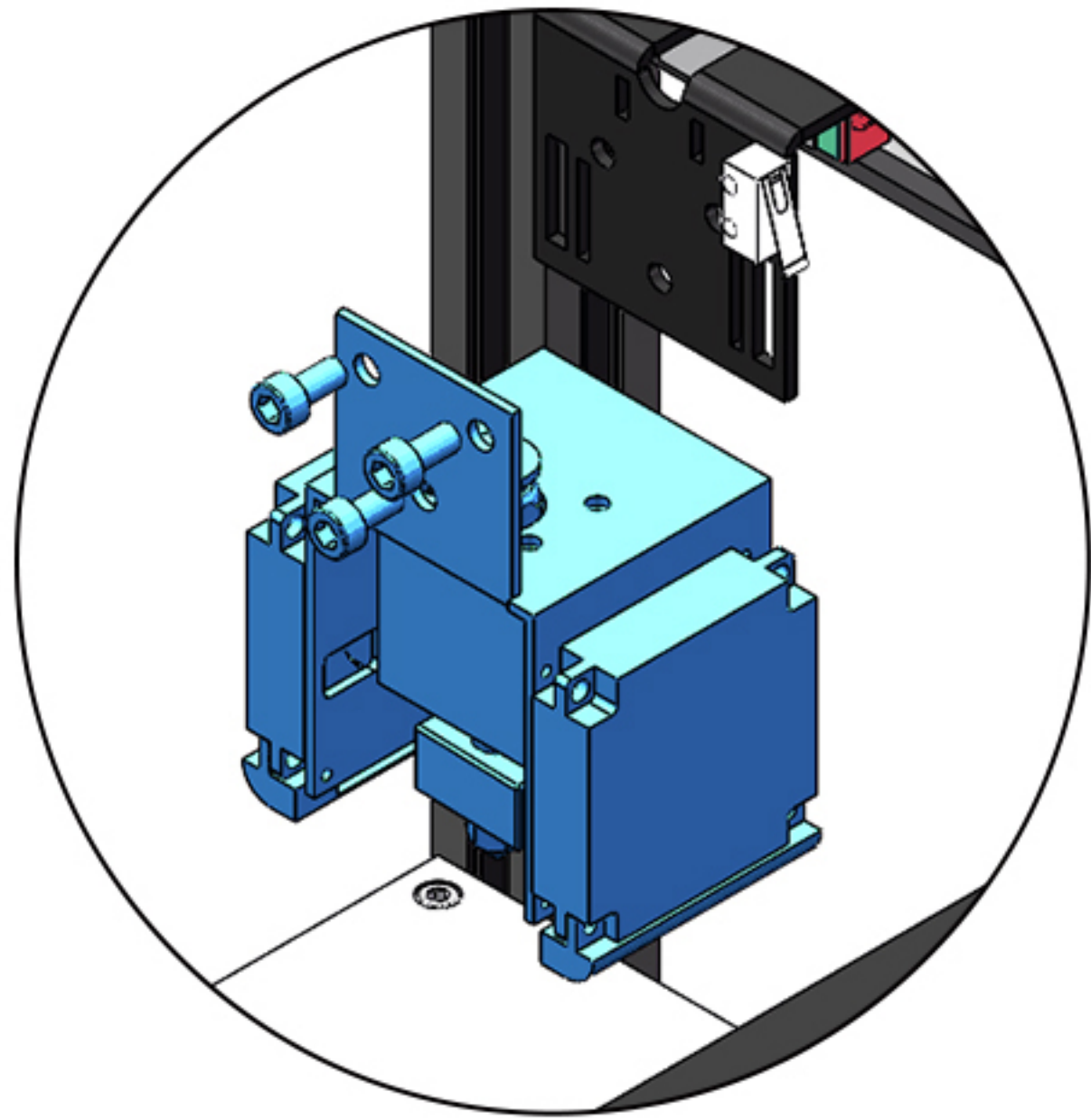

BMG Extruder

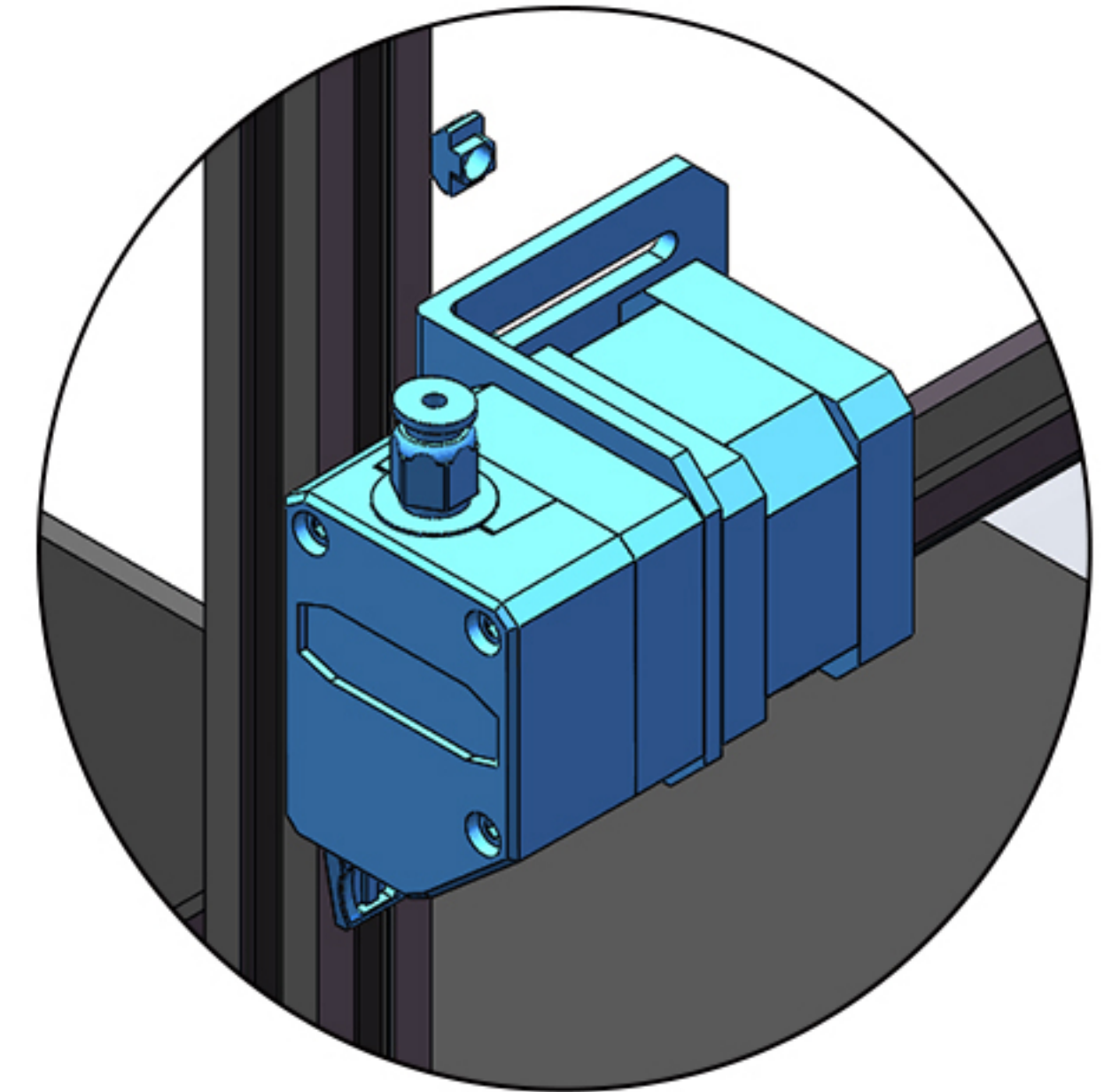

Rack package

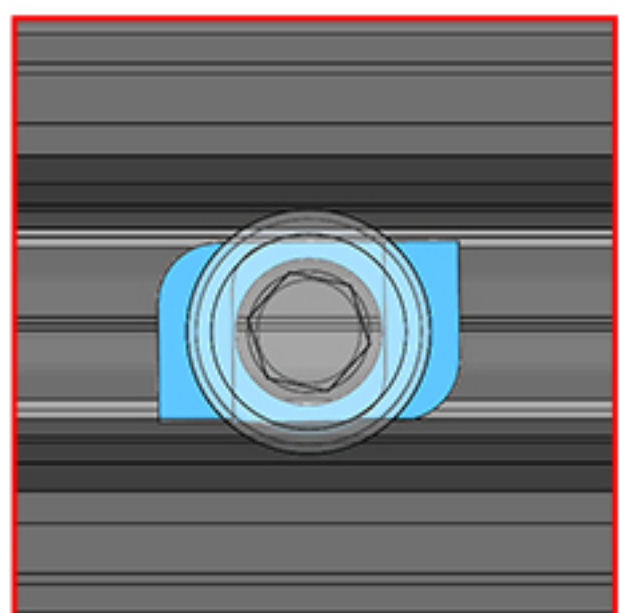
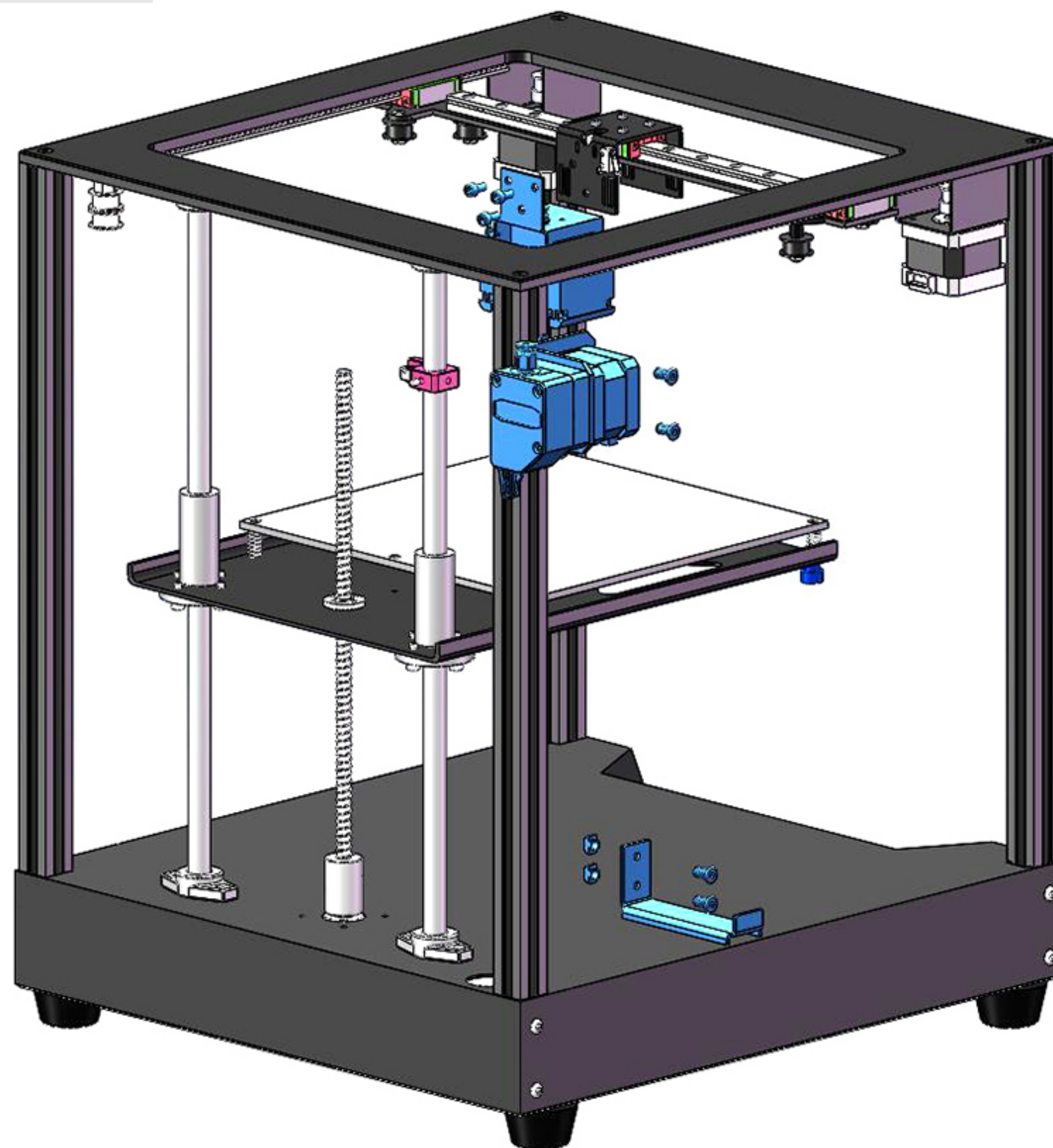
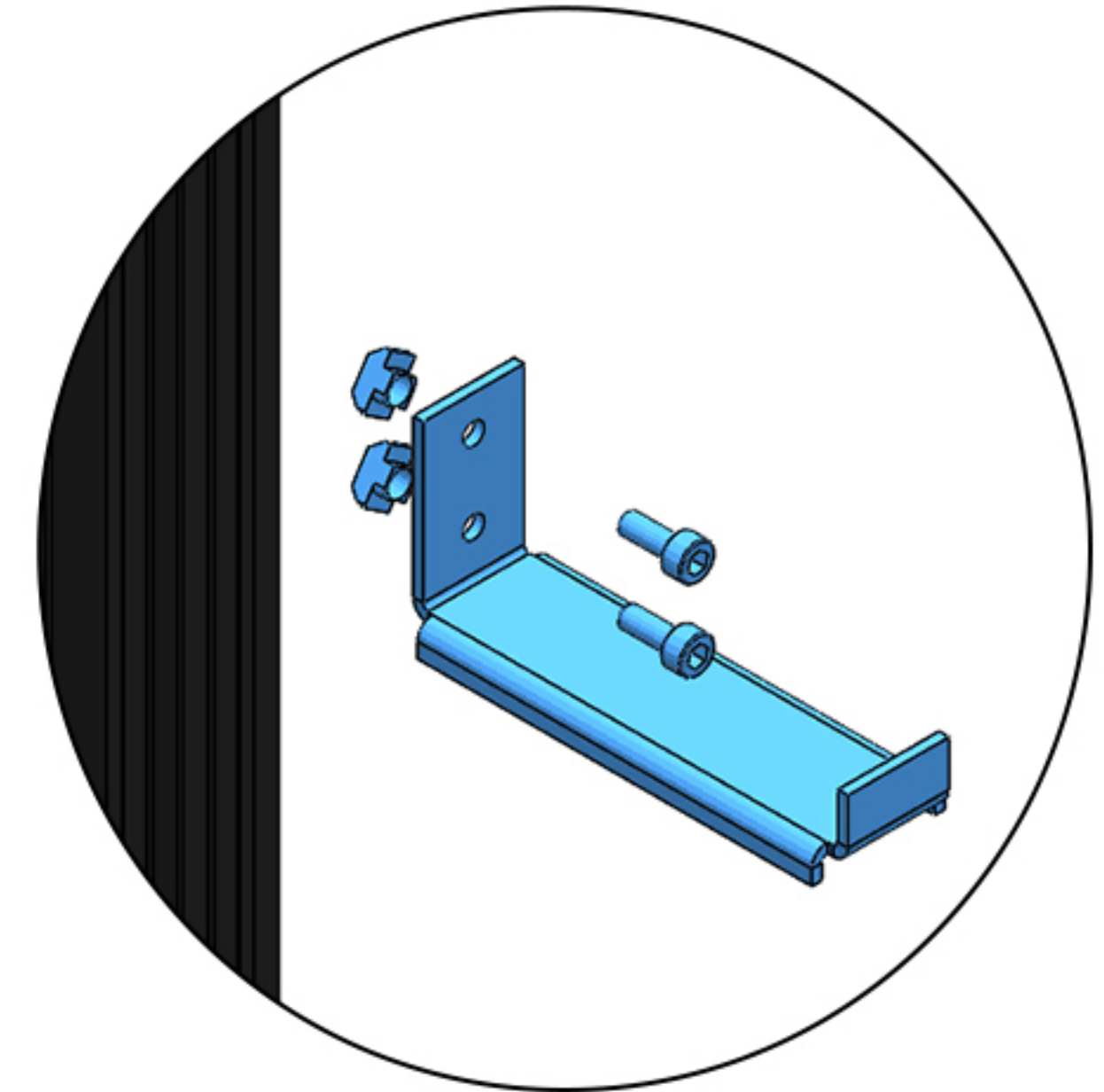

Please turn the screw clockwise first  
Drive T nut and fix

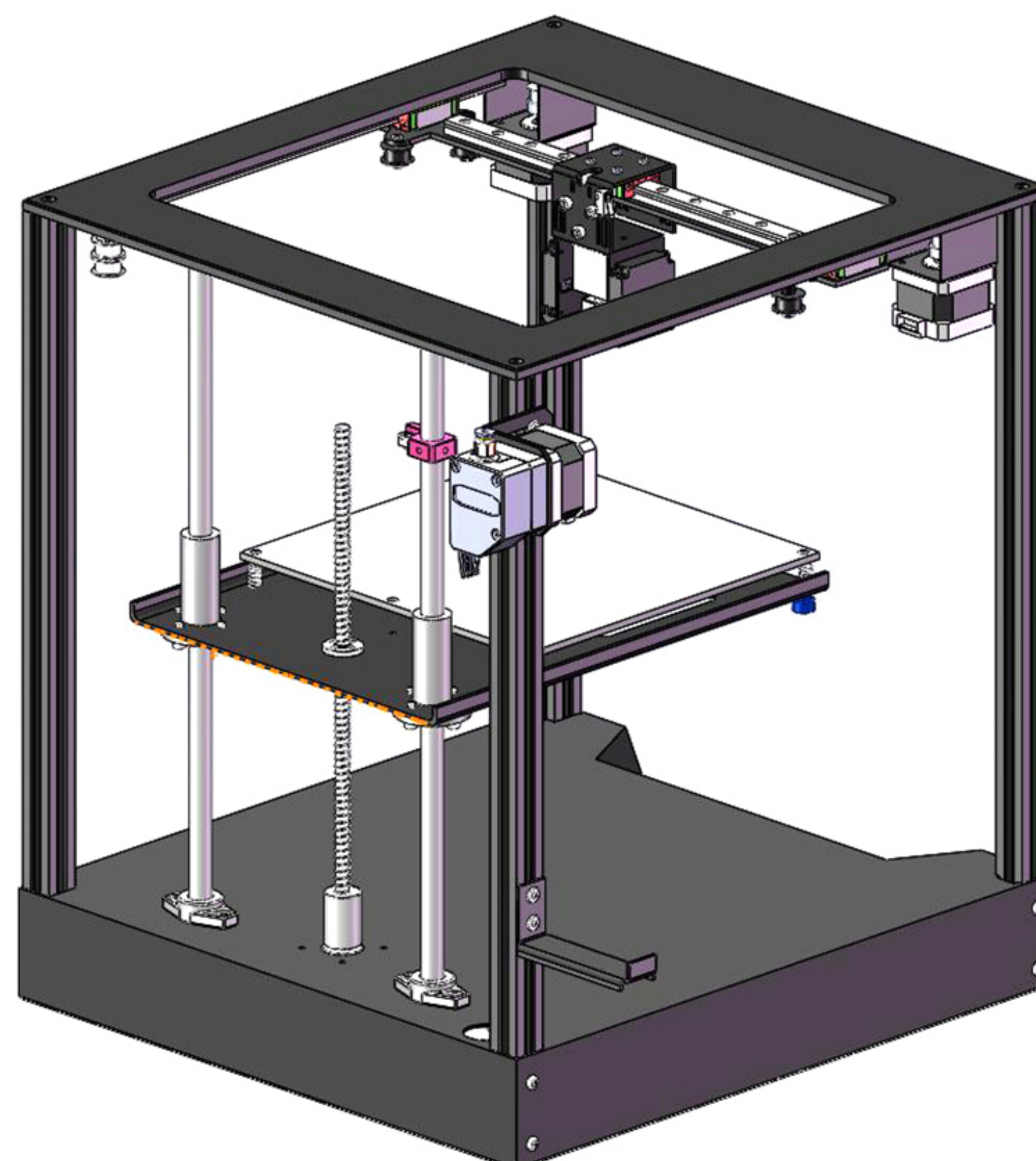

 Please make sure all parts are installed correctly.



## 6. How to install the bottom seal & each wiring part

No.	Name	QTY	Remark
D-1	Rubber foot bag	1	4pcs
D-2	Bottom seal	1	

- 1. Hot bed line group
- 2. Extrusion head line group

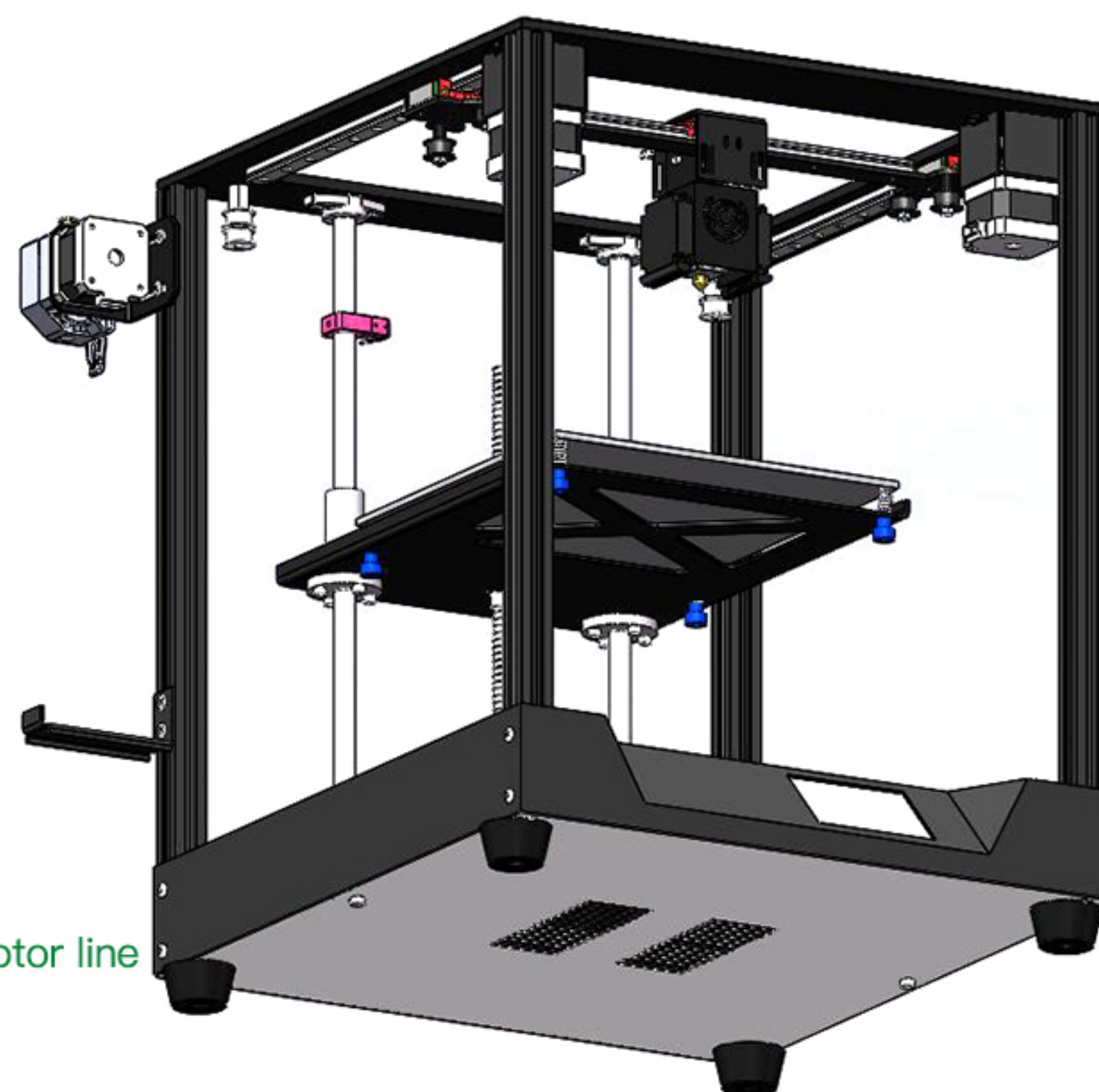
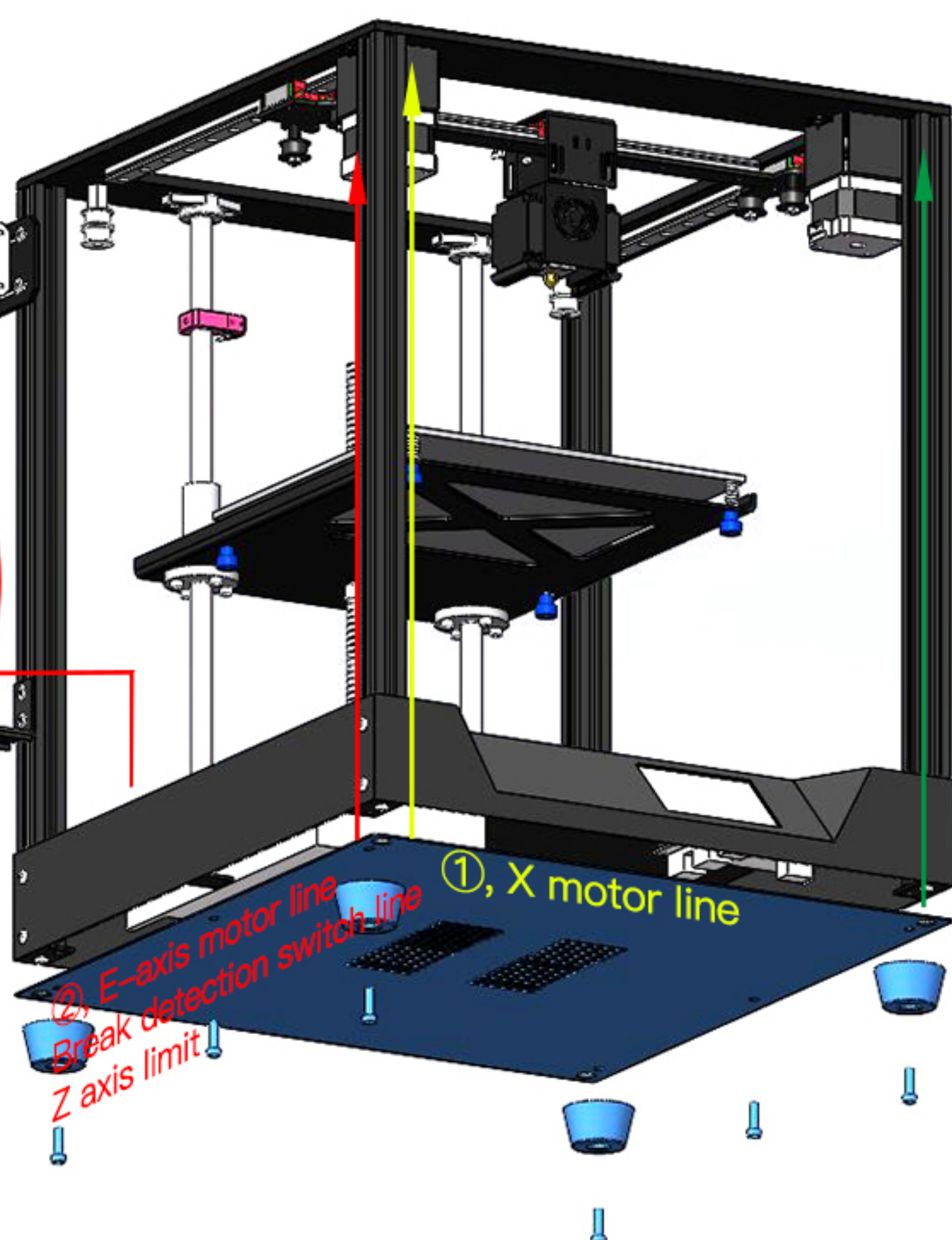
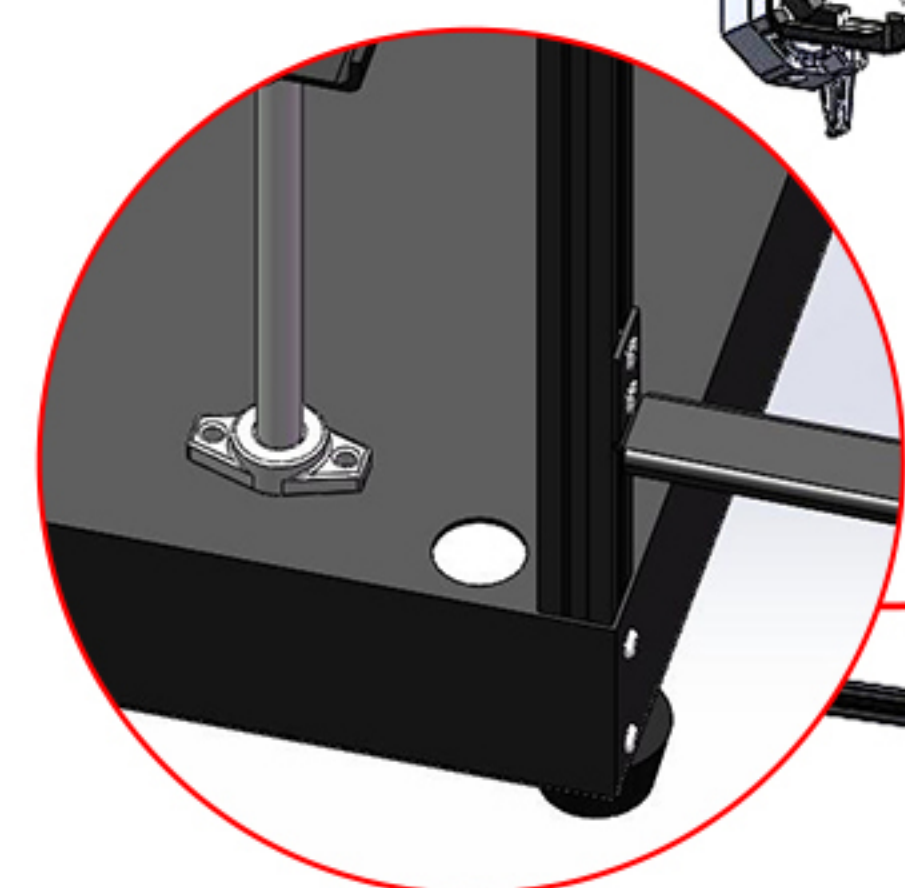

**⚠** Please complete the wiring before installing the base plate.

## 7. How to install timing belt

No.	Name	QTY	Remark
A-4	Belt	1	Half cut

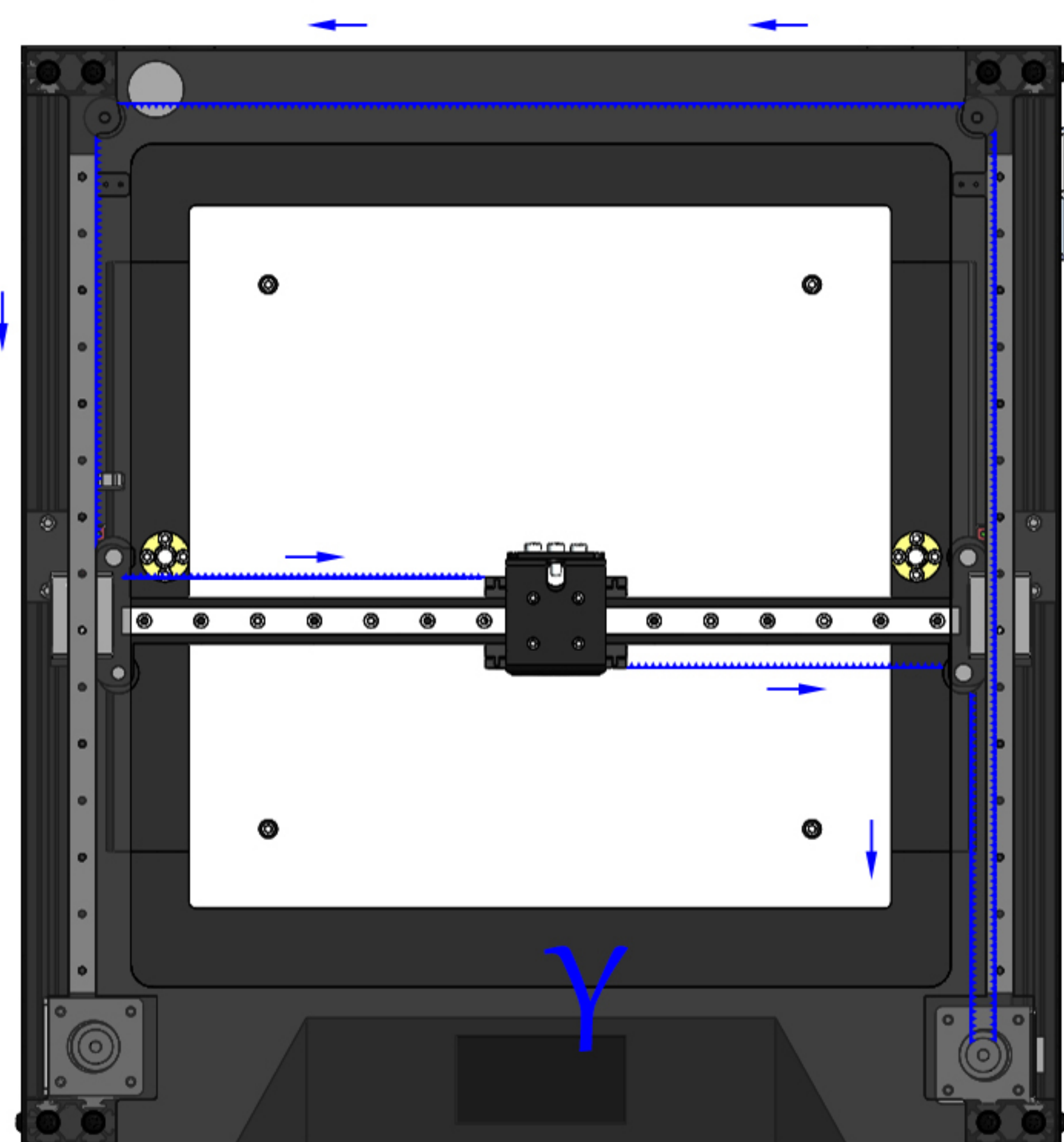
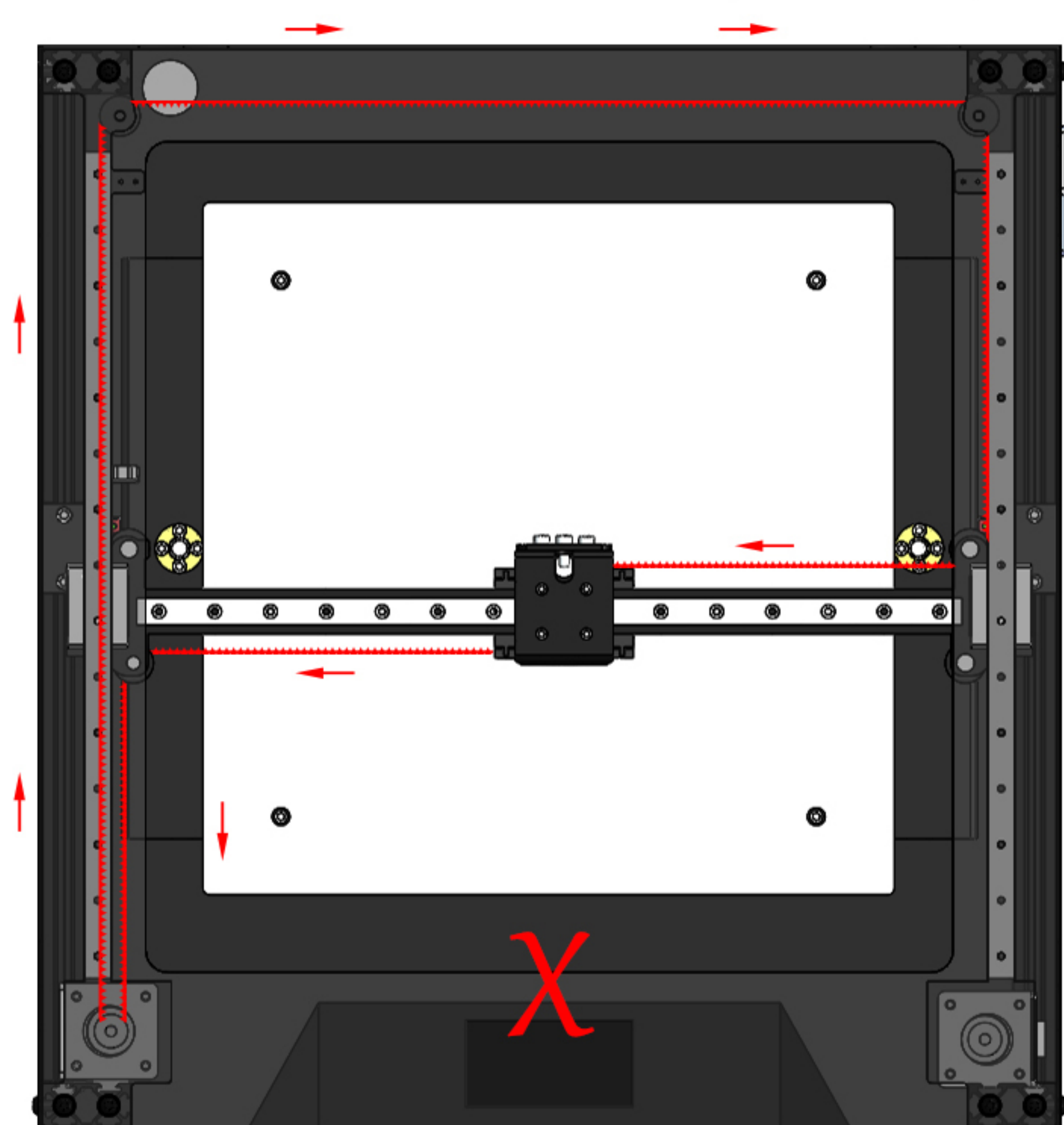

**⚠** Belt tightness will affect print quality, please control the belt tightness. Make sure the belt is installed correctly.

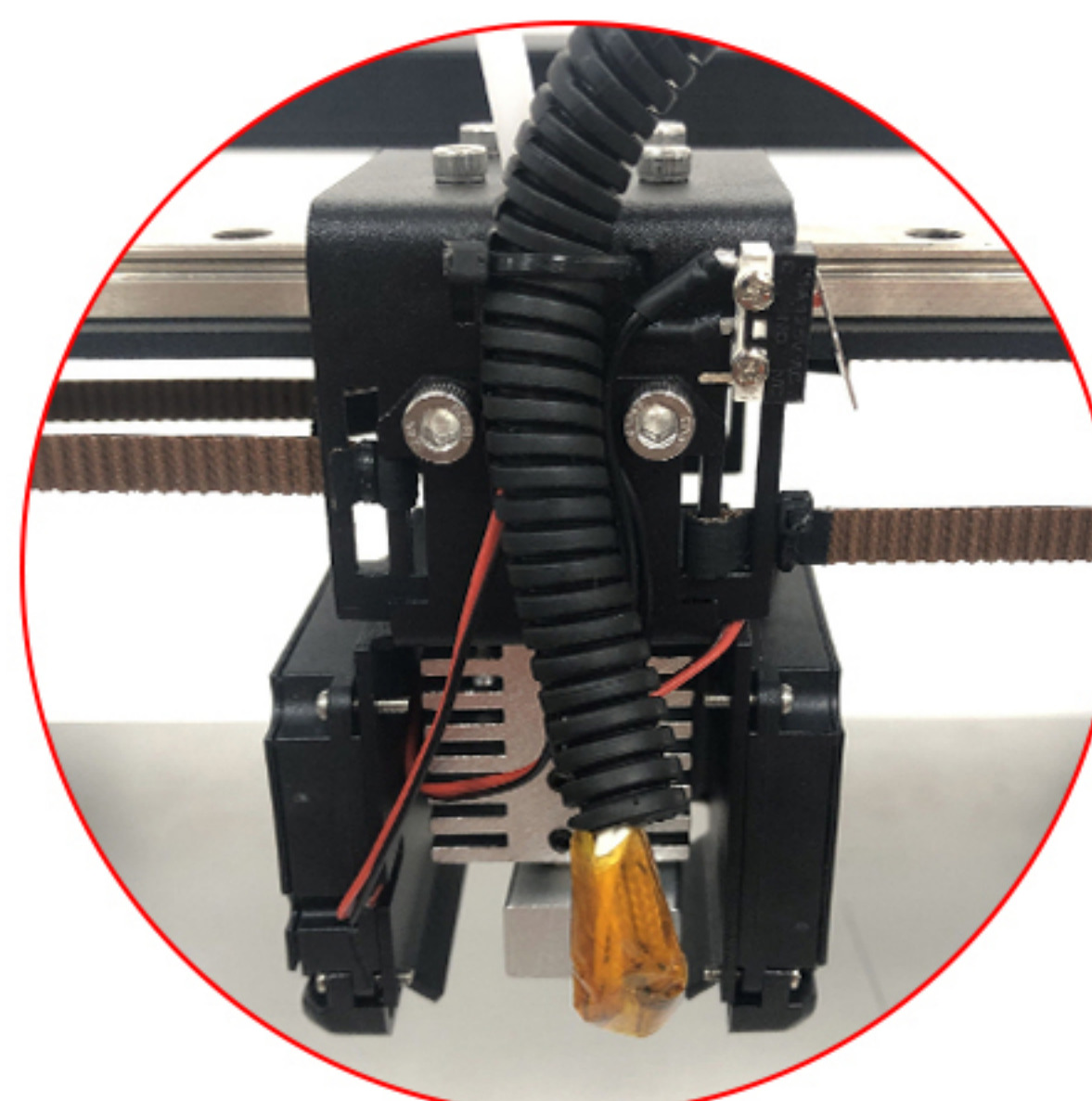



# MOTHERBOARD INSTALLATION METHOD

1. Connect the hotbed power cord to the "hotbed connector".
2. Connect the hot bed thermistor wire to Hot Bed Heat.
3. Connect the X.Y-Endstop switch cable to the "X.Y limit switch".
4. Connect the Z-Endstop switch cable to the "Z Endstop connector".  
(Or use automatic induction switch)
5. Connect the X.Y.E motor cable to the "X.Y.E motor".
6. Connect the radiator cooling fan wire to "12V / 24V rated output".
7. Connect the print model cooling fan wires to the Fan Connector.
8. Connect the hot end heating rod to the "Extrusion Head 1 Port".
9. Connect the hot-end thermistor to "Extrusion head 1".
10. Connect the filament sensor to "Break Detection 1".

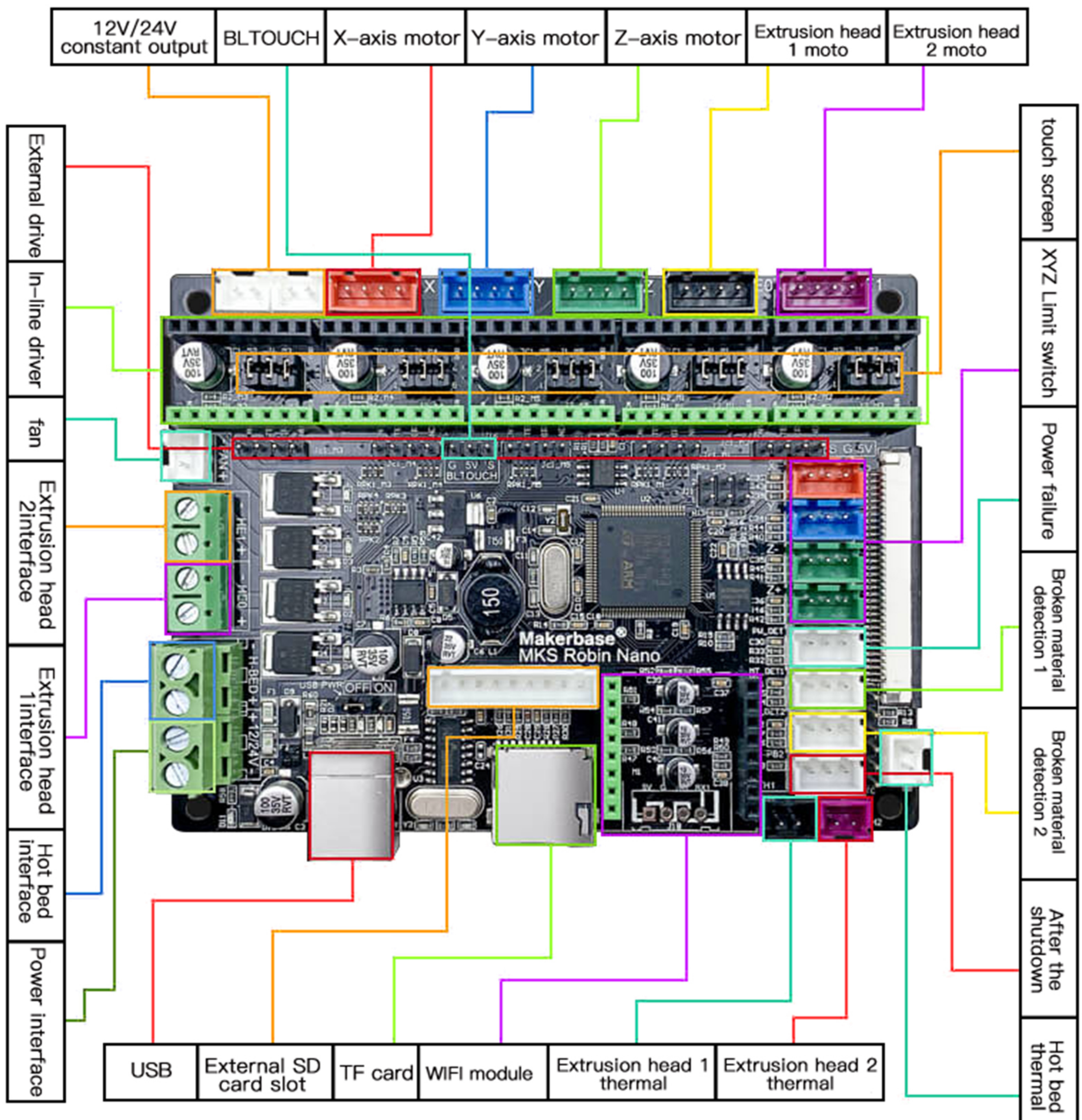

**!** After the wiring is completed, check whether each wiring part is secure.



# AFTER SALES SERVICE

The guarantee period is 12 months from the date of purchase.

## 1. Missing/Damaged/Defective Parts

**a.** Within 7 days of the delivery date, we will replace any parts free of charge including shipping fees.

**b.** After 7 days of the delivery date, we will replace any parts free of charge. But the customer needs to pay the shipping fees.

**2.** Customer Damaged Parts : The customer shall pay for the cost of the parts and the shipping fees.

**3.** Courier company loss, missing, damaged, and defective parts.

**a.** Claims for lost or damaged shipments must be reported to the carrier within the carrier's claim window, the customer needs to inform us within 7 days of the delivery date.

**b.** For any parts lost or damaged during shipping, the customer shall take photos or video and send the information to us.

**c.** Once the Carrier dispute got solved, please provide us with all communications with the carrier. It is the customer's responsibility to keep us up to date with ALL communication with the carrier.

**d.** For Missing Parts, the customer shall fill out a Service Ticket.

**e.** For Damaged Parts, the customer shall fill out a Service Ticket and send us the photos or video.

**f.** If the part is the LCD Panel, Power Supply or Mainboard, the customer shall ship the part back to us and we will send a new part.

If you have any after-sales questions, please contact us as soon as possible and we will reply in time.

Phone: (86) 2398 7110

Website: [www.twotrees3dprinter.com](http://www.twotrees3dprinter.com)

Email: [service@twotrees3dprinter.com](mailto:service@twotrees3dprinter.com)

Facebook: <https://www.facebook.com/groups/twotrees3Dprinter/>

Please check other contents in TF



# FAQ

## 1. Print head is often blocked

Answer: 1. Check whether the PTFE tube is inserted into the bottom of the print head.  
2. Check whether the incision of the Teflon tube is flush  
3. Whether the print head cooling fan is working properly

## 2. The print model layer is severe

Answer: 1. Check the tightness of the belt; 2. Re-install the calibration z-axis screw

## 3. The extruder cannot extrude & uneven extrusion

Answer: 1. Check if the gear on the extruder motor is loose  
2. Whether the motor cable is connected correctly  
3. Whether the filament are installed correctly  
4. Whether the heating temperature matches the filament

## 4. Material cutout detection cannot be used

Answer: 1. Check if the wiring is correct  
2. Check the configuration file to change the high or low level, or ask the customer service for the correct configuration file

## 5. The correct use of automatic leveling

Answer: Automatically leveling the first point and triggering the z-axis limit switch in the future will stop leveling this action

## 6. The motor rotates in the wrong direction

Answer: 1. Please make sure the wiring is correct and check the configuration file  
2. Modify the motor direction through the configuration file

## 7. Z-axis noise

Answer: 1. Please add grease to lubricate



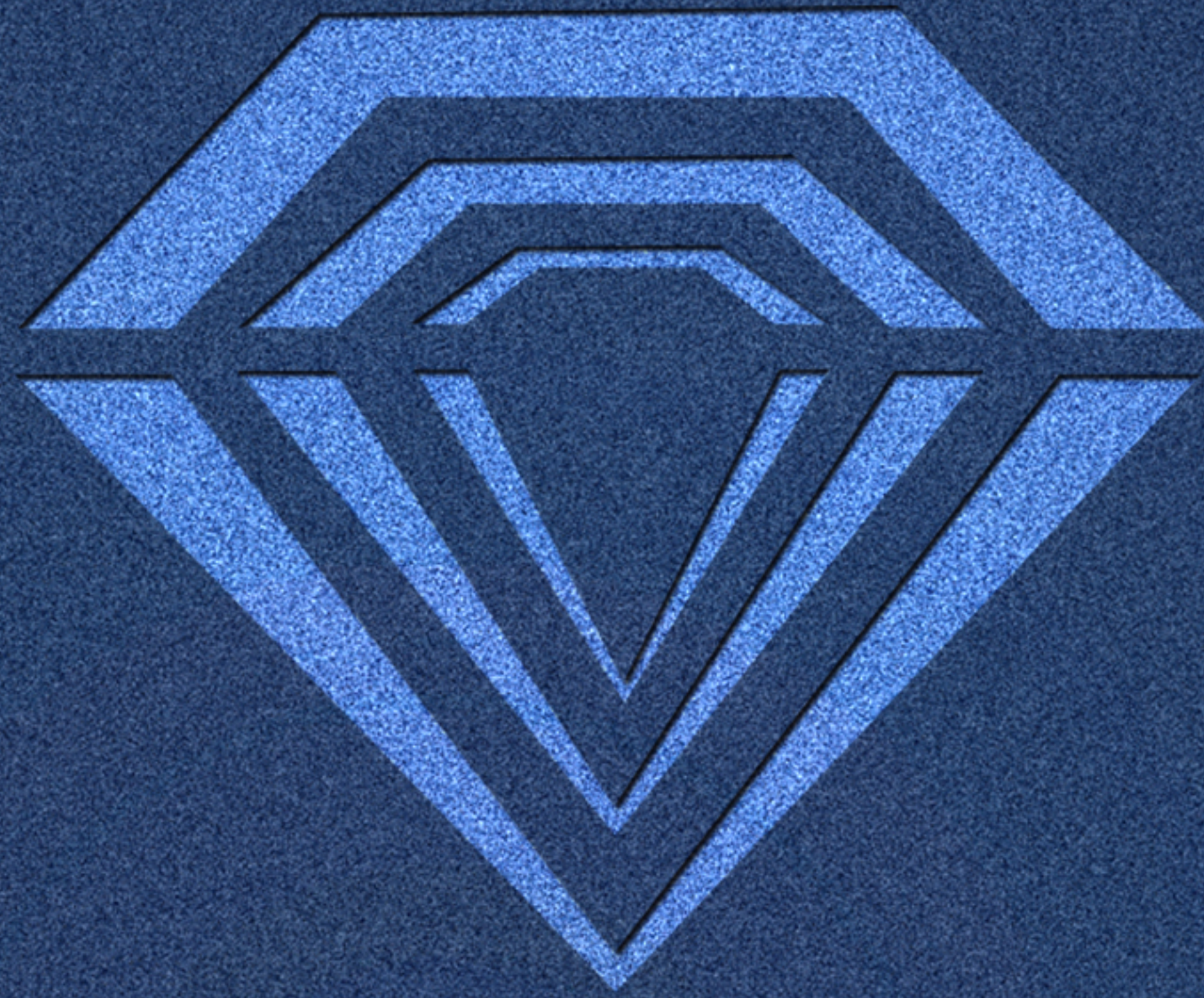

*SAPPHIRE PRO*

