

HOME Automation Card for Raspberry Pi
USER'S GUIDE VERSION 1.2

GENERAL DESCRIPTION.....	2
WHAT IS IN YOUR KIT.....	4
QUICK START-UP GUIDE.....	4
BOARD LAYOUT.....	5
STACK LEVEL JUMPERS.....	6
POWER REQUIREMENTS.....	7
HARDWARE WATCHDOG.....	8
MULTI-FUNCTION OUTPUTS.....	9
OPEN DRAIN OUTPUTS WITH PWM.....	9
0-10V LIGHT DIMMERS (preliminary).....	9
RANGE FINDERS (preliminary).....	10
NEOPIXEL LED STRIPS.....	11
DS18B20 TEMPERATURE SENSOR.....	11
HARDWARE SPECIFICATIONS.....	12
MECHANICAL SPECIFICATIONS.....	13
SOFTWARE SETUP.....	14
ANALOG INPUTS/OUTPUTS CALIBRATION.....	15
ADD-ON CARDS.....	16
BREAK-OUT CARD TYPE-1.....	16
BREAK-OUT CARD TYPE-2.....	17
DIN-RAIL KIT for RASPBERRY PI.....	18
8-RELAY CARD.....	19
4-RELAY CARD.....	20
IO-PLUS SELF TEST CARD.....	21

GENERAL DESCRIPTION

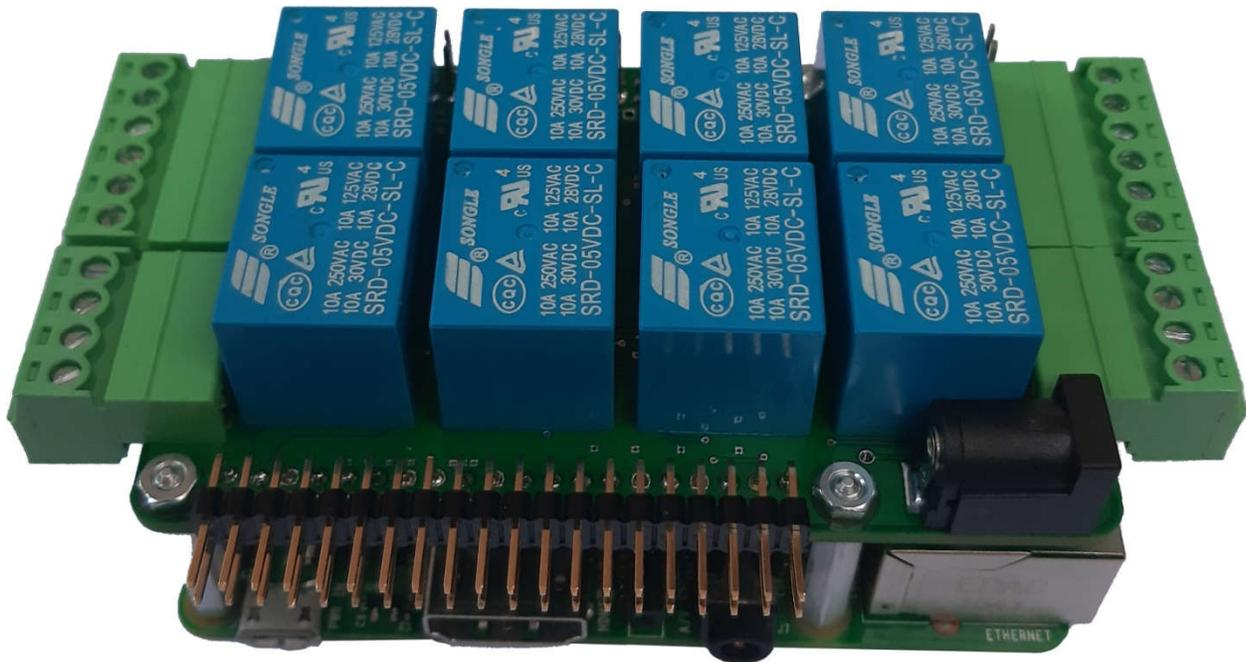

The IO-PLUS is a stackable expansion card for Raspberry Pi. The IO-PLUS is compatible with all Raspberry Pi versions from Zero to 4. It is a simple, low-cost and expandable solution for your home automation needs.

SPECIFICATIONS

- Eight Relays with status LEDs and Pluggable Connectors
- Eight 12 bit A/D Inputs
- Eight Optically Isolated Digital Inputs
- Four multi-function outputs configurable as:
 - Four open drain outputs with PWM capabilities (30V/5.7A MOSFETS) or
 - Four 0-10V light dimmers (with external 12V power supply) or
- Four GPIO's directly from the on-board STM32F030 microcontroller. These are independent of the Raspberry Pi GPIOs.
- On-board Hardware Watchdog capable of power cycling the Raspberry Pi.
- On-board Resettable Fuse
- Full hardware self-test with loop-back card included in the package
- Separate powering of each board
- Command Line and Python Drivers

Up to eight IO-PLUS cards can be stacked on top of one Raspberry Pi. Each IO-PLUS card is equipped with a 32-bit STM32F030 running at 48 MHz. The IO-PLUS cards share a serial I2C bus using only two of the

Raspberry Pi's GPIO pins to manage all eight cards. This feature leaves the remaining 24 GPIOs available for the user.

The four DAC outputs and the four Open Drain Outputs share the same control lines from the on-board processor. The DAC outputs can be used to control 0-10V dimmers, using an external 12V power supply.

The Open Drain Outputs can be used to control analog or digital loads up to 24V and 3A. The DAC and Open Drain outputs can be mixed in any combination, but make sure that only the intended outputs are connected to live loads.

Sequent Microsystems makes available several other related products that are compatible with the IO-PLUS card and allow you to extend your base IO-PLUS system in a cost-effective way. These products include:

- 8-RELAYS Card – Similar to the IO-PLUS, but lower cost because it has only relay outputs.
- 4-RELAYS Card – A heavy duty relay card capable of switching 10A at 250V.
- IO-PLUS Self Test Card – Loops inputs and output so that you can test the function of your IO-PLUS card.
- BREAK-OUT Card Type-1: Provides screw terminal access to all I/O lines on the either the IO-PLUS I/O pins or the Raspberry Pi connector.
- BREAK-OUT Card Type-2: Brings out all 40 Raspberry Pi connections to spring-loaded connectors.
- DIN-Rail Kit for Raspberry Pi – Allows you to mount your Raspberry Pi system on industry standard DIN rails.

Details of the add on cards are included in the final section of this document.

WHAT IS IN YOUR KIT

1. IO-PLUS add-on card for Raspberry Pi
2. Mounting hardware
 - a. Four M2.5x18mm male-female nylon standoffs
 - b. Four M2.5x5mm nylon screws
 - c. Four M2.5 nylon nuts
3. Two jumpers. You do not need the jumpers when using only one IO-PLUS card. See STACK LEVEL JUMPERS section on page 4 if you plan to use multiple IO-PLUS cards.
4. Loop-back self test card.
5. Two 6-pin female mating connectors for NO-NC relays
6. Two 4-pin female mating connectors for NO relays

QUICK START-UP GUIDE

1. Plug your IO-PLUS card on top of your Raspberry Pi and power up the system.
2. Enable I2C communication on Raspberry Pi using raspi-config.
3. Install the io-plus software from github.com:
 - a. ~\$ `git clone https://github.com/SequentMicrosystems/ioplus-rpi.git`
 - b. ~\$ `cd /home/pi/ioplus-rpi`
 - c. ~/ioplus-rpi\$ `sudo make install`
4. ~/ioplus-rpi\$ `ioplus`

The program will respond with a list of available commands.

BOARD LAYOUT

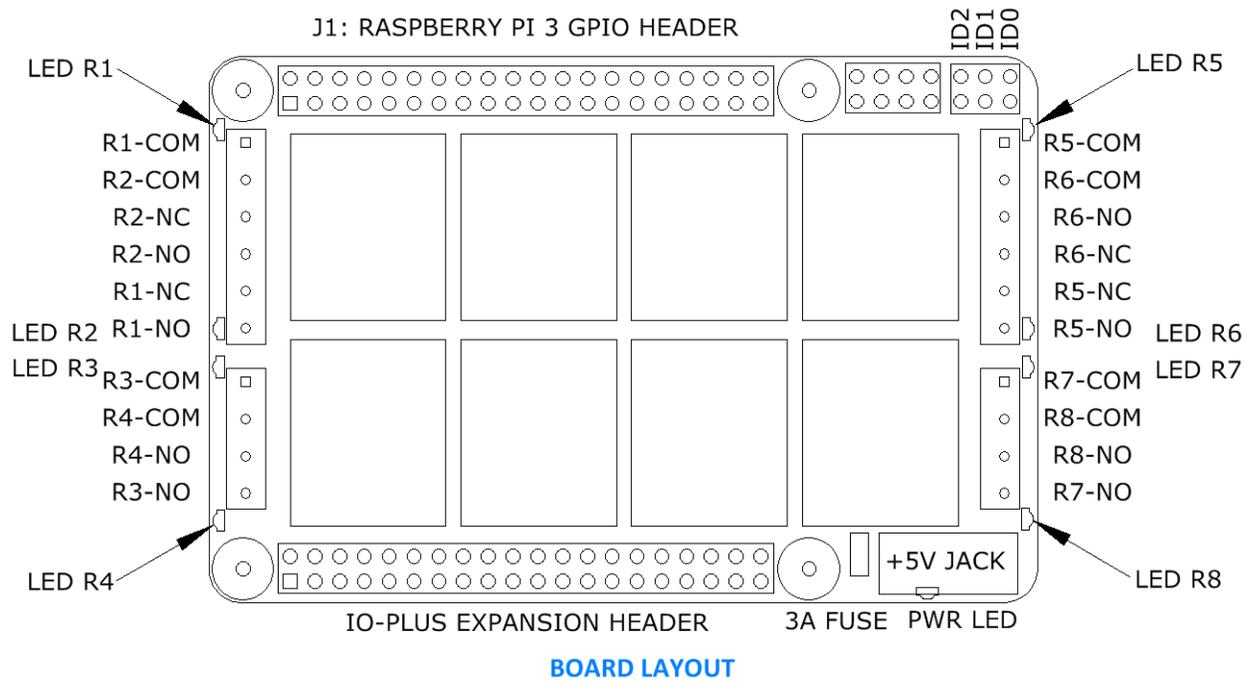

Your IO-PLUS card comes with appropriate mounting hardware. Up to eight IO-PLUS cards can be stacked on top of one Raspberry Pi.

Eight LEDs (LED R1-R8) indicate the status of their respective relay. An LED is lit when the corresponding relay is energized.

STACK LEVEL JUMPERS

Up to eight IO-PLUS cards may be stacked on your Raspberry Pi module. Each card is identified by jumpers you install to indicate the level in the stack. Cards can be installed on Raspberry Pi in any order. The 7 position jumper installed in the upper right corner of the IO-PLUS card has the left four positions factory reserved. The right three positions are selecting the stack level of the card, as follows:

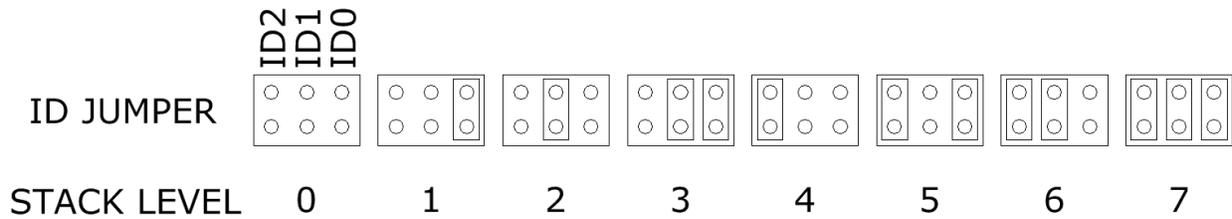

POWER REQUIREMENTS

The IO-PLUS card requires +5V power, supplied either from the Raspberry Pi expansion bus, or from its own 2.1mm power jack. The on-board relays are powered by the +5V (See Schematics). A local 3.3V regulator powers the rest of the circuits (See schematic 9).

Raspberry Pi current consumption: 250 mA @ +5V (could be as high as 2A)

IO-PLUS current consumption: 50 mA @ +5V (all relays OFF)

750 mA @ +5V (all relays ON)

The jack which powers the IO-PLUS card can handle up to 3A and is protected by a 3A resettable fuse. We recommend using this jack with a 5V regulated power supply rated at 3A or higher. The tip is +5V and the ring is ground. (see Schematics).



The IO-PLUS card can be stacked up to eight levels. A multi-stack configuration can be powered from any of the cards. An eight stack needs 400 mA for electronic circuits, leaving 2.5A for relays. With some margin of error, not more than 24 relays can be ON at the same time.

If your application requires more relays to be ON at the same time, we recommend using a power supply rated 5A or higher, with a split cable like the one in this picture.

HARDWARE WATCHDOG

The IO-PLUS card contains a built-in hardware watchdog which will guarantee that your mission-critical project will recover and continue running even if Raspberry Pi software hangs up. After power up the watchdog is disabled, and becomes active after it receives the first reset.

The default timeout is 120 seconds. Once activated, if it does not receive a subsequent reset from Raspberry Pi within 2 minutes, the watchdog cuts the power and restores it after 10 seconds.

Raspberry Pi needs to issue a reset command on the I2C port before the timer on the watchdog expires. The timer period after power up and the active timer period can be set from the command line. The number of resets is stored in flash and can be accessed or cleared from the command line. All the watchdog commands are described by the online help function.

MULTI-FUNCTION OUTPUTS

Due to the limited pin-out resources on the processor, the four multi-purpose outputs use the same IO pins but connect to different pins on the IO connector. You cannot connect loads to both types of outputs at the same time.

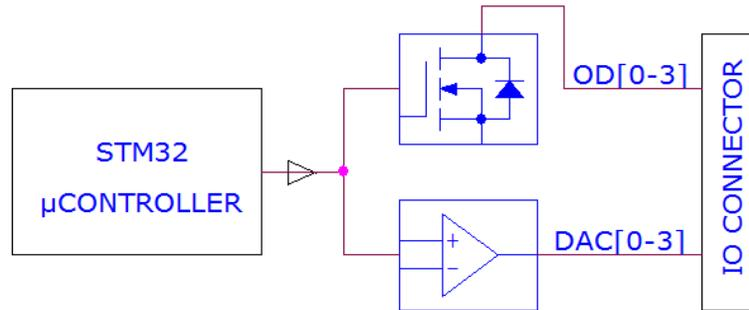

MULTI-PURPOSE OUTPUTS CONFIGURATION

OPEN DRAIN OUTPUTS WITH PWM

Use this configuration to power loads up to 4A. You must provide the external power supply of up to 24V. You can use the command system to turn the outputs on and off, or proportional control using PWM. When using PWM you can control both the period and the fill-factor.

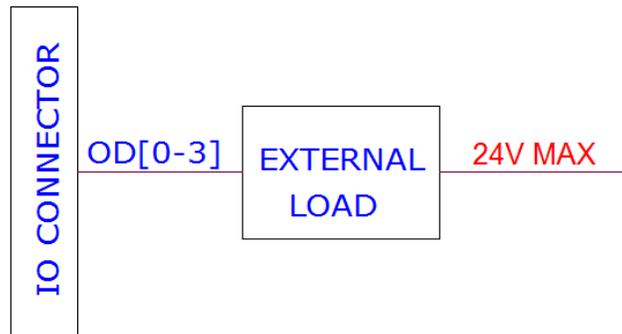

OPEN DRAIN OUTPUTS CONFIGURATION

0-10V LIGHT DIMMERS (preliminary)

The DAC outputs support both existing standards for 0-10V dimmers. The IEC standard for current sink controls, 60929 Annex E, and the ESTA E1.3 standard for current source controls. In both configuration the user must supply an external 12V/500mA power supply. The IOPLUS-PLUS board can supply up to 10mA on each of the four DAC outputs. In the sink configuration the board can drive up to five loads per

channel, for a total of 20 loads. The output voltage range is 1-10V. In the source configuration the board can drive one load per channel, for a total of four loads, and the output voltage range is 0 to 10V.

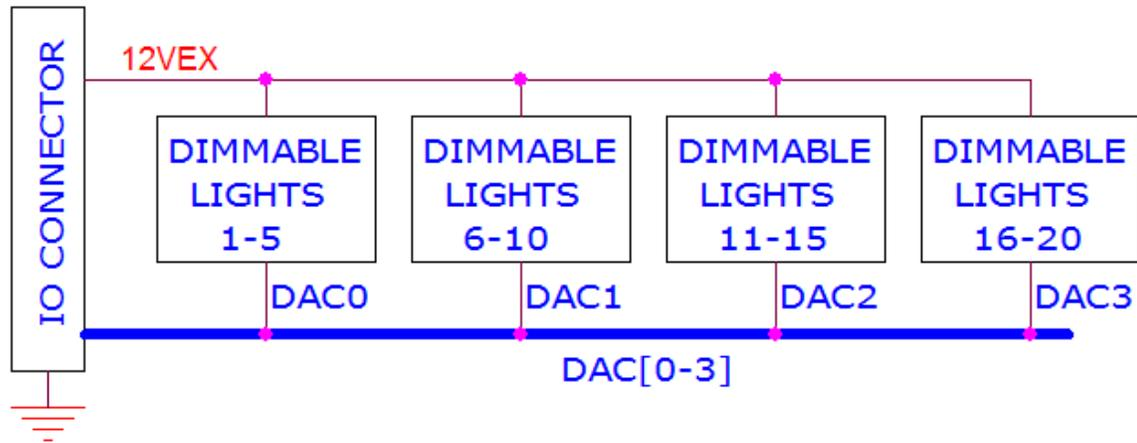

CURRENT SINK CONFIGURATION

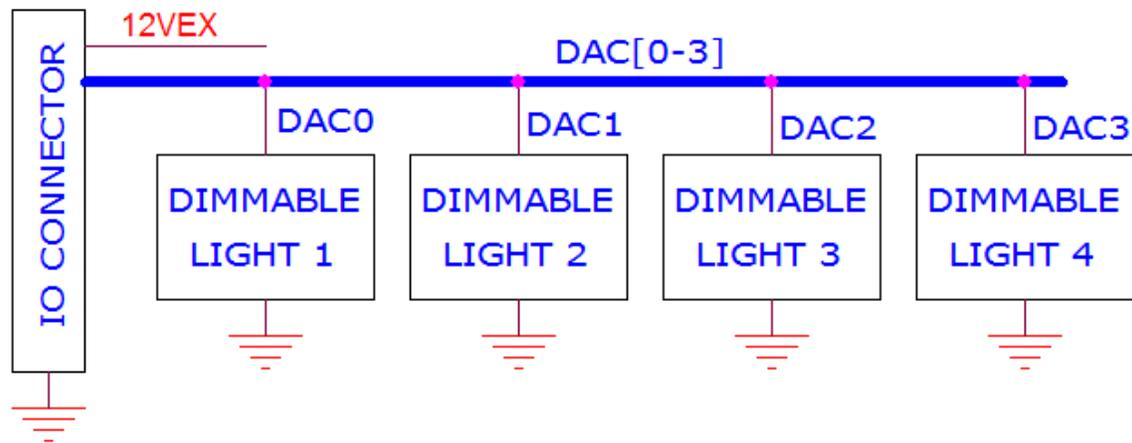

CURRENT SOURCE CONFIGURATION

RANGE FINDERS (preliminary)

The ODO output can be used to drive four HC-SR04 ultrasonic transducers. The four GPIO inputs are used to read the return signal, thus enabling the IOPLUS-PLUS card to simultaneously read distances to four objects. Connect all four Trigger inputs to the ODO output, and the four Echo outputs to the GPIO[0-3] signals.

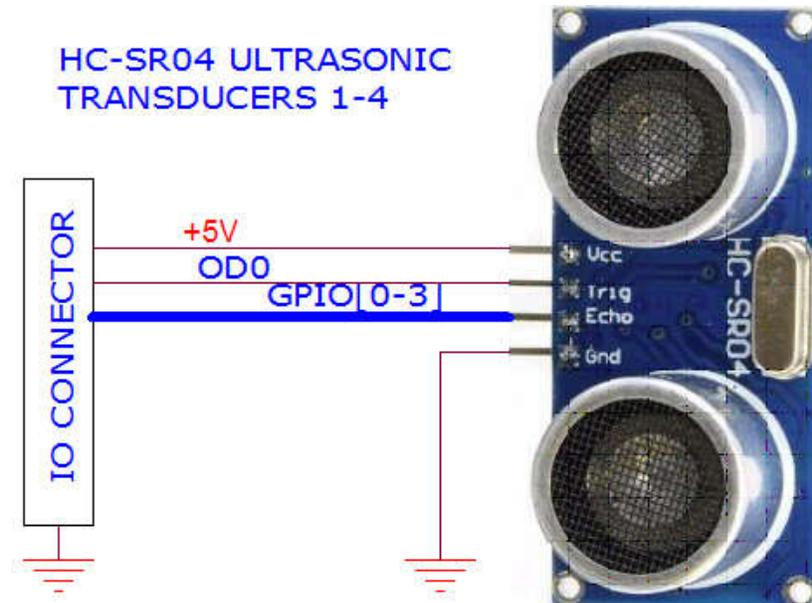

RANGE FINDERS CONFIGURATION

NEOPIXEL LED STRIPS

Preliminary firmware

DS18B20 TEMPERATURE SENSOR

Preliminary firmware

HARDWARE SPECIFICATIONS

ON BOARD RESETTABLE FUSE: 3A

OPEN DRAIN OUTPUTS:

- Maximum output current: 3A
- Maximum output voltage: 24V

ANALOG INPUTS:

- Maximum input voltage: 3.3V
- Input Impedance: 50 K Ω
- Resolution: 12 bits
- Sample rate: 250 samples/sec.

GPIO LINES:

- Directly from the on-board STM32F030 microprocessor under control of the software

DAC OUTPUTS:

- Resistive load: Minimum 1 K Ω
- Accuracy: $\pm 1\%$

OPTO-ISOLATED INPUTS:

- Input Forward Current: Typical 5 mA, maximum 50 mA
- Input Series Resistor: 1K
- Input Reverse Voltage: Max. 5V
- Input Forward Voltage: 1.25V @ 10 mA
- Isolation Resistance: Minimum $10^{12} \Omega$

RELAY OUTPUTS

- Maximum current/voltage: 5A/48V

POWER CONSUMPTION:

- 50 mA @ +5V (all relays OFF)
- 750 mA @ +5V (all relays ON)

For details on connecting to the various inputs and outputs of the IO-PLUS the user should refer to the schematics provided here and to the data sheets for the device implementing specific the input or

output (e.g. for the Opto-Isolated Inputs one would refer to the TLP-29104 data sheet.) It is the user's responsibility to maintain input and output voltages and currents within the range specified by the manufacturer's documentation.

MECHANICAL SPECIFICATIONS

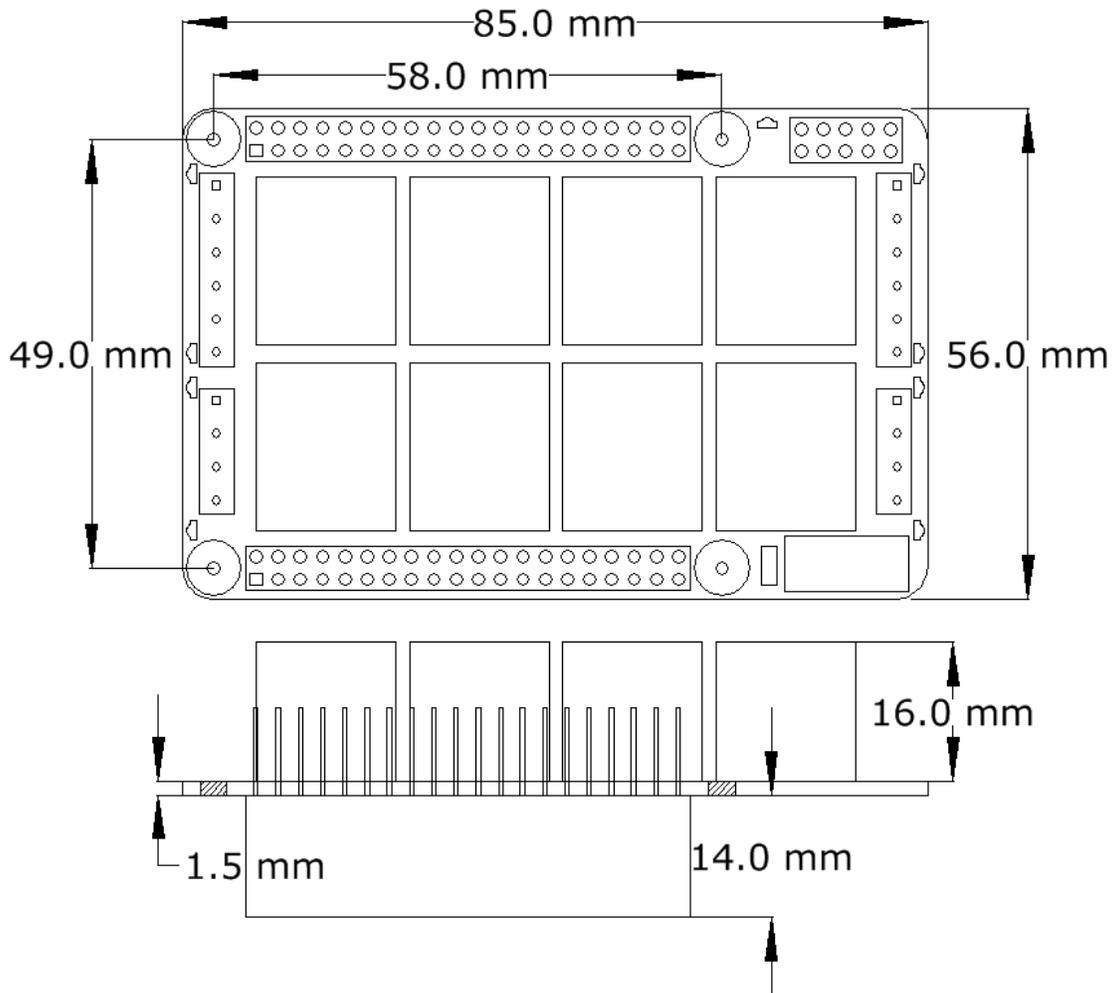

IO-PLUS and its compatible add-on cards can be mounted in any order. You may also intermix cards from other vendors, assuming they do not use the same I2C address (see STACK LEVEL JUMPERS section on page 6). It is recommended that you power the Raspberry Pi and the IO-PLUS cards from the same supply, and that the IO-PLUS card being powered is the card nearest the Raspberry Pi.

SOFTWARE SETUP

1. Have your Raspberry Pi ready with the [latest OS](#).

2. Enable I2C communication:

```
~$ sudo raspi-config
```

1. Change User Password	Change password for default user
2. Network Options	Configure network settings
3. Boot Options	Configure options for start-up
4. Localisation Options	Set up language and regional settings to match..
5. Interfacing Options	Configure connections to peripherals
6. Overclock	Configure overclocking for your Pi
7. Advanced Options	Configure advanced settings
8. Update	Update this tool to the latest version
9. About raspi-config	Information about this configuration
P1	Camera Enable/Disable connection to the Raspberry Pi Camera
P2	SSH Enable/Disable remote command line access to your Pi
P3	VNC Enable/Disable graphical remote access to your Pi using...
P4	SPI Enable/Disable automatic loading of SPI kernel module
P5	I2C Enable/Disable automatic loading of I2C kernel module
P6	Serial Enable/Disable shell and kernel messages to the serial port
P7	1-Wire Enable/Disable one-wire interface
P8	Remote GPIO Enable/Disable remote access to GPIO pins

3. Install the io-plus software from github.com:

```
~$ git clone https://github.com/SequentMicrosystems/ioplus-rpi.git
```

5.

```
~$ cd /home/pi/ioplus-rpi
```

6.

```
~/ioplus-rpi$ sudo make install
```

7.

```
~/ioplus-rpi$ ioplus
```

The program will respond with a list of available commands.

Type "**ioplus -h**" for online help.

After installing the software, you can update it to the latest version with the commands:

1.

```
~$ cd /home/pi/ioplus-rpi
```

2.

```
~/ioplus-rpi$ git pull
```

3.

```
~/ioplus-rpi$ sudo make install
```

ANALOG INPUTS/OUTPUTS CALIBRATION

All the analog inputs and outputs are calibrated at the factory within $\pm 1\%$, but firmware commands permit you to re-calibrate the board, or to calibrate it to better match your requirements. Each input is calibrated at two points and the internal software interpolates the voltage linearly between these two points. Calibration data is stored in on-board Flash ROM. For the best accuracy you should select one point close to the low end of the range of expected inputs or output and the other at the high end of the range.

To calibrate the inputs, the user must provide an accurate DC voltage. (Example: to calibrate 0-10V inputs, the user must provide a 10V adjustable power supply). To calibrate the outputs, the user must issue a command to set the output to a desired value, measure the result and issue the calibration command to store the value.

The values are stored in flash and the input curve is assumed to be linear. If a mistake is made during calibration by typing the wrong command, a RESET command can be used to reset all the channels in the corresponding group to factory values. After RESET calibration can be restarted.

The board can be calibrated without an external voltage reference, by first calibrating the outputs and then routing the calibrated outputs to corresponding inputs. The following commands are available for calibration:

Apply 0.1V to Analog Inputs

CALIBRATE ANALOG INPUTS TO LOW LIMIT: ioplus <id> cuin <channel> 0.1

Apply 3.2V to Analog Inputs

CALIBRATE ANALOG INPUTS TO HIGH LIMIT: ioplus <id> cuin <channel> 3.2

RESET CALIBRATION OF ANALOG INPUTS: ioplus <id> rcuin

SET 0-10V OUTPUTS TO LOW LIMIT: ioplus <id> uout <channel> 0.5

CALIBRATE 0-10V LOW LIMIT: ioplus <id> cuout <channel> <actual_value>

SET 0-10V OUTPUTS TO HIGH LIMIT: ioplus <id> uout <channel> 9.5

CALIBRATE 0-10V HIGH LIMIT: ioplus <id> cuout <channel> <actual_value>

RESET CALIBRATION OF 0-10V OUTPUTS: ioplus <id> rcuout

ADD-ON CARDS

BREAK-OUT CARD TYPE-1

The Break-out Type-1 card plugs into the IO-PLUS expansion connector and brings all the IO pins to screw-type terminal blocks. It can be used also as a break-out card for the Raspberry Pi GPIO connector. The card also has a prototype area for your electronic experiments.

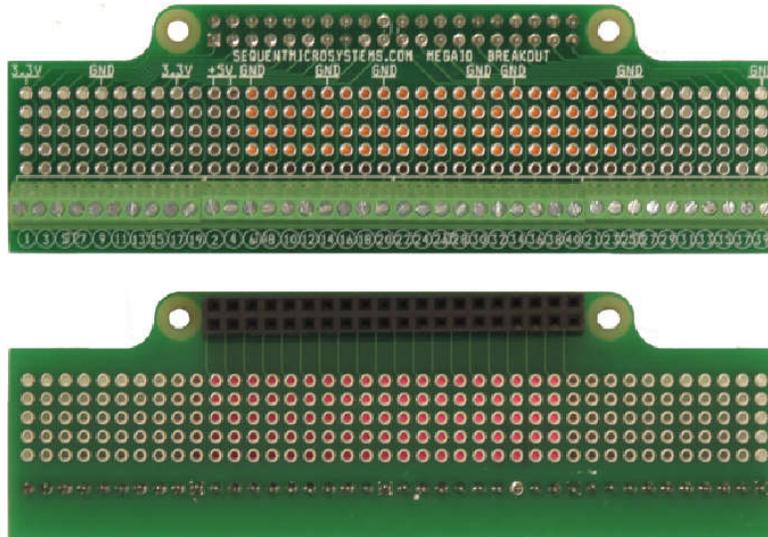

BREAK-OUT CARD TYPE-1, FRONT AND BACK

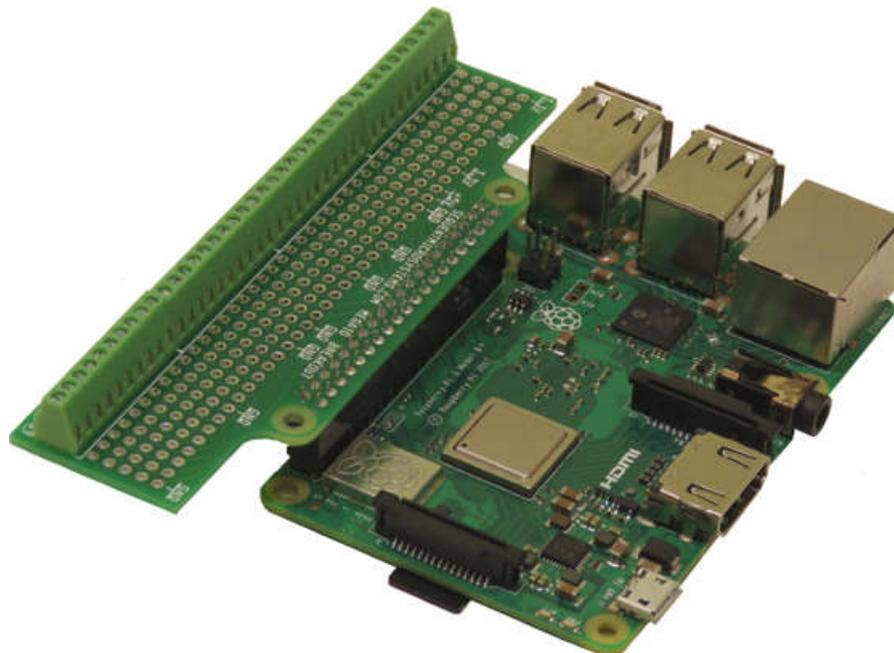

BREAK-OUT CARD TYPE-1 INSTALLED ON RASPBERRY PI

BREAK-OUT CARD TYPE-2

The Break-out card Type-2 plugs into the Raspberry Pi 40 pin connector and brings all the IO pins to spring-loaded connectors. A prototype area permits is also available for design experiments.

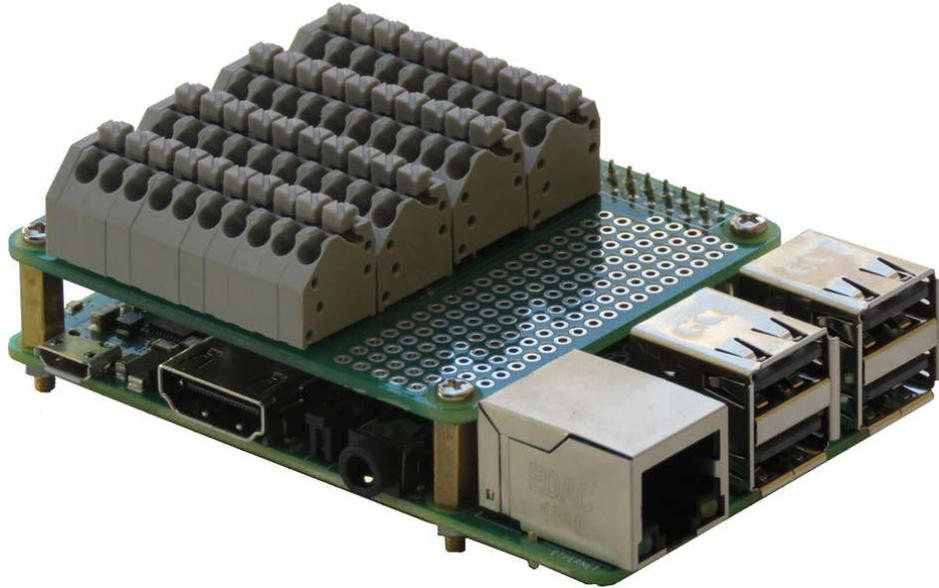

The Break-out Type2 comes with a credit card size legend of the GPIO pin-outs:

+3.3V	GND	GPIO02	GPIO03	GPIO04	GPIO05	GPIO06	GPIO07	GPIO08	GND
+3.3V	GND	GPIO09	GPIO10	GPIO11	GPIO12	GPIO13	GPIO14	GPIO15	GND
+5V	GND	GPIO16	GPIO17	GPIO18	GPIO19	GPIO20	GPIO21	GPIO22	GND
+5V	GND	GPIO23	GPIO24	GPIO25	GPIO26	GPIO27	IO_SD	IO_SC	GND

WWW.SEQUENTMICROSYSTEMS.COM

+3.3V :01	02: +5V
GPIO02 :03	04: +5V
GPIO03 :05	06: GND
GPIO04 :07	08: GPIO14
GND :09	10: GPIO15
GPIO17 :11	12: GPIO18
GPIO27 :13	14: GND
GPIO22 :15	16: GPIO23
+3.3V :17	18: GPIO24
GPIO10 :19	20: GND
GPIO09 :21	22: GPIO25
GPIO11 :23	24: GPIO08
GND :25	26: GPIO07
ID_SD :27	28: ID_SC
GPIO05 :29	30: GND
GPIO06 :31	32: GPIO12
GPIO13 :33	34: GND
GPIO19 :35	36: GPIO16
GPIO26 :37	38: GPIO20
GND :39	40: GPIO21

WWW.SEQUENTMICROSYSTEMS.COM

DIN-RAIL KIT for RASPBERRY PI

The DIN-Rail Kit permits mounting any Raspberry Pi on a DIN-Rail. It contains all the necessary screws and stand-offs.

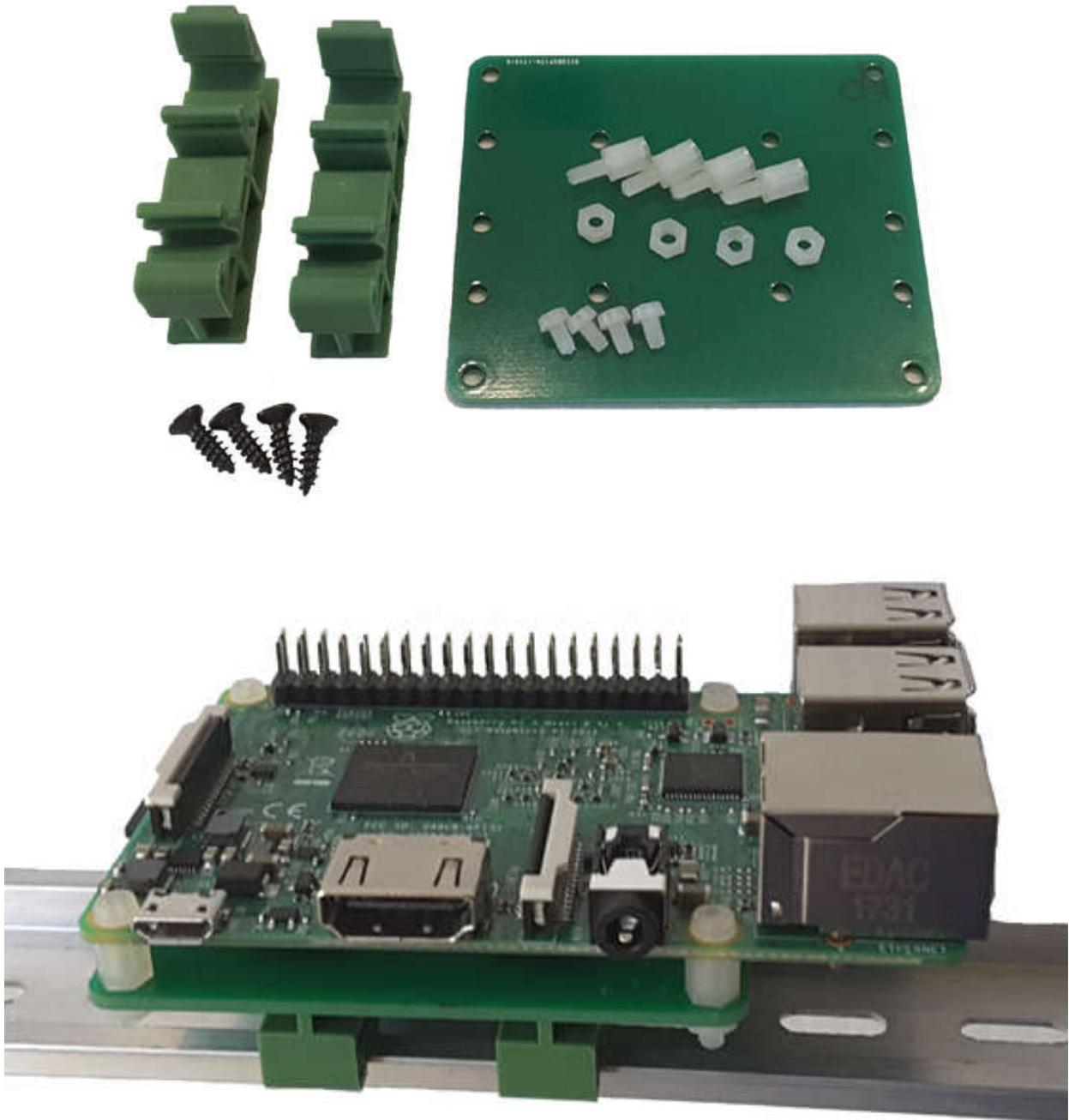

8-RELAY CARD

The 8-RELAY card can be mixed with the IO-PLUS card when more relays are needed, without adding more IO functions. The board is similar with the IO-PLUS, but all the IO functions have been removed in order to save cost. Up to eight IO-PLUS and 8-RELAY cards can be mixed in any configuration.

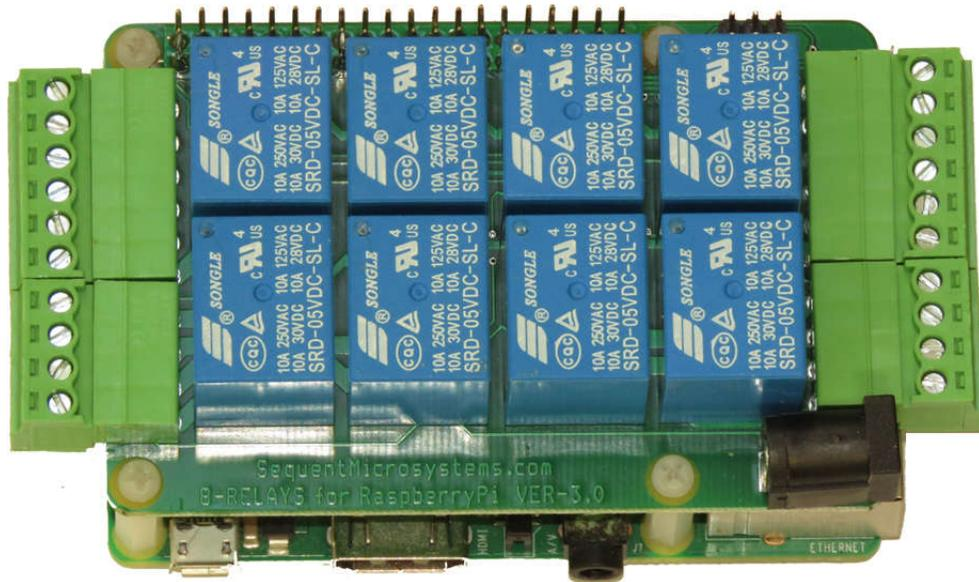

Four relays have three contacts each brought to the pluggable connectors (NO-COMM-NC) and can switch loads of up to 4A and 125V.

The other four relays have two contacts each available (COMM-NO) and can switch loads of up to 8A and 125V.

4-RELAY CARD

The 4-RELAY card can be mixed with the IO-PLUS and can switch loads of up to 10A and 250V.



IO-PLUS SELF TEST CARD

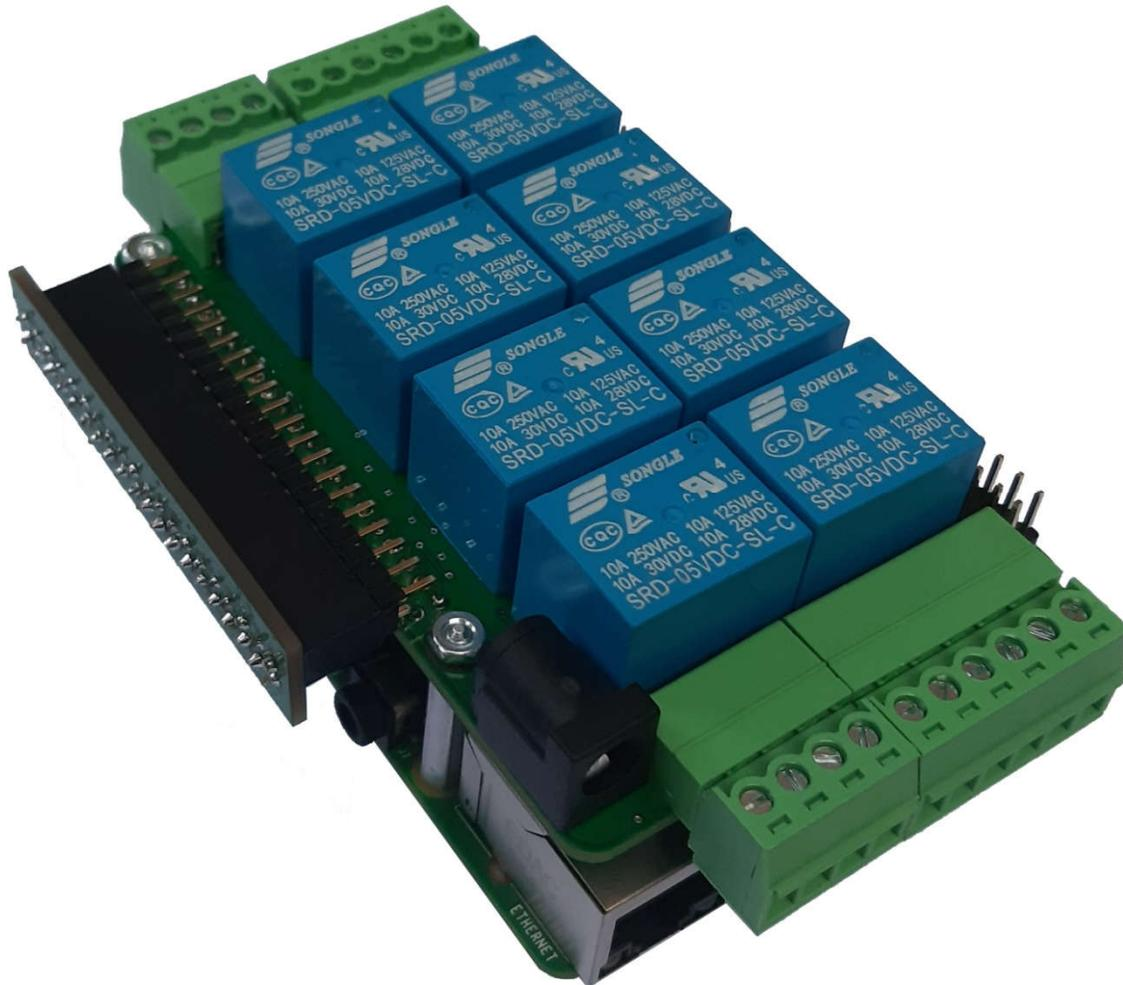

The IO-Plus card can be tested using the loopback card included in the package. Insert the loopback card into the IO Connector of the IO-Plus card and run the command:

```
ioplus [stack_level] test
```

The schematic of the loopback card is included at the end of this document (see Schematic 13)