

SmartElex

ATmega32 Development Board

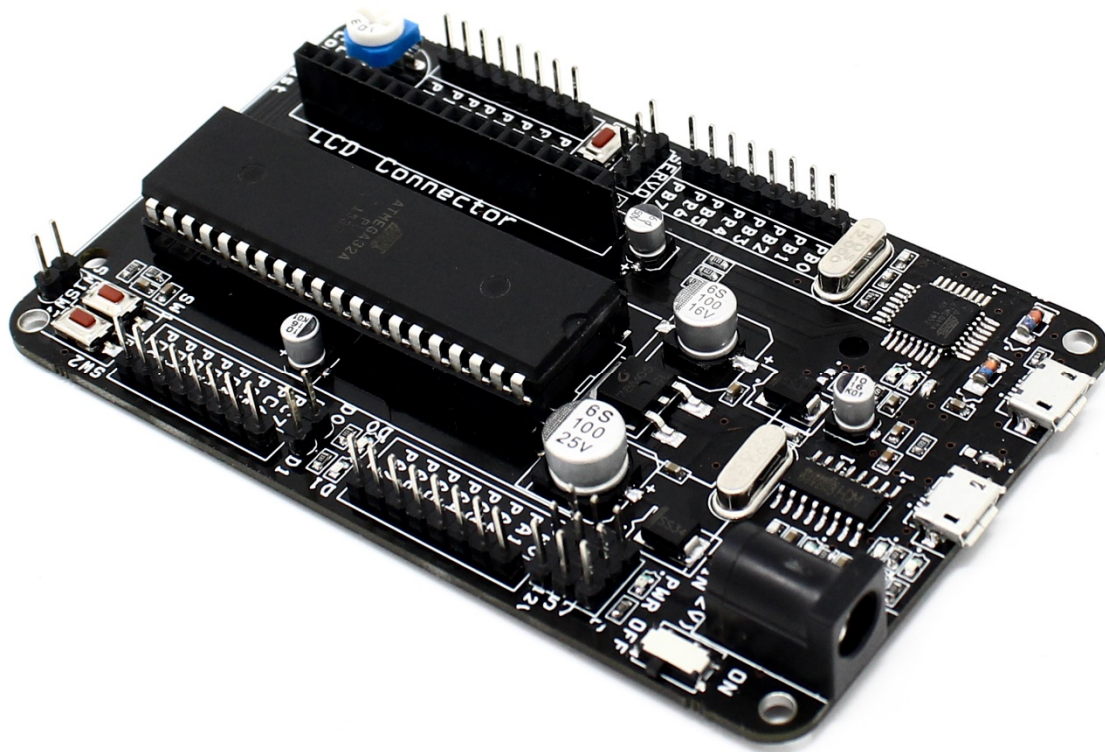

INDEX

1. Description
2. Features
3. ATMEGA32A Pin diagram and features
4. Product Layout
5. Reset and Crystal circuit
6. Examples
7. Warranty

1. Description :-

The SmartElex ATmega32 Development Board can be used to evaluate and demonstrate the capabilities of AVR ATmega32 microcontroller. The MCU socket on board provides support for 40 pin DIP package of AVR ATmega32 controller. This board designed for General Purpose application.

Board has on board power supply circuit, Micro USB for USBASP programmer, Micro USB port for serial communication with computer and other serial device, power status LED (RED), Reset switch, Two User switch, Two User LED, and port extensions for all 4 ports. You can power the Board through the DC plug-in jack. The on-board power regulator can handle anything from 9 to 12VDC.

2. Features:

1. Recommended Input Voltage: 12V
2. Min-Max Input Voltage: 9-15V
3. 5 mm standard DC plug-in jack for Input supply
4. On-board 5V regulator (78M05) circuit.
5. On-Board power supply on-off switch
6. Power Status LED (RED)
7. User LED D0, D1 connected to any port pin through D0, D1 Jumper respectively.
8. User Switch SW1, SW2 connected to any port pin through SW1, SW2 Jumper respectively.
9. On-board 12 MHz crystal
10. Port extensions for all ports with detailed pin labelling for easy identification of pins
11. On-board USB TO Serial - CH340 Chip.
12. On-board Micro USB USBASP for loading HEX file.
13. On-board 16x2 LCD Display Connector.
14. Servo motor Connector (Run only up to 300mA).
15. 12V, 5V and GND bus provided for external peripheral.
16. Four 3mm mounting hole for easy mounting

3. ATMEGA32A Pin Diagram & Features:-

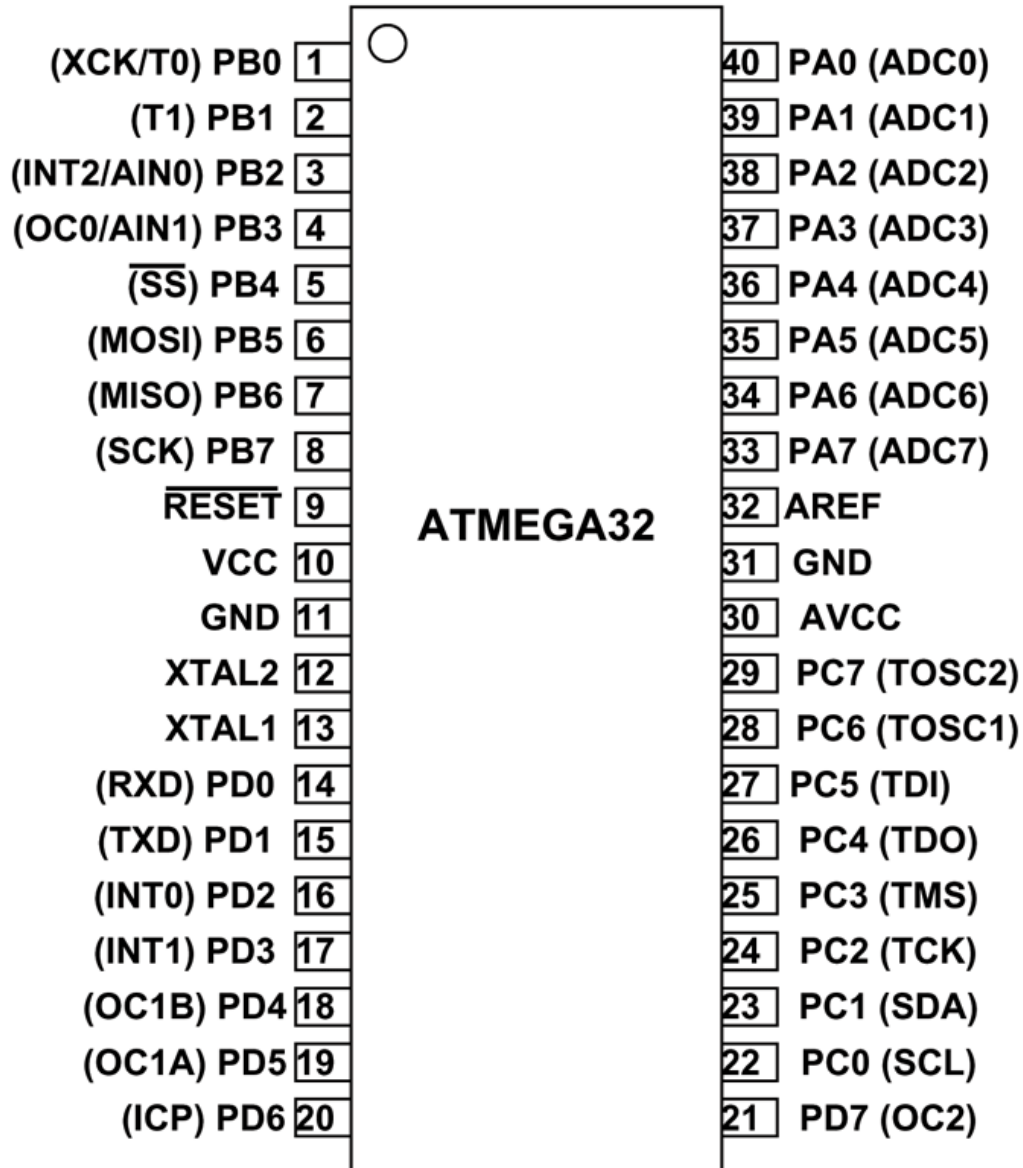

ATmega32 Features :-

- High-performance, Low-power Atmel®AVR® 8-bit Microcontroller
- Advanced RISC Architecture
 - 131 Powerful Instructions – Most Single-clock Cycle Execution
 - 32 × 8 General Purpose Working Registers
 - Fully Static Operation
 - Up to 16 MIPS Throughput at 16MHz
 - On-chip 2-cycle Multiplier
- High Endurance Non-volatile Memory segments
 - 32Kbytes of In-System Self-programmable Flash program memory
 - 1024Bytes EEPROM
 - 2Kbytes Internal SRAM
 - Write/Erase Cycles: 10,000 Flash/100,000 EEPROM
 - Programming Lock for Software Security
- Peripheral Features
 - Two 8-bit Timer/Counters with Separate Presales and Compare Modes
 - One 16-bit Timer/Counter with Separate Prescaler, Compare Mode, and Capture Mode

 - Four PWM Channels
 - 8-channel, 10-bit ADC
 - 8 Single-ended Channels
 - Byte-oriented Two-wire Serial Interface
 - Programmable Serial USART
 - Master/Slave SPI Serial Interface
 - Programmable Watchdog Timer with Separate On-chip Oscillator
 - On-chip Analog Comparator
- Special Microcontroller Features
 - Power-on Reset and Programmable Brown-out Detection
 - Internal Calibrated RC Oscillator
 - External and Internal Interrupt Sources
 - Six Sleep Modes: Idle, ADC Noise Reduction, Power-save, Power-down, Standby and Extended Standby
- I/O and Packages
 - 32 Programmable I/O Lines

4. Product Layout :-

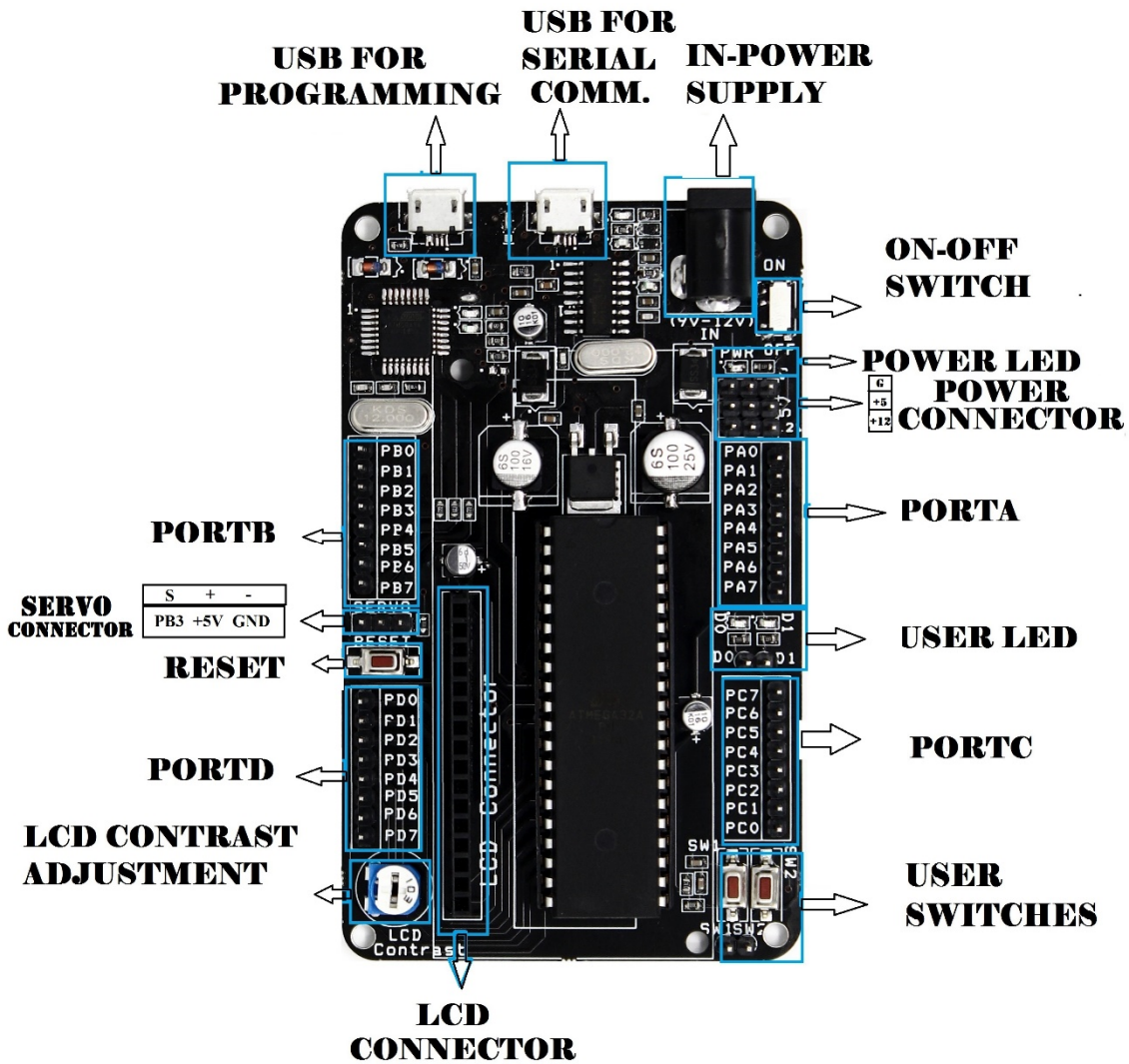

5. RESET AND CRYSTAL CIRCUIT:-

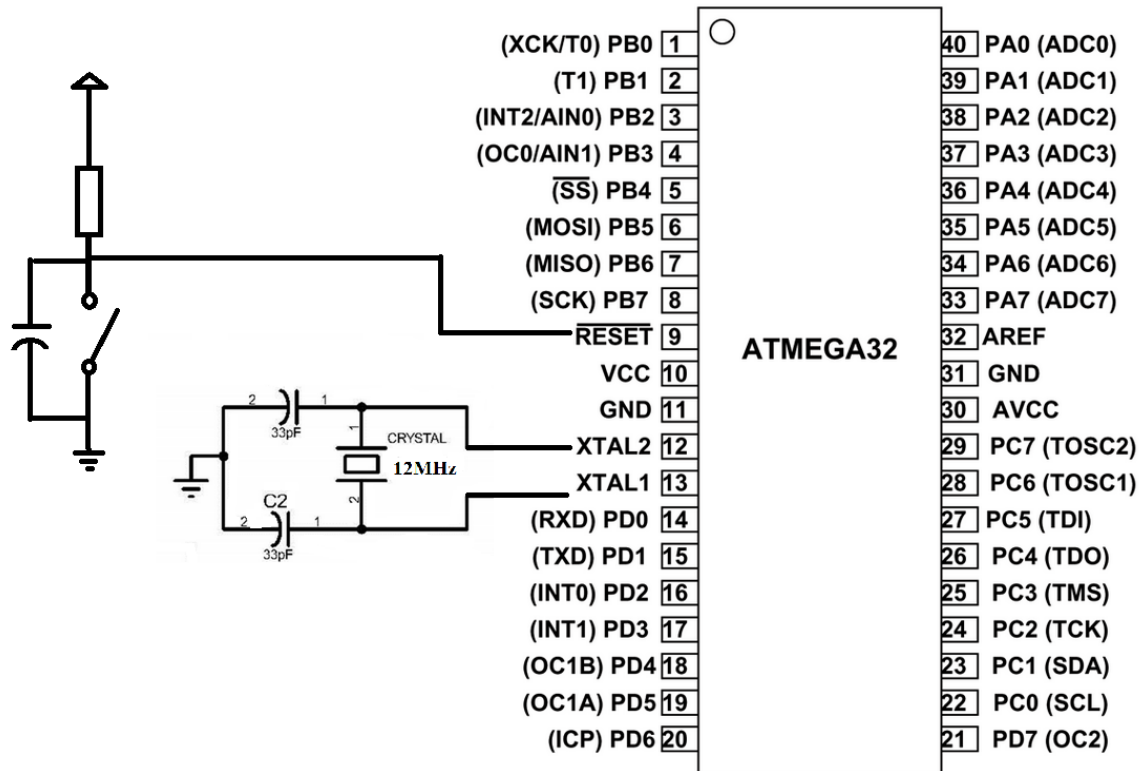

6. Example

A) LED BLINKING

CODE :-

```
#ifndef F_CPU
#define F_CPU 12000000UL           // set the CPU clock
#endif

#include <avr/io.h>
#include <util/delay.h>
#include <stdlib.h>

int main(void)
{
    DDRA=0Xff;

    while(1)
    {
        PORTA = 0xff;
        _delay_ms(500);
        PORTA = 0x00;
        _delay_ms(500);
    }
}
```

SCHEMATIC FOR LED BLINKING

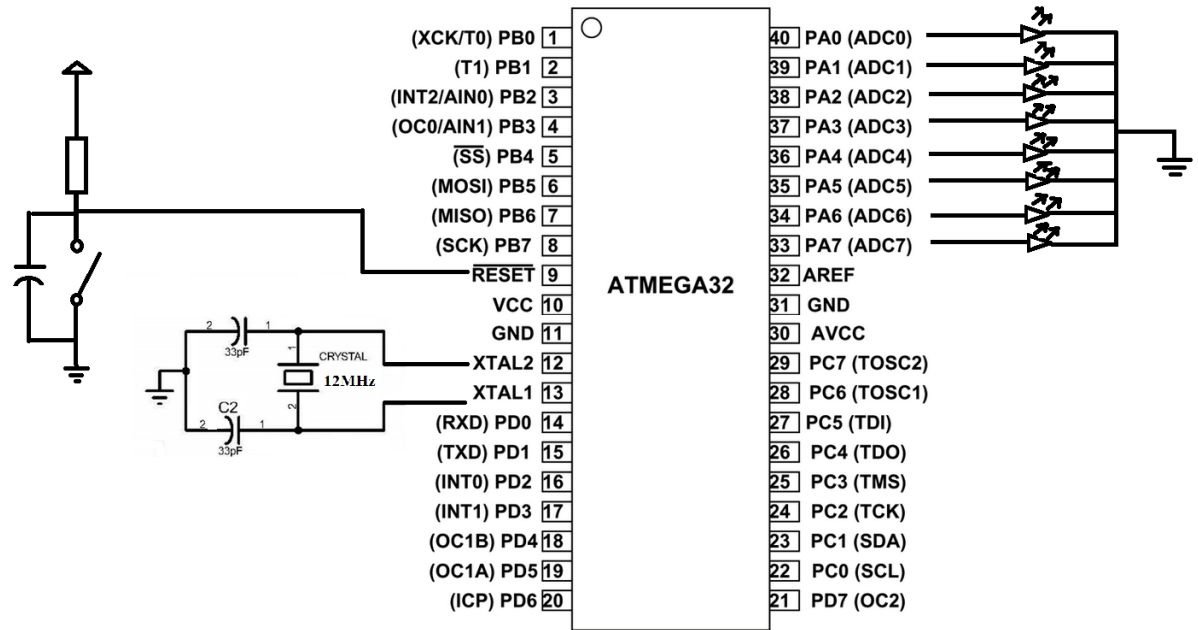

B) LCD DISPLAY :-

(You can find code for LCD interface on Website)

VSS VDD VO RS RW E DO D1 D2 D3 D4 D5 D6 D7 D8 A K

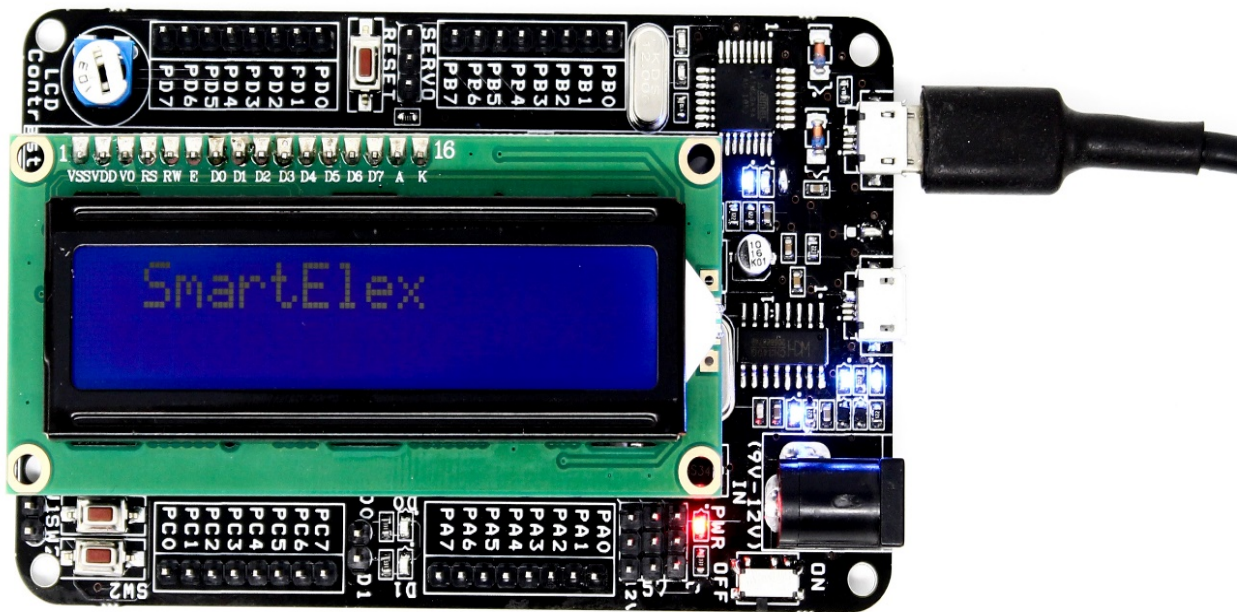
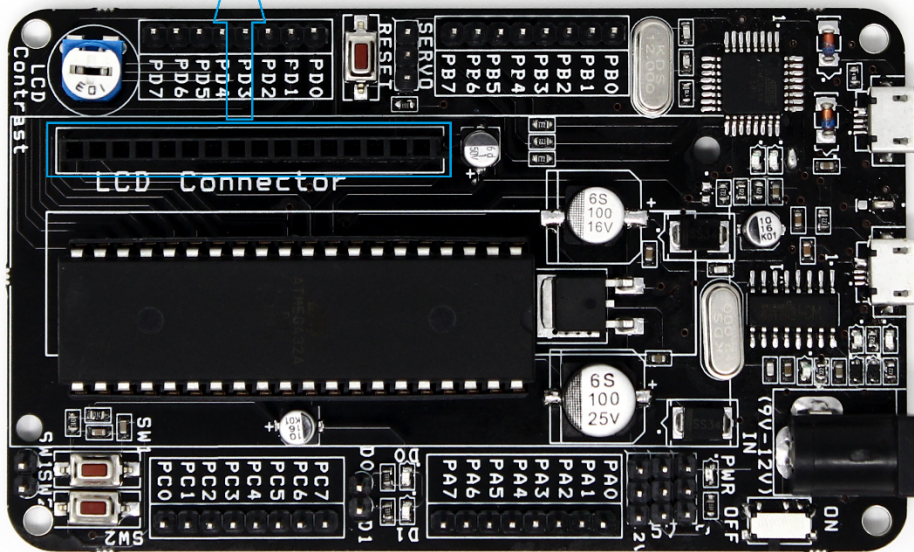

7. Warranty

1. Standard warranty of product is 6 months.
2. Warranty only applies to manufacturing defect.
3. No warranty will apply if the Product has been subject to misuse, static discharge, neglect, accident, modification, or has been soldered or altered in any way.