



## Monolithic Digital Stereo FM Transmitter Radio-Station-on-a-Chip™

**KT0803K**

### ■ Features

**Hardware compatible with KT0803**

**Additional features to KT0803**

**Increased transmission Power**

**Input signal detection**

**Bass boost control**

**32.768 KHz clock support**

**Professional Grade Performance:**

**SNR ≥ 60 dB**

**Stereo Separation > 40 dB**

**International compatible 70MHz ~ 108MHz**

**Ultra-Low Power Consumption:**

**< 17 mA operation current**

**< 3 μA standby current**

**Small Form factor:**

**16-pin SOP**

**Simple Interface:**

**Single power supply**

**Industry standard 2-wire I<sup>2</sup>C MCU**

**interface compatible**

**Advanced Digital Audio Signal Processing:**

**On-chip 20-bit ΔΣ Audio ADC**

**On-chip DSP core**

**On-chip 24dB PGA with optional 1dB step**

**Automatic calibration against process**

**and temperature**

**On-Chip LDO (low-drop-out) regulator:**

**Accommodates 1.6V ~ 3.6V supply**

**Programmable transmit level**

**Programmable pre-emphasis (50/75 μs)**

**Pb-free and RoHS Compliant**

### Applications

**MP3 Player**

**Cellular Phone**

**PDA**

**Portable Personal Media player**

**Laptop Computer**

**Wireless Speaker**

### Rev. 1.1

Information furnished by KT Micro is believed to be accurate and reliable. However, no responsibility is assumed by KT Micro for its use, nor for any infringements of patents or other rights of third parties which may result from its use. No license is granted by implication or otherwise under any patent or patent rights of KT Micro, Inc..

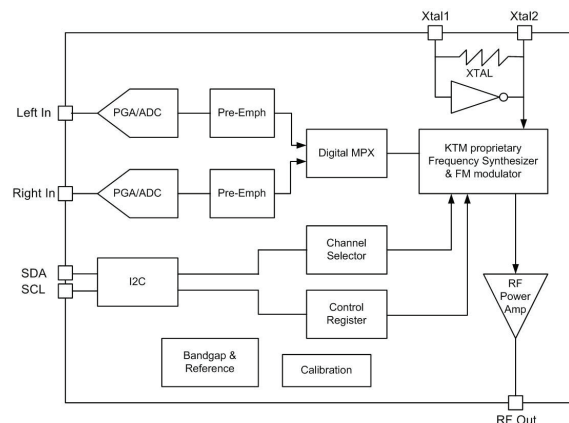

Figure 1: KT0803K System Diagram

### ■ General Description

KT0803K, our new generation of low cost Monolithic Digital FM Transmitter, is designed to process high-fidelity stereo audio signal and transmit modulated FM signal over a short range. It's based on the architecture of award-winning KT0801 and it's also an upgrade of KT0803. The additional features added to KT0803K are increased transmission power up to 113 dBuV, auto level detection and bass boost and support of 32.768K Hz clock or crystal.

The KT0803K features dual 20-bit ΔΣ audio ADCs, a high-fidelity digital stereo audio processor and a fully integrated radio frequency (RF) transmitter. An on-chip low-drop-out regulator (LDO) allows the chip to be integrated in a wide range of low-voltage battery-operated systems with power supply ranging from 1.6V to 3.6V.

The KT0803K is configured as an I<sup>2</sup>C slave and programmed through the industry standard 2-wire MCU interface.

Thanks to its high integration level, the KT0803K is mounted in a generic 16-pin SOP package. It only requires a single low-voltage supply. No external tuning is required that makes design-in effort minimum.

**KT Micro Inc., 22391 Gilberto, Suite D  
Rancho Santa Margarita, CA 92688**

**Tel: 949.713.4000 <http://www.ktmicro.com>**

**Fax: 949.713.4004 Copyright ©2009, KT Micro, Inc..**

## ▪ Operation Condition

**Table 1: Operation Condition**

Parameter	Symbol	Operating Condition	Min	Typ	Max	Units
1.8V Analog Supply <sup>1</sup>	VDD	Relative to GND	1.6	1.8	2.0	V
IO/Regulator Supply	IOVDD	Relative to GND	1.6		3.6	V
Operating Temp	T <sub>A</sub>	Ambient Temperature	0	25	70	°C

Note: 1. No external voltage should be applied to this supply. Decoupling cap should be used instead

## ▪ Specifications and Features

**Table 2: FM Transmitter Functional Parameters** (Unless otherwise noted TA = 0-70 °C, IOVDD=1.6~3.6 V, F<sub>in</sub> = 1 kHz)

Parameter	Symbol	Test/Operating Condition	Min	Nom	Max	Units
FM Frequency Range	F <sub>tx</sub>	Pin 16	76		108	MHz
Current Consumption	I <sub>VDD</sub>	Pin 4 with PA (power amp.) at <b>default power mode (PA_bias = 0, RFGAIN[3:0]=1111)</b>	-	17		mA
Standby Current	I <sub>stand</sub>	Pin 4	-	0.1	1	μA
Signal to Noise Ratio	SNR	V <sub>in</sub> = 0.7 V <sub>D-D</sub> , G <sub>in</sub> = 0	-	60	-	dB
Total Harmonic Distortion	THD	V <sub>in</sub> = 0.7 V <sub>D-D</sub> , G <sub>in</sub> = 0	-	0.3		%
Left/Right Channel Balance	BAL	V <sub>in</sub> = 0.7 V <sub>D-D</sub> , G <sub>in</sub> = 0	-0.2	-	0.2	dB
Stereo Separation (Left<->Right)	SEP	V <sub>in</sub> = 0.7 V <sub>D-D</sub> , G <sub>in</sub> = 0		40	-	dB
Sub Carrier Rejection Ratio	SCR	V <sub>in</sub> = 0.7 V <sub>D-D</sub> , G <sub>in</sub> = 0	-	-	60	dB
Input Swing <sup>1</sup>	V <sub>in</sub>	Single-ended input	-	0.35	1.4	V <sub>RMS</sub>
PGA Range for Audio Input	G <sub>in</sub>		-12	0	12	dB
PGA Gain Step for Audio Input	G <sub>step</sub>		1		4	dB
Required Input Common-Mode Voltage when DC-coupled	V <sub>cm</sub>	Pin 5, 7	0	0.8	1.8	V
Power Supply Rejection <sup>2</sup>	PSRR	IOVDD = 1.9 ~ 3.6 V	40	-	-	dB
Ground Bounce Rejection <sup>2</sup>	GSRR	IOVDD = 1.9 ~ 3.6 V	40	-	-	dB
Input Resistance (Audio Input)	R <sub>in</sub>	Pin 5, 7	120	150	180	kΩ
Input Capacitance (Audio Input)	C <sub>in</sub>	Pin 5, 7	0.5	0.8	1.2	pF
Audio Input Frequency Band	F <sub>in</sub>	Pin 5, 7	20	-	15k	Hz
Transmit Level	V <sub>out</sub>		96	103	113	dBμV
Channel Step	STEP		-	50		kHz
Pilot Deviation				7.5	15	kHz
Audio Deviation			75		150	kHz
Frequency Response		Mono, -3dB, ΔF=60kHz, 50/75μs pre-emphasis	30		15k	Hz
Pre-emphasis Time Constant	T <sub>pre</sub>	SIG PROC<1> = 1	-	50	-	μs
		SIG PROC<0> = 0	-	75	-	μs
Crystal/External Clock	CLK	Input clock		32.768		KHz
2-wire I <sup>2</sup> C Clock	SCL	Pin 14	0	100	400	kHz
High Level Input Voltage	V <sub>IH</sub>	Pin 4, 8, 12, 14, 16	0.75 x IOVDD	-	IOVDD + 0.25	V
Low Level Input Voltage	V <sub>IL</sub>	Pin 4, 8, 12, 14, 16	- 0.25	-	0.25 x IOVDD	V



Notes:

1. Maximum is given on the condition of PGA gain = -12dB.
2. Fin = 20 ~ 15k Hz.

▪ **Package and Pin List**

**Table 3: KT0803K Pin Definition**

Pin Index	Name	I/O Type	Function
2	XI	Analog I/O	Crystal input.
3	XO	Analog I/O	Crystal input
4	IOVDD	Power	1.6~3.3V external logic IOVDD
1, 5,11,15	GND	Ground	Can be shorted together and connected to ground
6	INL	Analog Input	Left channel audio input.
7	INR	Analog Input	Right channel audio input.
8	SW	Digital Input	Control bit. Chip enable, supply mode
9, 12	GND	Ground	Ground
10	RSTB	Digital Input	Reset (active low).
13	SDA	Digital I/O	Serial data I/O.
14	SCL	Digital I/O	Serial clock input.
16	PA_OUT	Analog Output	FM RF output.

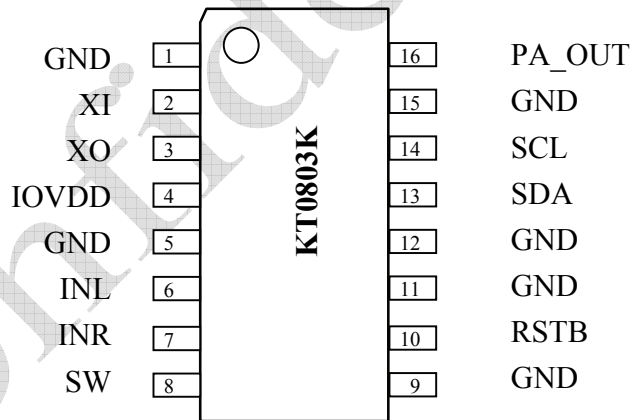

**Figure 2: KT0803K Pin-out**

## I<sup>2</sup>C Compatible 2-Wire Serial Interface

### General Descriptions

The serial interface consists of a serial controller and registers. An internal address decoder transfers the content of the data into appropriate registers. **Please note that the I2C address is 0x 0111110 the same as in KT0803. Neither software nor hardware change is needed if KT0803K is used to replace KT0803.**

Both the write and read operations are supported according to the following protocol:

#### Write Operations:

##### BYTE WRITE:

The write operation is accomplished via a 3-byte sequence:

- Serial address with write command
- Register address
- Register data

A write operation requires an 8-bit register address following the device address word and acknowledgment. Upon receipt of this address, the KT0803K will again respond with a "0" and then clock in the 8-bit register data. Following receipt of the 8-bit register data, the KT0803K will output a "0" and the addressing device, such as a microcontroller, must terminate the write sequence with a stop condition (see Figure 3).

#### Read Operations:

##### RANDOM READ:

The read operation is accomplished via a 4-byte sequence:

- Serial address with write command
- Register address
- Serial address with read command
- Register data

Once the device address and register address are clocked in and acknowledged by the KT0803K, the microcontroller must generate another start condition. The microcontroller now initiates a current address read by sending a device address with the read/write select bit high. The KT0803K acknowledges the device address and serially clocks out the register data. The microcontroller does not respond with a "0" but does generate a following stop condition (see Figure 3).

#### RANDOM REGISTER WRITE PROCEDURE

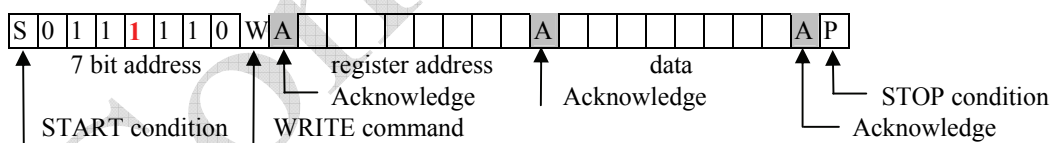

#### RANDOM REGISTER READ PROCEDURE

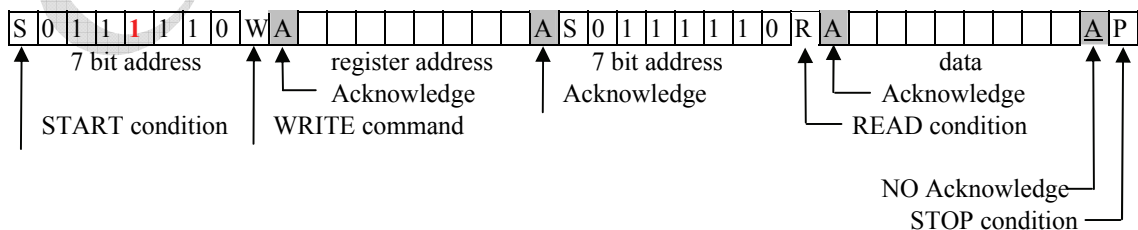

**Figure 3: Serial Interface Protocol**

**CURRENT ADDRESS READ:** The internal data register address counter maintains the last address

accessed during the last read or write operation, incremented by one. This address stays valid between operations as long as the chip power is maintained.

Once the device address with the read/write select bit set to “1” is clocked in and acknowledged by the KT0803K, the current address data word is serially clocked out. The microcontroller does not respond with an input “0” but does generate a following stop condition (see Figure 4).

#### CURRENT REGISTER READ PROCEDURE

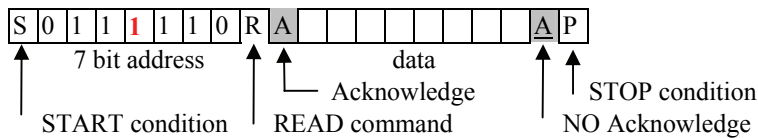

**Figure 4: Serial Interface Protocol**

**Note:** The serial controller supports slave mode only. Any register can be addressed randomly.

The address of the slave in the first 7 bits and the 8th bit tells whether the master is receiving data from the slave or transmitting data to the slave. The I<sup>2</sup>C write address is 0x7C and the read address is 0x7D.

### Slave Mode Protocol

With reference to the clocking scheme shown in Figure 5, the serial interface operates in the following manner:



**Figure 5: Serial Interface Slave Mode Protocol**

**CLOCK and DATA TRANSITIONS:** The SDA pin is normally pulled high with an external device. Data on the SDA pin may change only during SCL low time periods (see Figure 6). Data changes during SCL high periods will indicate a start or stop condition as defined below.

**START CONDITION:** A high-to-low transition of SDA with SCL high is a start condition which must precede any other command (see Figure 7).

**STOP CONDITION:** A low-to-high transition of SDA with SCL high is a stop condition. After a read sequence, the stop command will place the KT0803K in a standby power mode (see Figure 7).

**ACKNOWLEDGE:** All addresses and data words are serially transmitted to and from the KT0803K in 8-bit words. The KT0803K sends a “0” to acknowledge that it has received each word. This happens during the ninth clock cycle (see Figure 8).



Data Validity

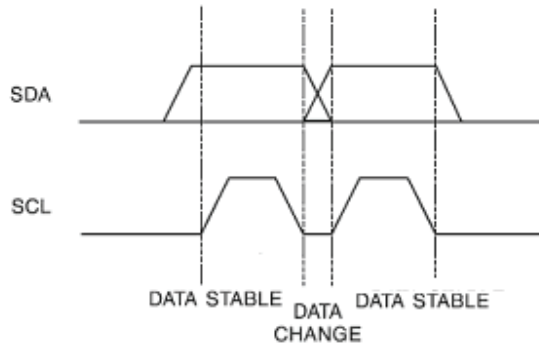

**Figure 6: Clock and Data Transitions**

Start and Stop Definition

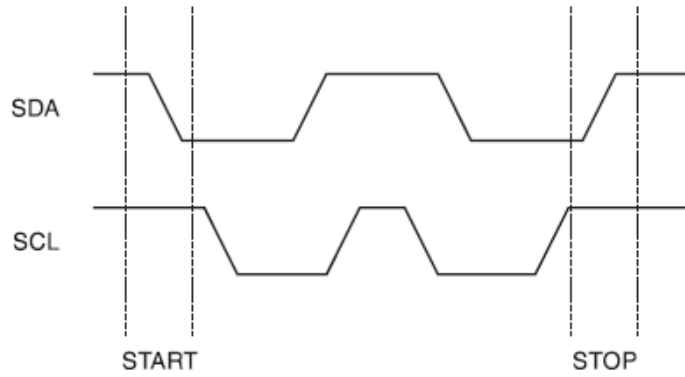

**Figure 7: Start and Stop Definition**

Output Acknowledge

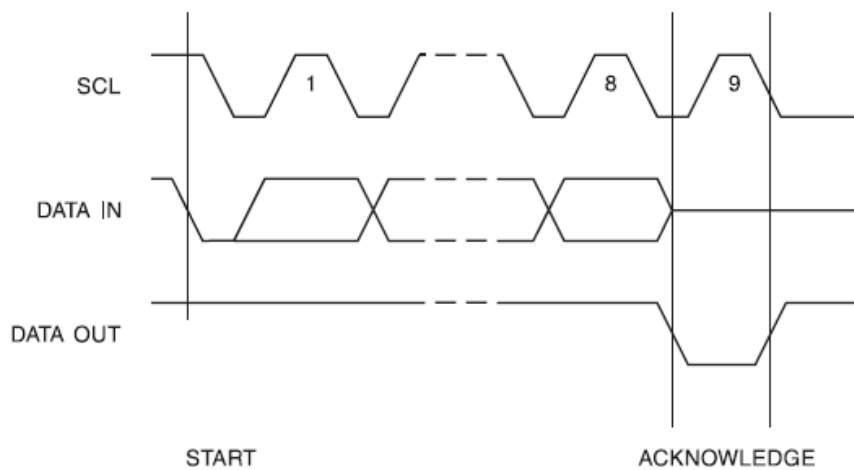

**Figure 8: Acknowledge**

## Register Bank

The register bank stores channel frequency codes, calibration parameters, operation status, mode and power controls, which can be accessed by the internal digital controller, state machines and external micro controllers through the serial interface.

All registers are 8 bits wide. Control logics are active high unless specifically noted.

Register	7	6	5	4	3	2	1	0
0x00	CHSEL[8:1]							
0x01	RFGAIN[1:0]		PGA[2:0]			CHSEL[11:9]		
0x02	CHSEL[0]	RFGAIN[3]	-	-	MUTE	PLTADJ	-	PHTCNST
0x04	MONO		PGA_LSB[1:0]		FDEV[1:0]		BASS[1:0]	
0x0B	-	-	PDPA	-	-	-	-	-
0x0E	-	-	-	-	-	-	PA_BIAS	-
0x0F	-	-	-	PW_OK	-	SLNCID	-	-
0x10	-	-	-	LMTLVL[1:0]		-	-	PGAMOD
0x12	SLNCDIS	SLNCTHL[2:0]			SLNCTHH[2:0]		-	SW_MOD
0x13	RFGAIN[2]	-	-	-	-	PA_CTRL	-	-
0x14	SLNCTIME[2:0]			SLNCCNTHIGH[2:0]			-	-
0x16	-		-	-	-	SLNCCNTLOW[2:0]		

Note 1: ONLY read/write the defined registers.

Note 2: Shaded registers are used in KT0803.

### Register 0x00 (Address: 0x00, Default value: 0x81)

Bit	7	6	5	4	3	2	1	0
KT0803K	CHSEL[8:1]							
KT0803	CHSEL[7:0]							

As the minimum frequency step is changed from 100KHz in KT0803 to 50KHz in KT0803K. The 12 bits (Reg0x1[2:0]; Reg0x0[7:0]; Reg0x2[7]) are required to select the FM transmission channel instead of 11 bits in KT0803. If a 100 KHz step is wanted, set Reg0x2[7] to 0 and thus no software change is needed from KT0803 to KT0803K to set the same FM frequency.

### Register 0x01 (Address: 0x01, Default value: 0xC3)

Bit	7	6	5	4	3	2	1	0
KT0803K	RFGAIN[1:0]		PGA[2:0]			CHSEL[11:9]		
KT0803	RFGAIN[1:0]		PGA[2:0]			CHSEL[10:8]		

Bits	Type	Default	Label	Description
7:6	RW	11	RFGAIN[1:0]	Transmission Range Adjustment with RFGAIN[3] in Reg 0x02[6] and RFGAIN[2] in Reg 0x13[7] (See Table 4 below)
5:3	RW	000	PGA[2:0]	PGA Gain Control (see PGA_LSB description, Reg 0x04) 111: 12dB 110: 8dB 101: 4dB 100: 0dB 000: 0dB 001: -4dB 010: -8dB 011: -12dB
2:0	RW	011	CHSEL[11:9]	FM Channel Selection[11:9]

**Table 4: Transmission power setting**

RFGAIN<3:0>	RFOUT
0000	95.5 dBuV
0001	96.5 dBuV
0010	97.5 dBuV
0011	98.2 dBuV
0100	98.9 dBuV
0101	100 dBuV
0110	101.5 dBuV
0111	102.8 dBuV
1000	105.1 dBuV (107.2dBuV PA_BIAS=1)
1001	105.6 dBuV (108dBuV, PA_BIAS=1)
1010	106.2 dBuV (108.7dBuV, PA_BIAS=1)
1011	106.5 dBuV (109.5dBuV, PA_BIAS=1)
1100	107 dBuV (110.3dBuV, PA_BIAS=1)
1101	107.4 dBuV (111dBuV, PA_BIAS=1)
1110	107.7 dBuV (111.7dBuV, PA_BIAS=1)
<b>1111 (default setting)</b>	<b>108 dBuV (112.5dBuV, PA_BIAS=1)</b>

**Register 0x02 (Address: 0x02, Default: 0x40)**

Bit	7	6	5	4	3	2	1	0
KT0803K	CHSEL[0]	RFGAIN[3]	-	-	MUTE	PLTADJ	-	PHTCNST
KT0803	-	-	-	-	MUTE	PLTADJ	-	PHTCNST

Bits	Type	Default	Label	Description
7	RW	0	CHSEL[0]	LSB o CHSEL, additional to KT0803
6	RW	1	RFGAIN[3]	MSB of RFGAIN
5:4	RW	00	Reserved	
3	RW	0	MUTE	Software Mute 1: MUTE Enabled 0: MUTE Disabled
2	RW	0	PLTADJ	Pilot Tone Amplitude Adjustment 1: Amplitude high 0: Amplitude low
1	RW	0	NA	Reserved
0	RW	0	PHTCNST	Pre-emphasis Time-Constant Set 1: 50 $\mu$ s (Europe, Australia) 0: 75 $\mu$ s (USA, Japan)

**Register 0x04 (Address: 0x04, Default: 0x04) - New**

Bit	7	6	5	4	3	2	1	0
KT0803K	-	MONO	PGA_LSB[1:0]		FDEV[1:0]		BASS[1:0]	
KT0803	-	-	-		-		-	

Bits	Type	Default	Label	Description
7	RW	0	Reserved	
6	RW	0	MONO	Force MONO





Bits	Type	Default	Label	Description																																																																																																			
5:4	RW	00	PGA_LSB[1:0]	<table border="1"> <thead> <tr> <th>PGA&lt;2:0&gt;</th> <th>PGA_LSB&lt;1:0&gt;</th> <th>PGA Gain</th> </tr> </thead> <tbody> <tr><td><b>111</b></td><td><b>11</b></td><td><b>12dB</b></td></tr> <tr><td>111</td><td>10</td><td>11</td></tr> <tr><td>111</td><td>01</td><td>10</td></tr> <tr><td>111</td><td>00</td><td>9</td></tr> <tr><td><b>110</b></td><td><b>11</b></td><td><b>8</b></td></tr> <tr><td>110</td><td>10</td><td>7</td></tr> <tr><td>110</td><td>01</td><td>6</td></tr> <tr><td>110</td><td>00</td><td>5</td></tr> <tr><td><b>101</b></td><td><b>11</b></td><td><b>4</b></td></tr> <tr><td>101</td><td>10</td><td>3</td></tr> <tr><td>101</td><td>01</td><td>2</td></tr> <tr><td>101</td><td>00</td><td>1</td></tr> <tr><td><b>100</b></td><td><b>11</b></td><td><b>0</b></td></tr> <tr><td>100</td><td>10</td><td>0</td></tr> <tr><td>100</td><td>01</td><td>0</td></tr> <tr><td>100</td><td>00</td><td>0</td></tr> <tr><td><b>000</b></td><td><b>00</b></td><td><b>0</b></td></tr> <tr><td>000</td><td>01</td><td>-1</td></tr> <tr><td>000</td><td>10</td><td>-2</td></tr> <tr><td>000</td><td>11</td><td>-3</td></tr> <tr><td><b>001</b></td><td><b>00</b></td><td><b>-4</b></td></tr> <tr><td>001</td><td>01</td><td>-5</td></tr> <tr><td>001</td><td>10</td><td>-6</td></tr> <tr><td>001</td><td>11</td><td>-7</td></tr> <tr><td><b>010</b></td><td><b>00</b></td><td><b>-8</b></td></tr> <tr><td>010</td><td>01</td><td>-9</td></tr> <tr><td>010</td><td>10</td><td>-10</td></tr> <tr><td>010</td><td>11</td><td>-11</td></tr> <tr><td><b>011</b></td><td><b>00</b></td><td><b>-12</b></td></tr> <tr><td>011</td><td>01</td><td>-13</td></tr> <tr><td>011</td><td>10</td><td>-14</td></tr> <tr><td>011</td><td>11</td><td>-15</td></tr> </tbody> </table>	PGA<2:0>	PGA_LSB<1:0>	PGA Gain	<b>111</b>	<b>11</b>	<b>12dB</b>	111	10	11	111	01	10	111	00	9	<b>110</b>	<b>11</b>	<b>8</b>	110	10	7	110	01	6	110	00	5	<b>101</b>	<b>11</b>	<b>4</b>	101	10	3	101	01	2	101	00	1	<b>100</b>	<b>11</b>	<b>0</b>	100	10	0	100	01	0	100	00	0	<b>000</b>	<b>00</b>	<b>0</b>	000	01	-1	000	10	-2	000	11	-3	<b>001</b>	<b>00</b>	<b>-4</b>	001	01	-5	001	10	-6	001	11	-7	<b>010</b>	<b>00</b>	<b>-8</b>	010	01	-9	010	10	-10	010	11	-11	<b>011</b>	<b>00</b>	<b>-12</b>	011	01	-13	011	10	-14	011	11	-15
				PGA<2:0>	PGA_LSB<1:0>	PGA Gain																																																																																																	
				<b>111</b>	<b>11</b>	<b>12dB</b>																																																																																																	
				111	10	11																																																																																																	
				111	01	10																																																																																																	
				111	00	9																																																																																																	
				<b>110</b>	<b>11</b>	<b>8</b>																																																																																																	
				110	10	7																																																																																																	
				110	01	6																																																																																																	
				110	00	5																																																																																																	
				<b>101</b>	<b>11</b>	<b>4</b>																																																																																																	
				101	10	3																																																																																																	
				101	01	2																																																																																																	
				101	00	1																																																																																																	
				<b>100</b>	<b>11</b>	<b>0</b>																																																																																																	
				100	10	0																																																																																																	
				100	01	0																																																																																																	
				100	00	0																																																																																																	
				<b>000</b>	<b>00</b>	<b>0</b>																																																																																																	
				000	01	-1																																																																																																	
				000	10	-2																																																																																																	
000	11	-3																																																																																																					
<b>001</b>	<b>00</b>	<b>-4</b>																																																																																																					
001	01	-5																																																																																																					
001	10	-6																																																																																																					
001	11	-7																																																																																																					
<b>010</b>	<b>00</b>	<b>-8</b>																																																																																																					
010	01	-9																																																																																																					
010	10	-10																																																																																																					
010	11	-11																																																																																																					
<b>011</b>	<b>00</b>	<b>-12</b>																																																																																																					
011	01	-13																																																																																																					
011	10	-14																																																																																																					
011	11	-15																																																																																																					
3:2	RW	01	FDEV[1:0]	Frequency deviation adjustment 00 : 75kHz 01 : 112.5kHz 10 : 150kHz 11 : 187.5kHz																																																																																																			
1:0	RW	00	BASS[1:0]	Bass boost control 00 : Disabled 01 : 5dB 10 : 11dB 11 : 17dB																																																																																																			

**Register 0x0B (Address: 0x0B, Default: 0x00) - New**

Bit	7	6	5	4	3	2	1	0
KT0803K	-	-	PDPA	-	-	-	-	-
KT0803	-	-	-	-	-	-	-	-

Bits	Type	Default	Label	Description
7	RW	0	Reserved	



Bits	Type	Default	Label	Description
6	RW	0	Reserved	Power Amplifier Power Down
5	RW	0	PDPA	
4	RW	0	Reserved	
3	RW	0	Reserved	
1	RW	0	Reserved	
0	RW	0	Reserved	

**Register 0x0E (Address: 0x0E, Default: 0x02) – New**

Bit	7	6	5	4	3	2	1	0
KT0803K	-	-	-	-	-	-	PA_BIAS	-
KT0803	-	-	-	-	-	-	-	-

Bits	Type	Default	Label	Description
7:2	RW	0x00	Reserved	PA bias current enhancement.
1	RW	1	PA_BIAS	
0	RW	0	Reserved	

**Register 0x0F (Address: 0x0F, Read only) – New**

Bit	7	6	5	4	3	2	1	0
KT0803K	-	-	-	PW_OK	-	SLNCID	-	-
KT0803	-	-	-	-	-	-	-	-

Bits	Type	Default	Label	Description
7	R	NA	Reserved	Power OK indicator 1 when Silence is detected
6	R	NA	Reserved	
5	R	NA	Reserved	
4	R	NA	PW_OK	
3	R	NA	Reserved	
2	R	NA	SLNCID	
1	R	NA	Reserved	
0	R	NA	Reserved	

**Register 0x10 (Address: 0x10, Default: 0x08) – New**

Bit	7	6	5	4	3	2	1	0
KT0803K	-	-	-	LMTLVL[1:0]		-	-	PGAMOD
KT0803	-	-	-	-	-	-	-	-

Bits	Type	Default	Label	Description
7:5	RW	000	Reserved	Internal audio limiter level control 00 = 0.6875 01 = 0.75 10 = 0.875 11 = 0.9625
4:3	RW	01	LMTLVL[1:0]	
2:1	RW	00	Reserved	
0	RW	0	PGAMOD	
				PGA mode selection 0 = 4dB step (compatible with KT0803) 1 = 1dB step with PGA_LSB[1:0] used

**Register 0x12 (Address: 0x12, Default: 0x80) - New**

Bit	7	6	5	4	3	2	1	0
KT0803K	SLNCDIS		SLNCTHL[2:0]			SLNCTHH[2:0]		SW_MOD
KT0803	-	-	-	-	-	-	-	-

Bits	Type	Default	Label	Description
7	RW	1	SLNCDIS	Silence detection disable 0 : enable 1 : disable
6:4	RW	000	SLNCTHL	Silence detection low threshold 000 : 0.25mv 001 : 0.5mv 010 : 1mv 011 : 2mv 100 : 4mv 101 : 8mv 110 : 16mv 111 : 32mv
3:1	RW	000	SLNCTHH	Silence detection high threshold 000 : 0.5mv 001 : 1mv 010 : 2mv 011 : 4mv 100 : 8mv 101 : 16mv 110 : 32mv 111 : 64mv
0	RW	0	SW_MOD	Switching channel mode selection. 0 = mute when changing channel 1 = pa off when changing channel

**Register 0x13 (Address: 0x13, Default: 0x80)**

Bit	7	6	5	4	3	2	1	0
KT0803K	RFGAIN[2]	-			-	PA_CTRL	-	-
KT0803	PA_HI_PW	-	-	-	-	-	-	-

Bits	Type	Default	Label	Description
7	RW	1	RFGAIN[2]	PA (Power amplifier) power (combined with Reg 0x01[7:6] and Reg 0x02[6])to set up transmission range)
6:3	RW	0000	Reserved	<b>Power amplifier structure selection</b> 0 = Internal power supply, KT0803 compatible 1 = External power supply via external inductor <b>Note : When an external inductor is used, this bit must be set to 1 immediately after the Power OK indicator Reg 0x0F[4] is set to 1. Otherwise, the device may be destroyed!</b>
2	RW	0	PA_CTRL	
1:0	RW	00	Reserved	

**Register 0x14 (Address: 0x14, default 0x00) - New**

Bit	7	6	5	4	3	2	1	0
KT0803K	SLNCTIME<2:0>			SLNCCNTHIGH<2:0>			-	-
KT0803	-	-	-	-	-	-	-	-

Bits	Type	Default	Label	Description
7:5	RW	000	SLNCTIME<2:0>	Silence detection low level and high level duration time 000 : 50ms 001 : 100ms 010 : 200ms 011 : 400ms 100 : 1s 101 : 2s 110 : 4s 111 : 8s
4:2	RW	000	SLNCCNTHIGH<2:0>	Silence detection high level counter threshold 000 : 15 001 : 31 010 : 63 011 : 127 100 : 255 101 : 511 110 : 1023 111 : 2047
1: 0	RW	00	Reserved	

**Register 0x16 (Address 0x16, default: 0x00) - New**

Bit	7	6	5	4	3	2	1	0
KT0803K	-			-	-	SLNCCNTLOW[2:0]		
KT0803	-	-	-	-	-	-	-	-

Bits	Type	Default	Label	Description
7:3	RW	0x0	Reserved	
2:0	RW	000	SLNCCNTLOW[2:0]	Silence low counter 000 : 1 001 : 2 010 : 4 011 : 8 100 : 16 101 : 32 110 : 64 111 : 128

## Chip Enable and Mode Control

There is one external pin SW (Pin 8) to enable the chip. The definition is shown below.

**Table 5: Pin SW**

Input SW	Chip Mode	IOVDD	Clock Source
0	Power off	N/A	N/A
1	Power On	1.6~3.6V	External crystal or clock

## Mute

The FM transmitter can be muted by setting Register MUTE to “1” through I2C programming.

## Silence Detection

Bit name	Register location	Description
SLNCDIS	Reg 0x12[7]	Setting to 0 to enable the silence detection
SLNCTIME[2:0]	Reg 0x14[7:5]	silence detection time window
SLNCTHL[2:0]	Reg 0x12[6:4]	Low threshold voltage of input signal for silence detection
SLNCTHH[2:0]	Reg 0x12[3:1]	High threshold voltage of input signal for silence detection
SLNCCNTTHL[2:0]	Reg 0x14[4:2]	# of time when the input signal amplitude is lower than SLNCTHL
SLNCCNTTHH[2:0]	Reg 0x16[2:1]	# of time when the input signal amplitude is higher than SLNCTHH
SLNCID	Reg 0x0F[2]	(Read only) Set to 1 when silence is detected.

The silence detection scheme is enabled by setting SLNCDIS to 0.

During the time defined by SLNCTIME[2:0], the chip will be muted when the number of time when the input amplitude is higher than the voltage defined by SLNCTHL[2:0] is lower than SLNCCNTTHL[2:0]. The SLNCID bit is set to 0.

When the input signal amplitude is higher than the voltage defined by SLNCTHH[2:0] and the number of time when that happens is more than SLNCCNTTHH[2:0], the chip exits from the mute status and the SLNCID is cleared to 0.

## Reset

The global reset is issued after the RSTB pin set to “0” or automatic on-chip power-on reset. After a global reset, all registers are reset to the default value.

### ▪ Typical Application Circuits

The KT0803K can be integrated in a wide range of systems by requiring only a single power supply. Figure 9 shows the external diagram for the drop-in replacement of KT0803.

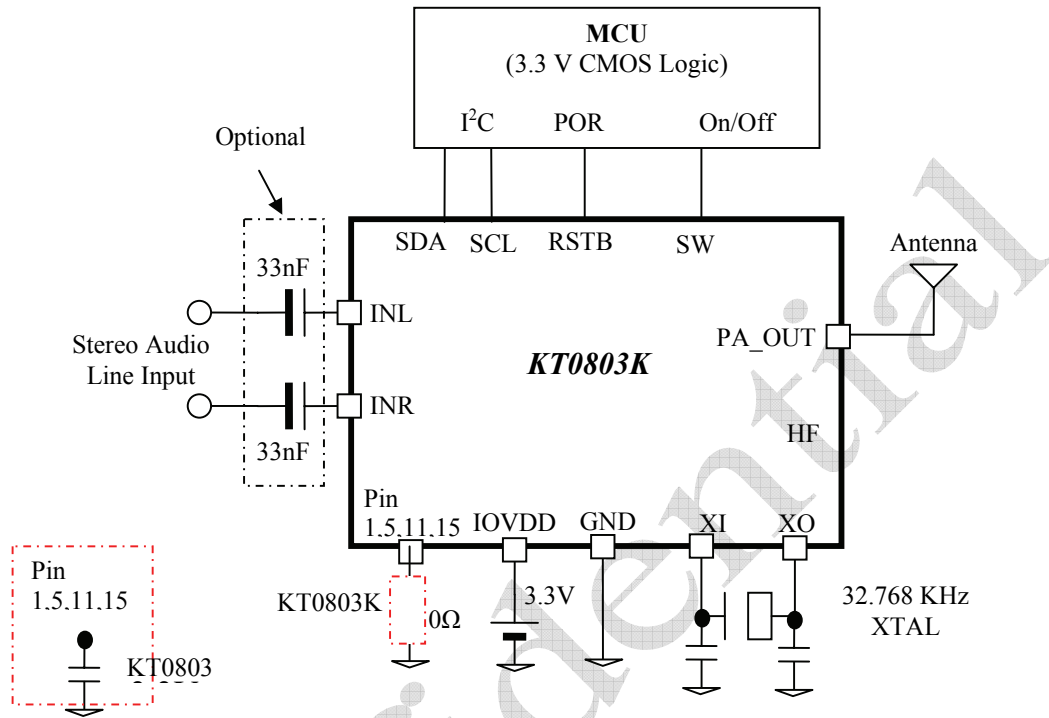

**Figure 9: Typical configuration for a drop-in replacement**

As shown in the red block above, Pin 1, 5, 11 and 15 are VDD pins in KT0803 that are required to be connected to a decoupling capacitor. These four pins are GND pins in KT0803K. Customers can replace the decoupling capacitor of a 0-ohm resistor without PCB board change.

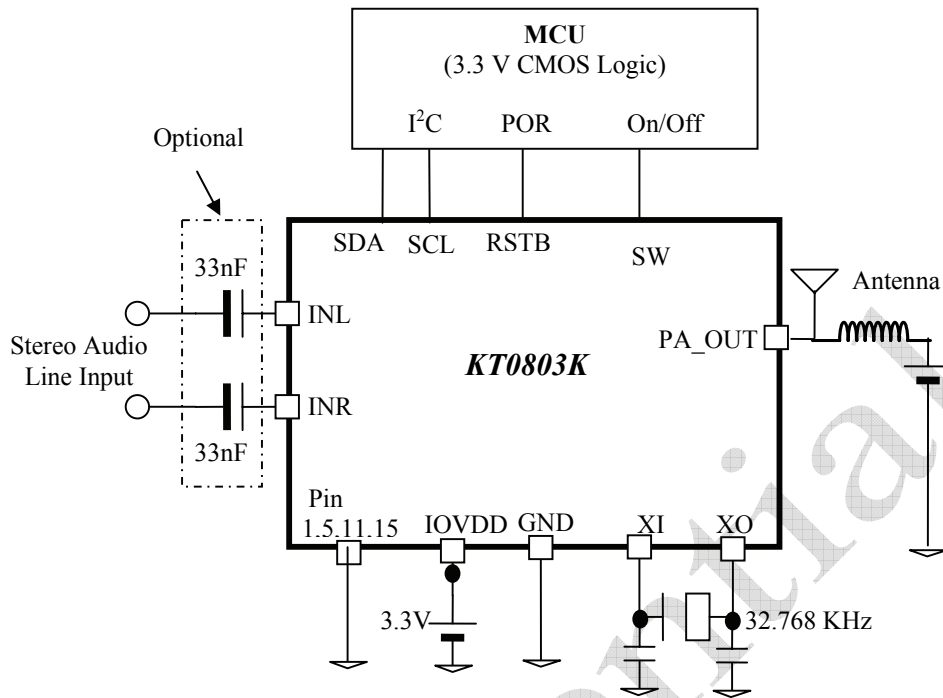
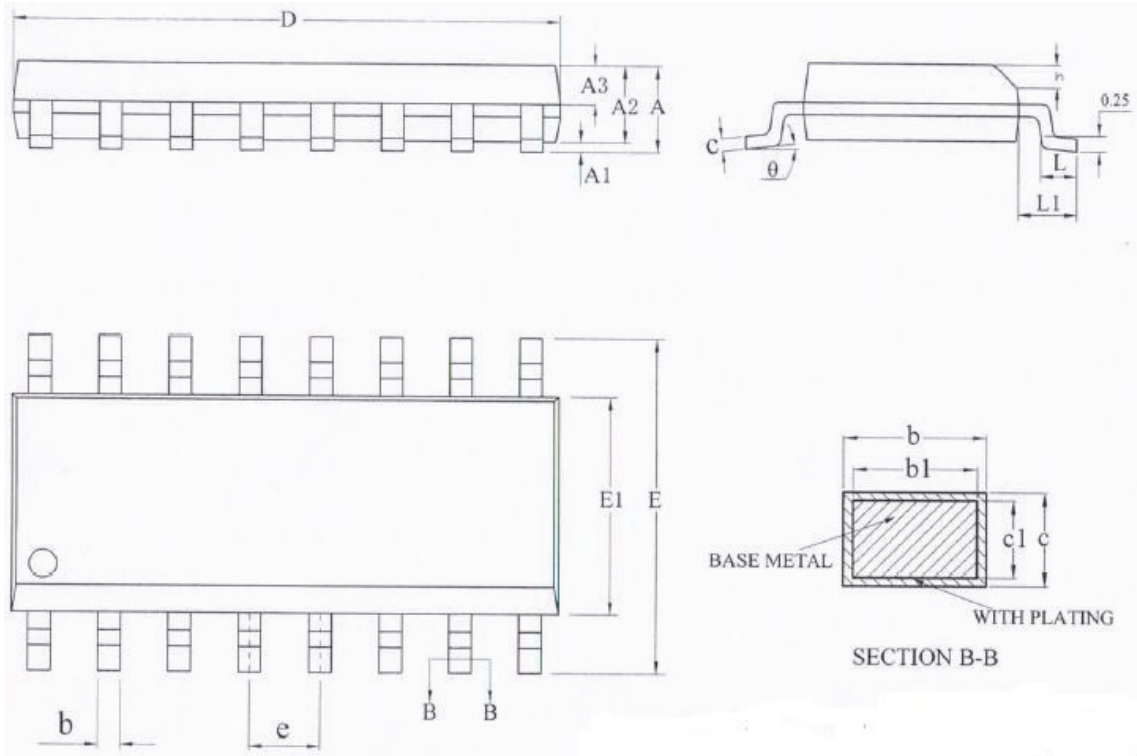

Figure 10: Application that requires higher transmission power (>5dBm)



▪ **Package Outline**



Symbols	(MILLIMETERS)			Symbols	(MILLIMETERS)		
	MIN	NOM	MAX		MIN	NOM	MAX
A			1.75	D	9.70	9.90	10.10
A1	0.10		0.25	E	5.80	6.00	6.20
A2	1.30	1.40	1.50	E1	3.70	3.90	4.10
A3	0.60	0.65	0.70	e		1.27BSC	
b	0.39		0.48	h	0.25		0.50
b1	0.38	0.41	0.43	L	0.50		0.80
c	0.21		0.26	L1		1.05BSC	
C1	0.19	0.20	0.21	θ	0		8°





▪ **Revision History**

V1.0	Official Release
V1.1	I2C addresses in text

Confidential



▪ **Contact Information**

**KT Micro Inc.**

22391 Gilberto, Suite D  
Rancho Santa Margarita, CA 92688  
USA  
Tel: 949-713-4000  
Fax: 949-713-4004  
Email: [sales@ktmicro.com](mailto:sales@ktmicro.com)

**北京昆腾微电子有限公司**

北京市海淀区蓝靛厂东路 2 号金源时代商务中心  
2 号楼 B 座 8 层 (100089)  
电话: 8610-88891945  
传真: 8610-88891977  
电子邮件: [sales@ktmicro.com](mailto:sales@ktmicro.com)  
网站: <http://www.ktmicro.com.cn>

Confidential